

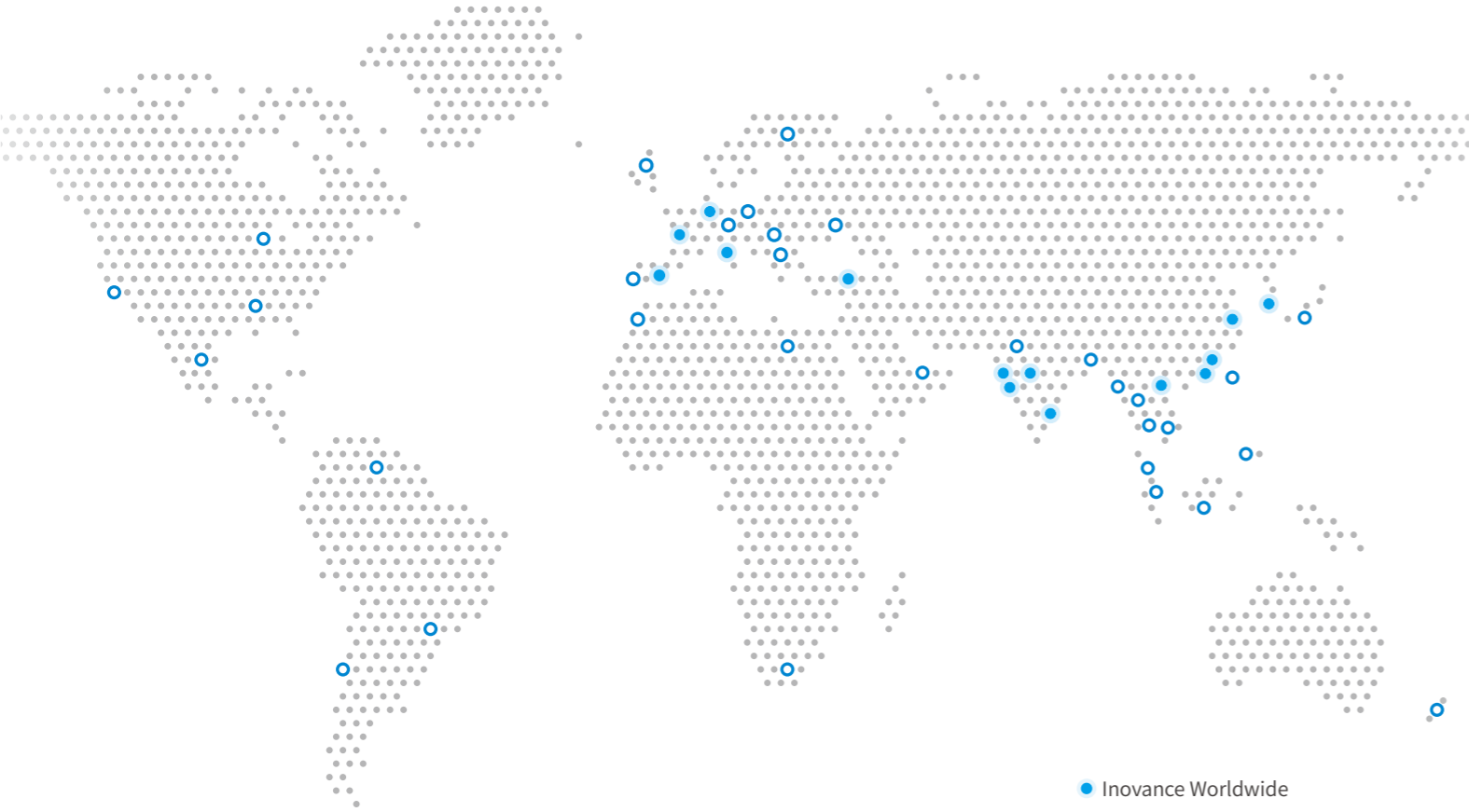

19120627 A00

Copyright © Shenzhen Inovance Technology Co., Ltd.



- Inovance Worldwide
- Distribution & Service Partners

Advancing industrial technology, for a better world

Europe

- **Germany-Stuttgart**
☎ +49 (0) 7144 8990
✉ sales.de@inovance.eu
- **France-Bordeaux**
☎ +33 (0) 5594 01050
✉ sales.fr@inovance.eu
- **Spain-Barcelona**
☎ +34 93 504 94 48
✉ sales.es@inovance.eu
- **Italy-Milano**
☎ +39 (0) 2268 22318
✉ sales.it@inovance.eu
- **Turkey-Istanbul**
☎ +90 (216) 706 17 89
✉ sales.tr@inovance.eu

Asia Pacific

- **India**
Chennai (Head Office) | ☎ +91 (0) 44 4380 0201
Ahmedabad | ☎ +91 794003 4272
Mumbai | ☎ +91 22 4971 5883
New Delhi | ☎ +91 11 4165 4524
Sales Network
Kolkata, Bengaluru, Pune, Coimbatore, Hyderabad, Vadodara, Jaipur
- **South Korea-Seoul**
☎ +82 (0)2 3489 8850
✉ INOVANCEKR@inovance.eu
- **Thai - Bangkok**
☎ +669 8163 8213
✉ Thailand@inovance.com
- **Vietnam - Hanoi**
☎ +84 948118793
✉ tiendinh@inovance.com

- **China**
Shenzhen Inovance Technology Co., Ltd.
Suzhou Inovance Technology Co. Ltd.
☎ 4000-300124 (within China)
✉ info@inovance.com
✉ service@inovance.com
Hong Kong SAR (International Export Office)
☎ +852 2751 6080
✉ info@inovance.eu

FOLLOW US

Pre-sales consultation Email:
motioncontrol@inovance.com

Servo System Online Selection Tool:
<https://www.inovance.com/global/prod-select>



INOVANCE

Servo System Overview

SV680-*INT / SV670-INT

SV660(ND)-INT / SV630-INT



EtherCAT

CANlink

CANopen

PROFIBUS
NET

Modbus

Application

Widely used in automated equipment such as mobile phone manufacturing, semiconductor manufacturing, pick-and-place machines, printed circuit boards, and packaging machinery.



Table of Contents

01	<u>INOVANCE</u> Servo System Core Feature	01
02	<u>Servo</u>	
	SV680 Series	11
	SV670 Series	16
	SV660 Series	20
	SV660ND Series	24
	SV630 Series	27
03	<u>Servo Motor</u>	
	MS1-R Series motor	31
	Battery-less Multi-turn encoder motor	33
	Explosion-protected motor	35
04	<u>Cable</u>	
	S6-L-INT Series Servo Connection Cable	40
05	<u>Selection Chart</u>	45

INOVANCE Motion Control Ecosystem Network

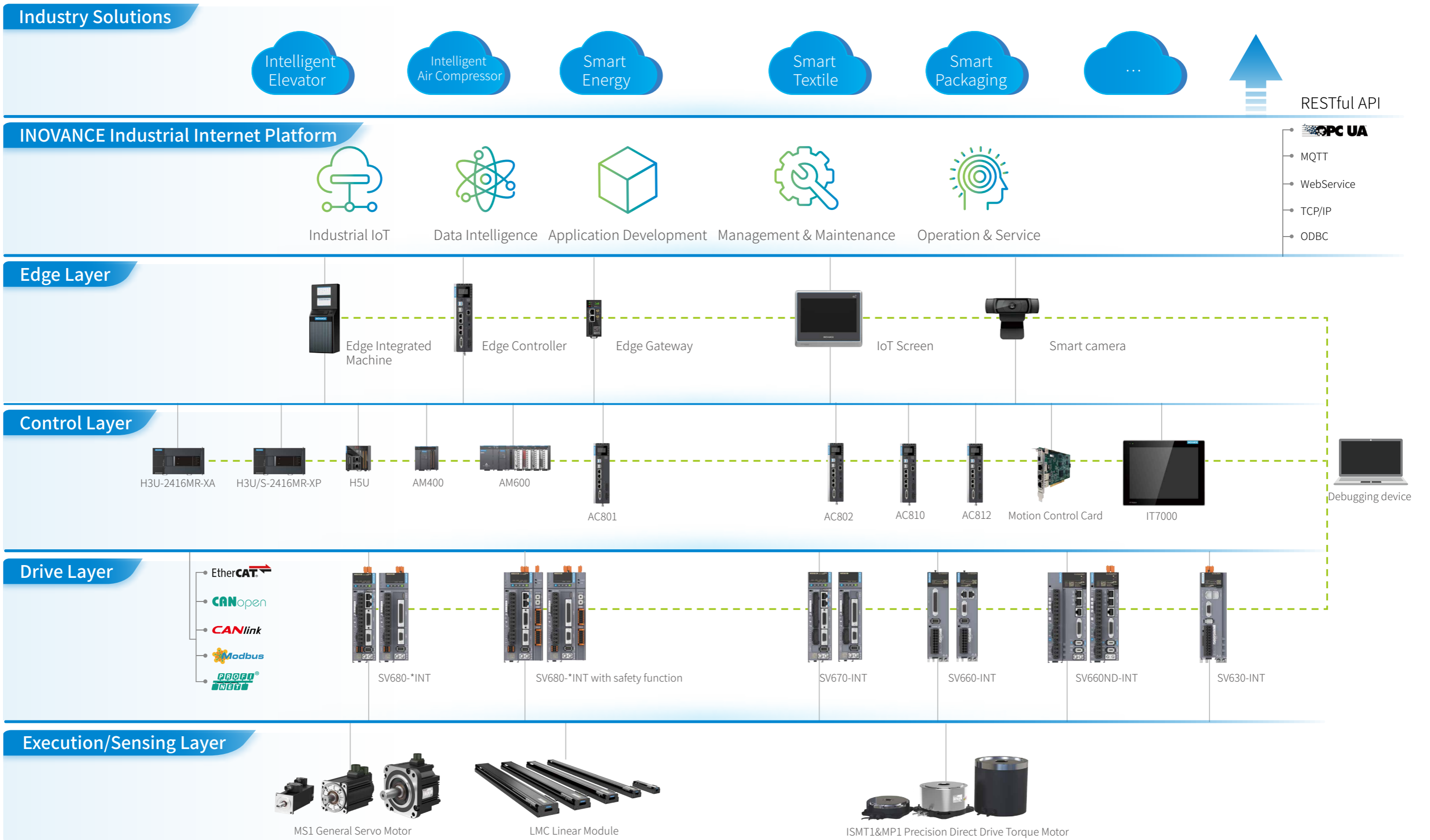

INOVANCE Servo System Core Feature*

Outstanding Performance

Industry-Leading Algorithms

- 625kHz current loop control algorithm enables smoother and more accurate command planning.
- Speed loop bandwidth frequency increased to a maximum of 3.5 kHz, enabling faster response and tracking for high-end industrial equipment.

Spec	Frequency
Frequency lower limit	12kHz
Current loop sampling	625kHz
Speed loop sampling	16kHz
Position loop sampling	16kHz

High Performance Motor

- High-Speed & High Precision: The encoder resolution of the MS1 motor is increased up to a maximum of 26-bit, the maximum speed of some models is upgraded from 6000 rpm to 7000 rpm.
- Ultra-Low Inertia Motor: Inertia is reduced by over 60%, targeting motion control scenarios requiring high-cycle, low-temperature-rise, and light-load operation—such as high-cycle die bonding arms.

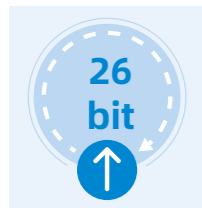

Higher Precision



Higher Speed

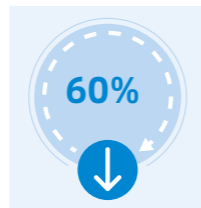

Lower Inertia

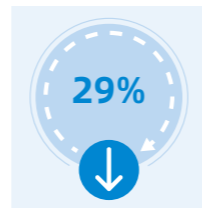

Smaller Size

Excellent Vibration Suppression Function

- Mechanical Resonance Suppression: All series are equipped with 5 notch filters broadly covering 50~8000Hz, 2 of them support adaptive settings, precisely suppressing interference;

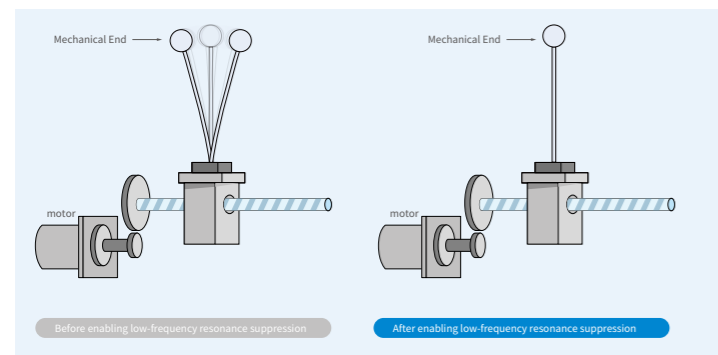
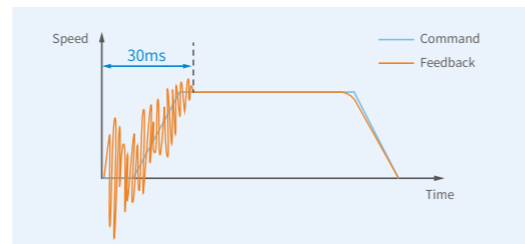

- Low-Frequency Resonance Suppression at the Mechanical End: Via advanced control algorithms, it effectively shortens the settling time required for suppressing low-frequency resonance below 100Hz, enabling more stable operation of flexible equipment.

* The core features apply to the SV Series Servo System, including SV680/SV670/SV660/SV630 series.

Easy to use

One-Click Commissioning Functions

Stune:

Single-Parameter Tuning : Simply adjust H09-01 [Rigidity Level Selection] in the corresponding mode to realize automatic inertia identification, automatic gain adjustment, and automatic resonance suppression functions with one click.

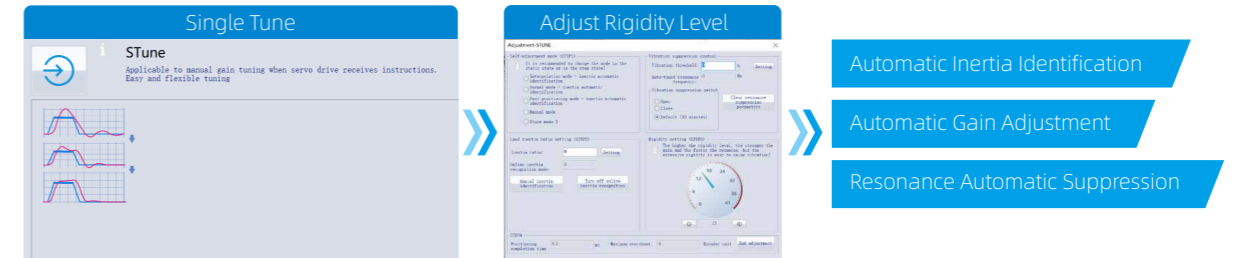

Etune:

Easy Tune : After setting the corresponding trajectory curves and response requirement parameters via guided prompts, the servo will automatically operate and learn the optimal gain parameters. Once learning is completed, the parameters can be exported as a recipe for easy batch copying.

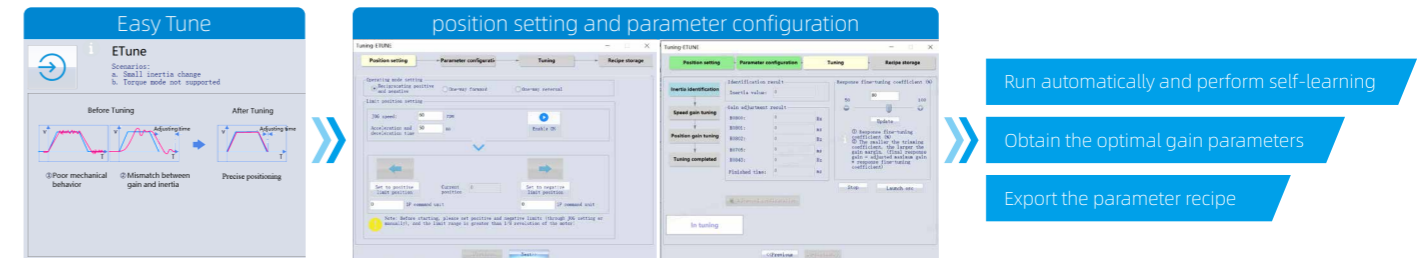

Guided-commissioning software

- All-new InoDriverShop commissioning software, lowers the threshold for servo usage.
- With guided instructions and graphical parameter configuration, servo parameter setup is easily completed.

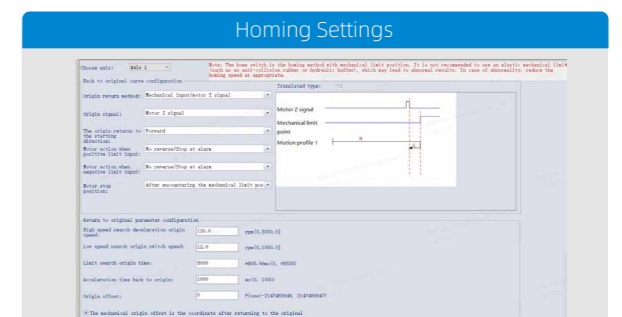
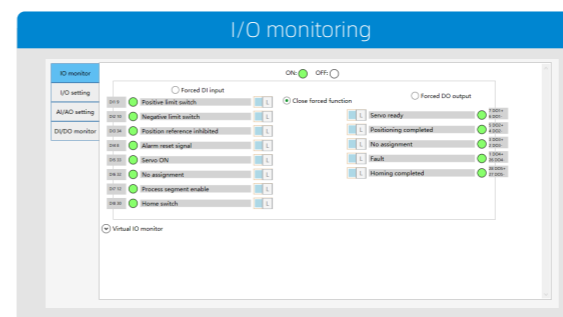
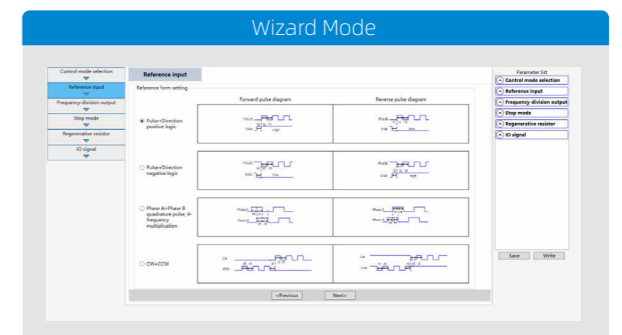

Easy installation

- Pluggable connectors for both signal and power allow avoidance of wiring mistakes.
- The absolute encoder's battery is directly attached to the drive by snap-fit joint, which is easy to remove and replace.

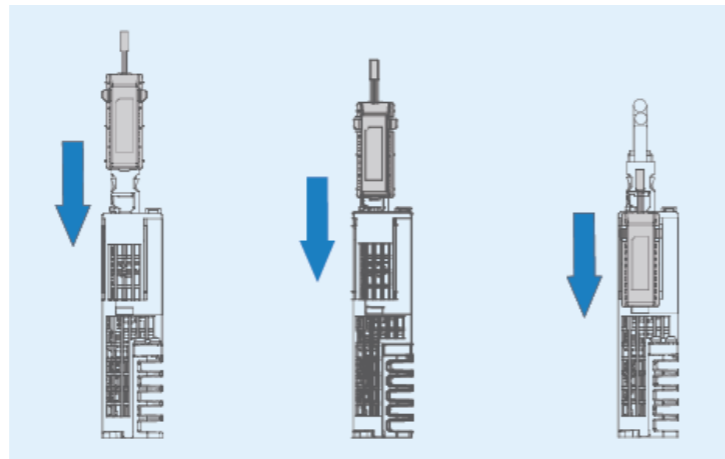

Safety Assurance

Safety Torque Off

- compliant with SIL 3 acc. to EN 61800-5-2/EN 61508
- The STO function guarantees the servo drive to stop safely without using additional contactors

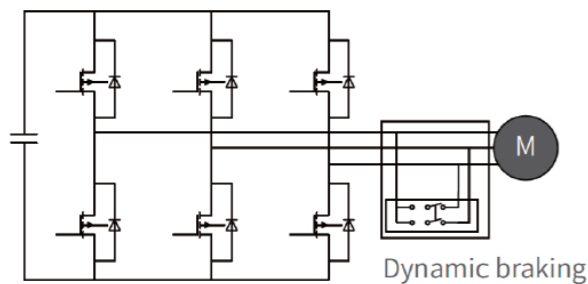
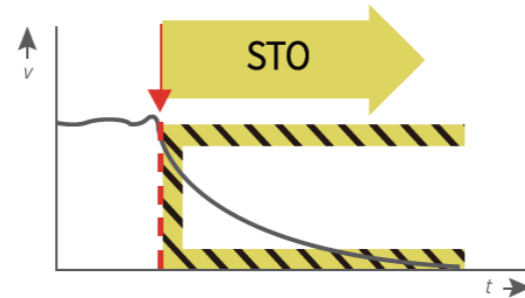

Dynamic Braking

- Built-in dynamic braking ensures safe stops if the drive is unexpectedly disabled- even in the case of a failure in the motor brake.

Designed for harsh environments

- Conformally coated PCBs are resistant to 3S2 and 3C3 environments(acc. to IEC 60721-3-3), providing further protection.
- Isolated cooling duct prevents dust contamination of internal electrical components.

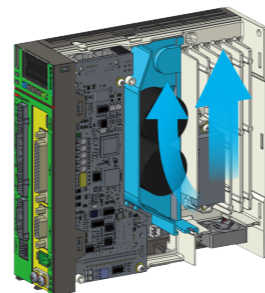

MS1-R motor with up to IP67 & IE5 rating

- Up to IP67, with standard oil and seal design
- The energy efficiency of 550w ~ 7.5 kW motor is equal to IE5 level.

Digital Intelligence

Multi-device Parameter Management—More Efficient Reading and Writing

- For EtherCAT bus servo parameter replication, all servos in a single device can complete parameter upload and download for all servos in one go via the EtherCAT network using commissioning software.

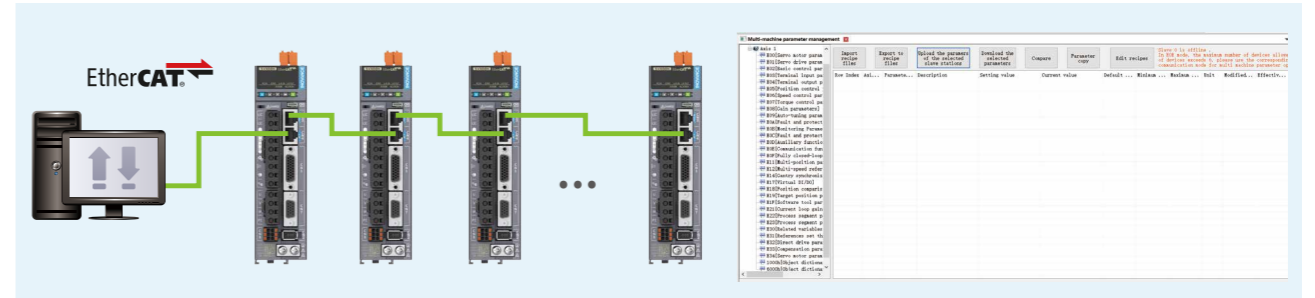

Black Box - Upgraded Fault Monitoring

- Newly added one-click reading of all channel information, eliminating the need to select specific channels. Fault records are now more comprehensive and user-friendly.



Newly Added Battery-less Multi-turn Absolute Encoder

Easy Maintenance, Easy Wiring, Easy Export

- No need to replace batteries or manage battery inventory, which can reduce maintenance costs.
- No need to wire battery cables, making wiring more convenient.
- No need to worry about the handling of lithium metal batteries during sea and air transportation, making equipment handling and transportation easier.

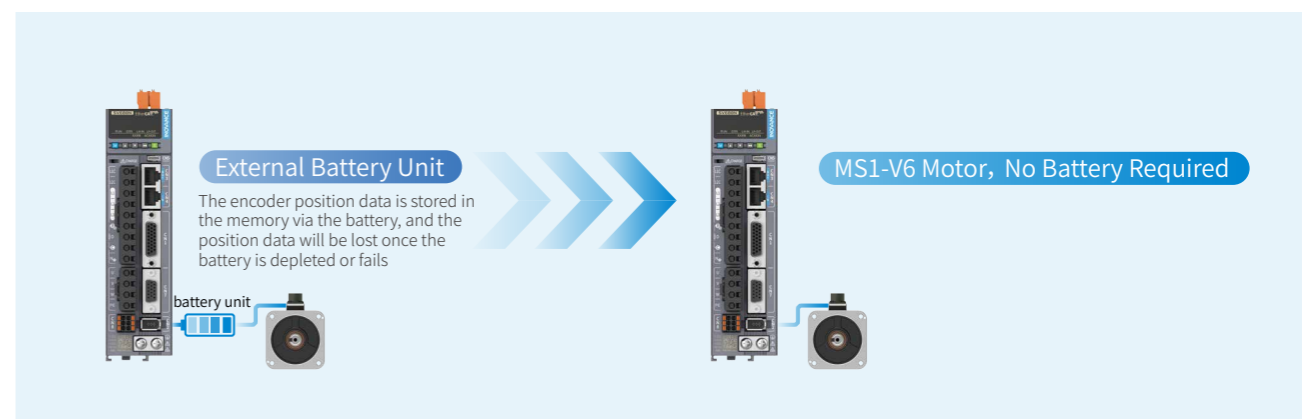

Easy Selection

- Servo motors, servo drives and cables can be selected via the selection tool.
- Accuracy assurance: Backed by the latest database, consistent with official manuals and brochures.
- Simplified Model Selection
- Complex Motor Selection - 5 Scenarios

Product parameter filter

Classify Categories: MS1-A3-INT, MS1-A6-INT, MS1-S6-INT

Flange size(mm): 40, 60, 80, 100, 130, 180

Rated power (kW): 0.05, 0.1, 0.2, 0.4, 0.55, 0.75, 0.85, 1, 1.3, 1.5, 1.8, 2, 2.5, 2.9, 3, 4, 4.4, 5, 5.5, 7.5

Inertia: H1 (Low inertia/Small capacity), H2 (Low inertia/Medium capacity), H3 (Medium inertia/Small capacity), H4 (Medium inertia/Medium capacity)

Rated torque (N·m): 0.16, 0.32, 0.64, 1.27, 1.75, 11.5, 12.6, 12.7, 15.0, 18.6, 2.39, 28.4, 3.18, 3.5, 4.9, 45, 48

Voltage level (V): 220, 380

Rated speed (rpm): 1500, 3000

Max. speed (rpm): 4500, 6000, 7000

Encoder: A3-23-bit multturn absolute encoder, A6-26-bit multturn absolute encoder, S6-Functional safety type 26-bit multturn absolute encoder

Brake: No, Yes



- Guided Selection: Simply follow the step-by-step guidance to complete selection easily, fast and efficiently.

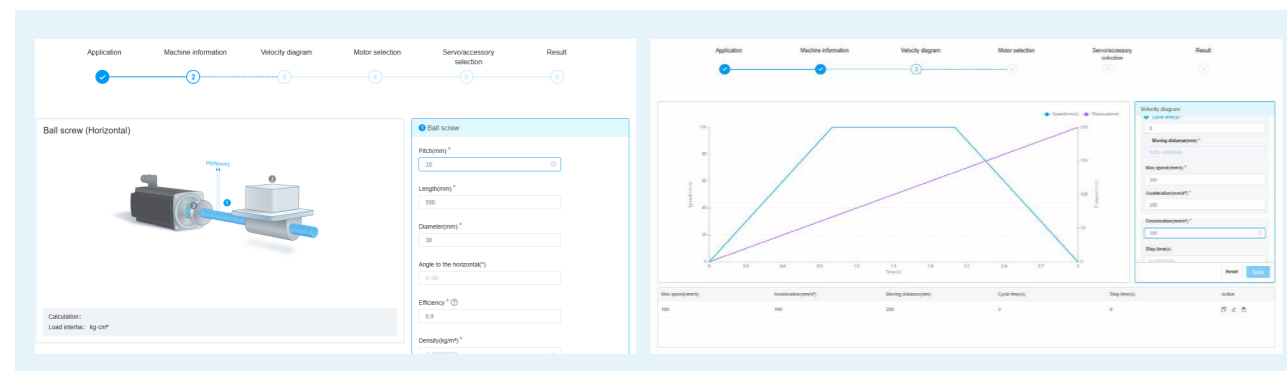

- With entered data, it automatically calculates load inertia, rotational speed, torque and more - then recommends suitable motors and provides parameter comparisons.
- Selection lists and detailed parameters are generated automatically, and can be exported with one click.

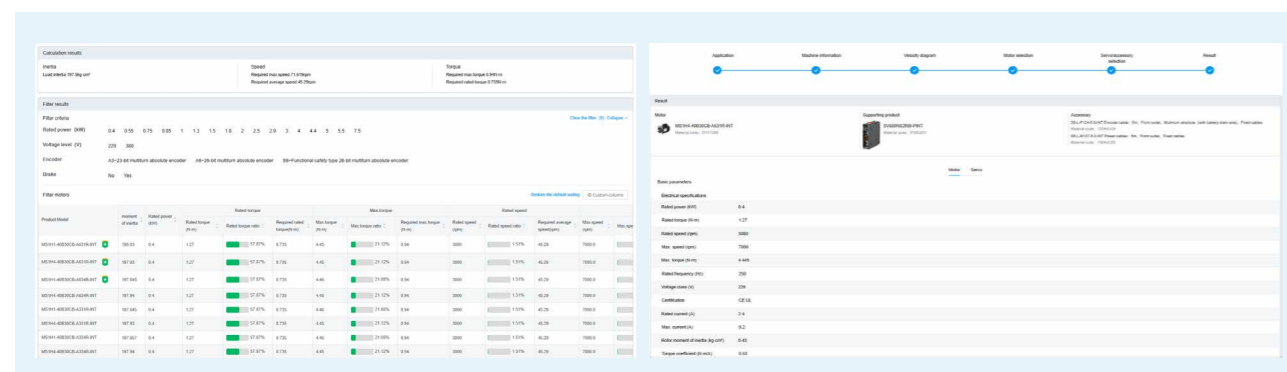

*Servo System Online Selection : <https://www.inovance.com/global/prod-select>

Naming Description

Servo Drive

SV670 N S 2R8 I - FS - INT

① ② ③ ④ ⑤ ⑥ ⑦

<p>① Product series SV680: SV680 series servo drive SV670: SV670 series servo drive SV660: SV660 series servo drive SV630: SV630 series servo drive</p>	<p>④ Rated output current</p> <p>S: 200V T: 380V</p>	<p>⑤ Model configuration I: Standard type S: Advanced functional safety type with 24V DC backup for SV680 only</p>
<p>② Product type N: EtherCAT P: Pulse F: PROFINET A: CANlink C: CANopen ND: EtherCAT Dual-axis for SV660 only</p>	<p>1R6: 1.6 A 3R5: 3.5 A 2R8: 2.8 A 5R4: 5.4 A 5R5: 5.5 A 8R4: 8.4 A 7R6: 7.6 A 012: 12.0 A 012: 12.0 A 017: 17.0 A 018: 18.0 A 021: 21.0 A 022: 22.0 A 026: 26.0 A 027: 27.0 A</p>	<p>⑥ Optional configuration^[3] FS: with STO None: without STO</p>
<p>③ Voltage class^[2] S: 220V T: 380V</p>		<p>⑦ Model configuration^[4] INT: International Version GINT: General-purpose type for SV680 only PINT: 24V DC backup power supply type for SV680 only</p>

Note: [1] The explanations for each segment are general interpretations. Not all product series support all configuration options listed in the rule.
 [2] For voltage class, the voltage range for S-220V is uniformly 200V ~ 240V; for T-380V, the voltage range is 380V ~ 480V for the SV680/SV670 series, and 380V ~ 440V for the SV660/SV630 series.
 [3] The SV680 series comes standard with STO, and the "Optional configuration" part is not included in its naming.
 [4] For SV680 series, if the safety module is required, Order the SV680XXXS-GINT version; if 24V DC backup function is required for the standard type, order the PINT version; the INT version for SV680 is not selectable

Servo Motor

MS1 H1- 75B 30C B - A3 3 1 R - * - INT

① ② ③ ④ ⑤ ⑥ ⑦ ⑧ ⑨ ⑩ ⑪

<p>① Product series MS1: MS1 series servo motor</p>	<p>④ Rated speed (rpm) Comprised of a letter and two digits B: x 10 C: x 100 Example: 30C refers to 3000 rpm</p>	<p>⑦ Shaft connection mode 3: Solid and keyed, with threaded hole in the shaft center</p>
<p>② Inertia and capacity type H1: Low inertia, small capacity H2: Low inertia, medium capacity H3: Medium inertia, medium capacity H4: Medium inertia, small capacity</p>	<p>⑤ Voltage class B: 200V D: 400V</p>	<p>⑧ Brake or oil seal^[1] 0: Without oil seal or brake 1: With oil seal, without brake 2: Without oil seal, with brake 4: With oil seal and brake</p>
<p>③ Rated power (W) Comprised of a letter and two digits B: x 10 C: x 100 Example: 75B refers to 750W</p>	<p>⑥ Encoder type A6: 26-bit multi-turn absolute encoder S6: 26-bit multi-turn absolute encoder of safety function V6: 26-bit multi-turn absolute battery-less encoder A3: 23-bit multi-turn absolute encoder V3: 23-bit multi-turn absolute battery-less encoder T3: 18-bit multi-turn absolute encoder</p>	<p>⑨ Sub-series No. R: R series</p>
		<p>⑩ Customization information None: Standard type -S: Flying leads type -**: Other customized types</p>
		<p>⑪ Model type INT: International Version</p>

Note: [1] H1 type motors with a 40mm flange size are not equipped with an oil seal.
 [2] Battery-less encoder motors do not have 40mm frame-size options (with powers of 50W and 100W).
 [3] Motor electrical data and mechanical dimensions between MS1-V6/V3 motor and MS1-A6/A3 motor are same.

SV680 Series

Flagship Servo Drive



Product Feature

- 26-bit Multi-turn Absolute Encoder
- 3.5 kHz Speed Loop Bandwidth
- 8 Function safety & FSoE
- PTC Temperature Detection
- USB-C port for commissioning
- Support DDR&DDL and third-party motor
- Gantry Synchronization Function
- Full closed loop function

Type	Pulse	RS-485	CANopen	EtherCAT	Profinet	full closed loop	Frequency division output	STO	DI/DO	AI/AO
680P	○	○	○	-	-	○	○	○	8DI/5DO	2AI/1AO
680N	-	-	-	○	-	○	○	○	5DI/2DO	2AI/1AO
680F	-	-	-	-	○	○	○	○	5DI/2DO	2AI/1AO

High Precision & Fast Response

- The 26-bit Multi-turn Absolute Encoder provides more than 671 million pulses within one mechanical turn, ensuring precise positioning
- A speed loop response bandwidth of 3.5 kHz* gives significantly improved performance

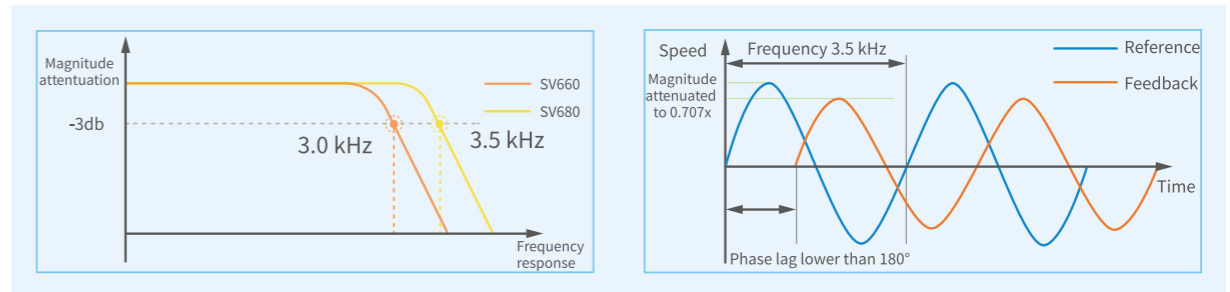

*Please note: The statement refers to the highest frequency speed command change that the servo system can respond to.

Advanced Functional Safety (FSoE / PROFIsafe)

SV680xxxS-GINT version supports advanced functional safety functions, with the following features:

- **FSoE** (Fail Safe over EtherCAT) safe protocol and PROFIsafe based on PROFINET, compliant to SIL 3 PL e.
- 8 safety functions according to IEC 61800-5-2 SIL 3: STO, SS1, SS2, SOS, SSM, SBC, SDI, SLS.
- 5 digital safety inputs and 6 digital safety outputs.
- Two ways to activate advanced safety functions, through I/O or through communications with **FSoE/PROFIsafe**.

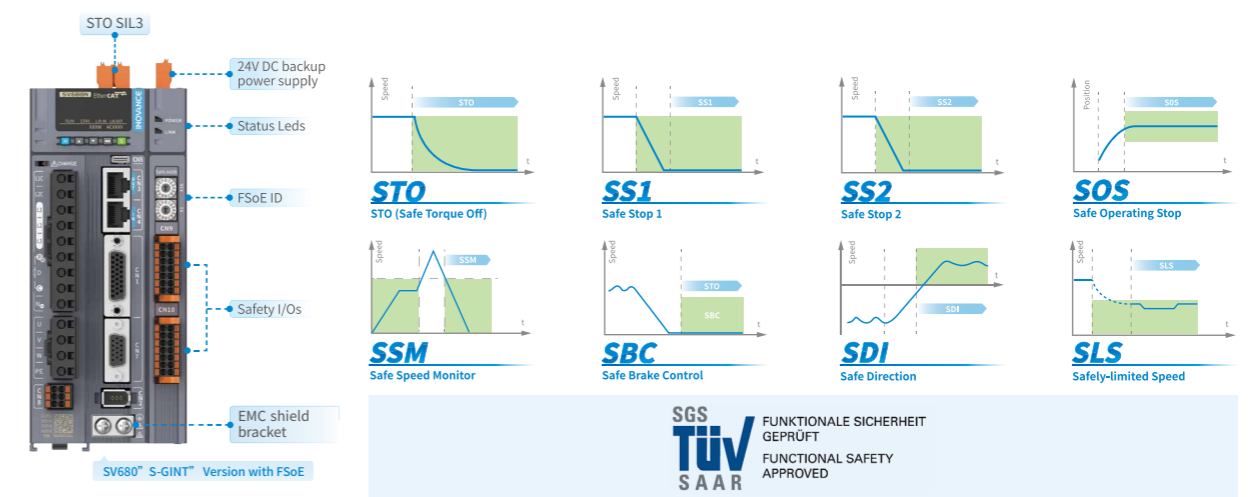
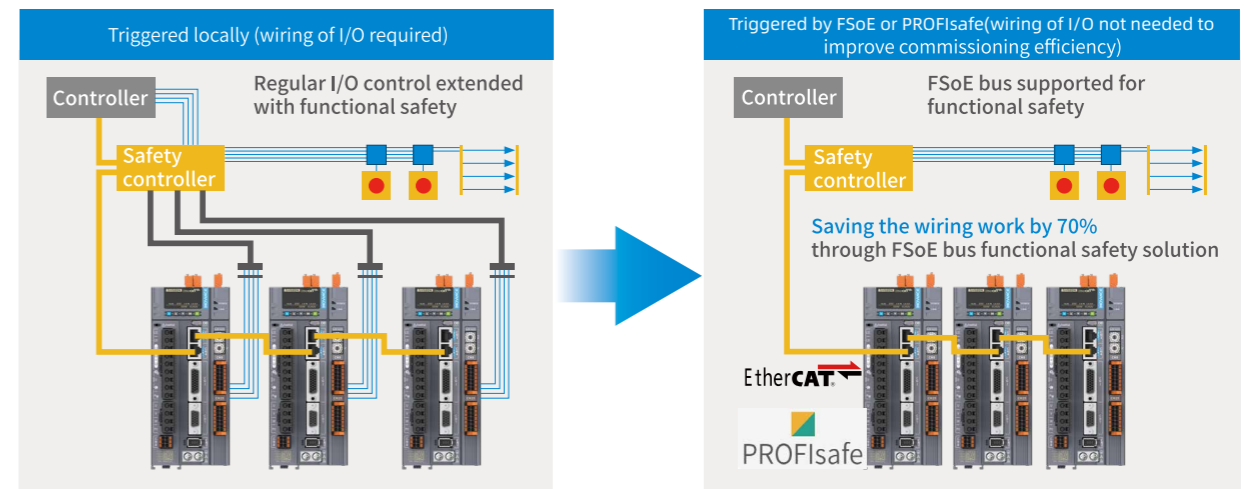

Wide adaptability

- Direct-drive motor supported: SV680-*INT supports direct-drive motors (DDL&DDR) and is compatible with Inovance communication encoders, as well as various third-party encoders. For DDL&DDR motors, accuracy compensation function is available.
- The SV680 servo drive as standard, supports EnDat 2.2, BiSS-C, SSI and ABZ incremental encoders fitted to customer's choice of servo motor.



Easy commissioning and wiring

- Connect to a PC using standard USB-C cable for parameter upload/download and firmware upgrade – no external power supply required.
- Built-in Brake Relay reduces wiring time and shorts brake response delay

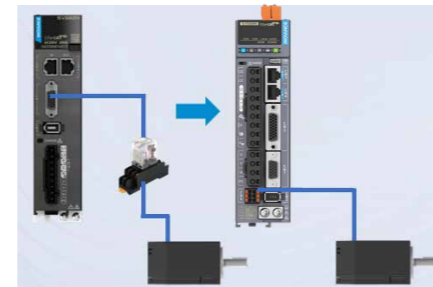
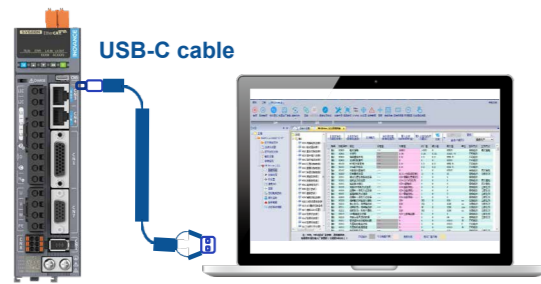

Gantry synchronization

- The position error between two axes can be reduced to 1/5000 of a revolution for a travel distance of 1.2 m.
- Multiple gantry alignment modes are available, including: alignment after enabling the axis, by home, by torque or by digital input.

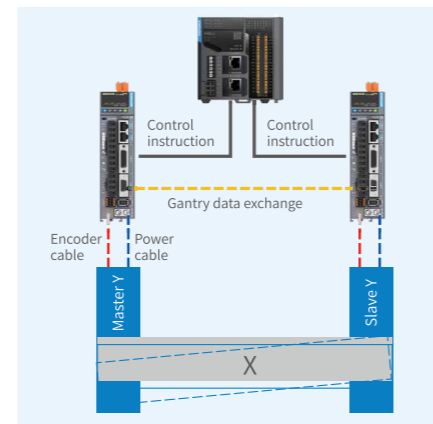

Compatible with multiple Profinet bus controllers

- The SV680F seamlessly interfaces with PROFINET controllers including S7-1200, S7-1500, and SIMOTION, fully compliant with the PROFIdrive profile.

- Telegram types supported by SV680F

Code	Configuration	Description
AC1	Standard Telegram 1, 2	Closed-loop speed control
AC3	Siemens Telegram 111	EPOS drive-embedded positioning mode with integrated torque limitation via PROFIdrive telegrams
AC4	Standard Telegram 3	Controller-based closed-loop positioning
	Siemens Telegram 102, 105	Controller-based closed-loop positioning with integrated torque limitation via PROFIdrive telegrams
	Extended Telegram 750	Closed-loop torque control
	Inovance Extended Telegram 850	Communication given DI/DO
	Safety Telegrams 30, 901 (PROFIsafe Certified)	Trigger safety function

Electrical Specifications

Single-phase 220V drive

Item	SIZE-A	SIZE-C	SIZE-D	SIZE-E	
Servo Drive Model	S1R6	S2R8	S5R5	S7R6	S012
ArmsDrive Power (kW)	0.2	0.4	0.75	1.0	1.5
Continuous output current (Arms)	1.6	2.8	5.5	7.6	12.0
Max. output current (Arms)	5.8	10.1	16.9	23.0	32.0
Main circuit power supply	Single-phase 200 V AC-240 V AC, -10% to +10%, 50 Hz/60 Hz				
Control circuit power supply	Single-phase 200 V AC-240 V AC, -10% to +10%, 50 Hz/60 Hz				
Control circuit backup power circuit	24 VDC, ±15% (only applicable to PINT models with backup power)				
Braking resistor	All series support both built-in and external brake resistors; only Size A does not come with built-in resistors as standard.				

Three-phase 220V drive

Item	SIZE-A	SIZE-C	SIZE-D	SIZE-E				
Servo Drive Model	S1R6	S2R8	S5R5	S7R6	S012	S018	S022	S027
Drive Power (kW)	0.2	0.4	0.75	1.0	1.5	2.0	3.0	5.0
Continuous output current (Arms)	1.6	2.8	5.5	7.6	12.0	18.0	22.0	27.0
Max. output current (Arms)	5.8	10.1	16.9	23.0	32.0	45.0	55.0	67.5
Main circuit power supply	3-phase 200 V AC-240 V AC, -10% to +10%, 50 Hz/60 Hz							
Control circuit power supply	Single-phase 200 V AC-240 V AC, -10% to +10%, 50 Hz/60 Hz							
Control circuit backup power circuit	24 VDC, ±15% (only applicable to PINT models with backup power)							
Braking resistor	All series support both built-in and external brake resistors; only Size A does not come with built-in resistors as standard.							

Three-phase 400V drive

Item	SIZE-C	SIZE-D	SIZE-E				
Servo Drive Model	T3R5	T5R4	T8R4	T012	T017	T021	T026
Drive Power (kW)	1.0	1.5	2.0	3.0	5.0	6.0	7.5
Continuous output current (Arms)	3.5	5.4	8.4	12.0	17.0	21.0	26.0
Max. output current (Arms)	11.0	14.0	20.0	30.0	42.5	52.5	65.0
Main circuit power supply	3-phase 380 V AC-480 V AC, -10% to +10%, 50 Hz/60 Hz						
Control circuit power supply	Single-phase 380 V AC-480 V AC, -10% to +10%, 50 Hz/60 Hz						
Control circuit backup power circuit	24 VDC, ±15% (only applicable to PINT models with backup power)						
Braking resistor	All series support both built-in and external brake resistors						





Dimensions

Models without 24V DC backup		Frame size	W (mm)	H (mm)	D (mm)	Weight (kg)
SV680N****I-GINT	SV680P****I-GINT					
		SIZE A	45.5	170	150	0.96
		SIZE C	55±1	170	173±1	1.30
		SIZE D	80±1	170	183	1.80
		SIZE E	90	250	230	3.60

Models with 24V DV backup and Functional Safety Module		Frame size	W (mm)	H (mm)	D (mm)	Weight (kg)
SV680N****S-GINT & SV680N****-PINT	SV680P****S-GINT & SV680P****-PINT					
		SIZE A	64.5	170	150	1.11
		SIZE C	74±1	170	173±1	1.45
		SIZE D	99±1	170	183	1.95
		SIZE E	109	250	230	3.75

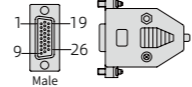
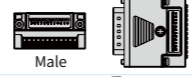
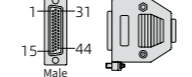
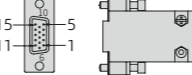
Note: Dimensions shown are for the drive module excluding the dimensions of the EMC shield brackets, terminals and DB connectors (refer to user guide).

Accessories

Description	Model	Outline Drawing
CN1 connector (DB26)	S6-C74	
SV680N/SV680F CN1 IO DB26 to 14 push-in adapter	S6-C220	
CN1 connector (DB44)	S6-C8	
CN7 connector (DB15)	S6-C6	
Shield bracket	S6-C25 (optional for sizes A and C) S6-C27 (optional for size D to size E)	
Battery box kit (without battery)	S6-C4A-NB	
Battery kit	S6-C4A	

SV670 Series

High-Performance Servo Drive



Product Feature

- 23-bit Multi-turn Absolute Encoder
- 3.2 kHz Speed Loop Bandwidth
- USB-C port for commissioning
- Support DDR&DDL and third-party motor
- Full closed loop function
- Separate control power

Type	Pulse	RS-485	CANopen	CANlink	EtherCAT	Profinet	full closed loop	Frequency division output	STO ^[1]	DI/DO	AI/AO
670P	○	○	○	○	-	-	○	○	*	8DI/5DO	2AI/1AO
670N	-	-	-	-	○	-	○	○	*	5DI/2DO	2AI/1AO

Note: [1] STO function is selectable for all models

Speed loop bandwidth*

A speed loop response bandwidth of 3.2 kHz gives significantly improved performance compared to the previous generation of Inovance products.

SV670	
Carrier frequency	12 kHz
Current loop cycle time	1.6 μs
Speed loop cycle time	62.5 μs
Position loop cycle time	62.5 μs

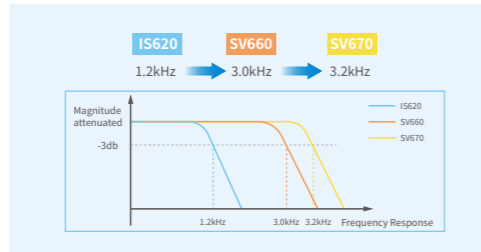

*Please note: The phrase 'speed loop bandwidth' refers to the highest frequency speed command change that the servo system can respond to.

Encoder interfaces

23 bit single/multi-turn absolute encoder provides 8,388,608 pulses within one mechanical turn. Following types of encoders are supported: INOVANCE serial type (23 bits, absolute multiturn), ABZ incremental encoders.

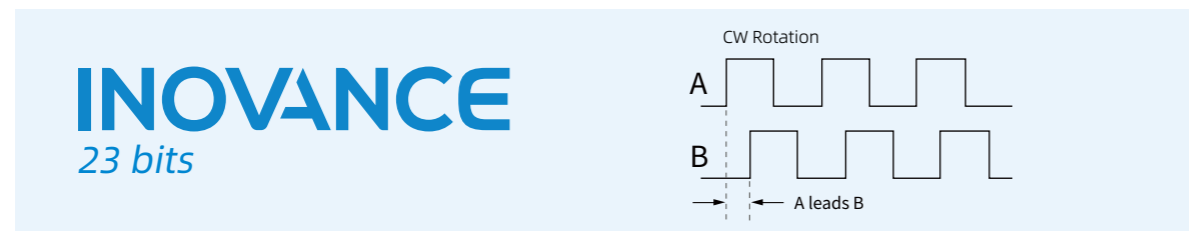

Function Improvements

- Full Closed Loop Function: Supports ABZ orthogonal pulse full closed-loop to ensure the positioning accuracy of the device

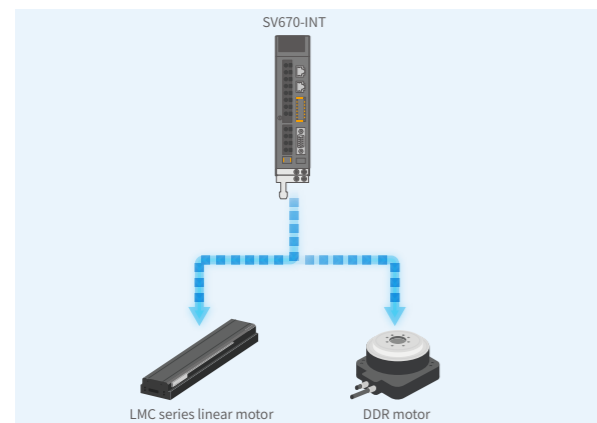
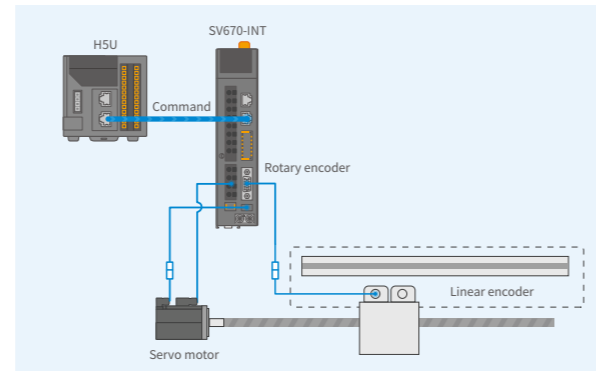

- DDL & DDR support: Supports linear motors + DDR motor, meeting a wide range of application scenarios

Electrical Specifications

Single-phase 220V drive

Item	SIZE-A		SIZE-C		SIZE-D
Servo Drive Model	S1R6	S2R8	S5R5	S7R6	S012
ArmsDrive Power (kW)	0.2	0.4	0.75	1.0	1.5
Continuous output current (Arms)	1.6	2.8	5.5	7.6	12.0
Max. output current (Arms)	5.8	10.1	16.9	23.0	32.0
Main circuit power supply	Single-phase 200 V AC-240 V AC, -10% to +10%, 50 Hz/60 Hz				
Control circuit power supply	Single-phase 200 V AC-240 V AC, -10% to +10%, 50 Hz/60 Hz				
Braking resistor	All series support both built-in and external brake resistors; only Size A does not come with built-in resistors as standard.				



Three-phase 220V drive

Item	SIZE-A		SIZE-C		SIZE-D	SIZE-E		
Servo Drive Model	S1R6	S2R8	S5R5	S7R6	S012	S018	S022	S027
Drive Power (kW)	0.2	0.4	0.75	1.0	1.5	2.0	3.0	5.0
Continuous output current (Arms)	1.6	2.8	5.5	7.6	12.0	18.0	22.0	27.0
Max. output current (Arms)	5.8	10.1	16.9	23.0	32.0	45.0	55.0	67.5
Main circuit power supply	3-phase 200 V AC-240 V AC, -10% to +10%, 50 Hz/60 Hz							
Control circuit power supply	Single-phase 200 V AC-240 V AC, -10% to +10%, 50 Hz/60 Hz							
Braking resistor	All series support both built-in and external brake resistors; only Size A does not come with built-in resistors as standard.							

Three-phase 400V drive



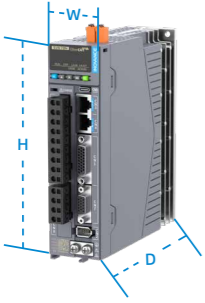



Item	SIZE-C		SIZE-D		SIZE-E		
Servo Drive Model	T3R5	T5R4	T8R4	T012	T017	T021	T026
Drive Power (kW)	1.0	1.5	2.0	3.0	5.0	6.0	7.5
Continuous output current (Arms)	3.5	5.4	8.4	12.0	17.0	21.0	26.0
Max. output current (Arms)	11.0	14.0	20.0	30.0	42.5	52.5	65.0
Main circuit power supply	3-phase 380 V AC-480 V AC, -10% to +10%, 50 Hz/60 Hz						
Control circuit power supply	Single-phase 380 V AC-480 V AC, -10% to +10%, 50 Hz/60 Hz						
Braking resistor	All series support both built-in and external brake resistors						

Dimensions

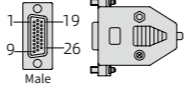
Models without 24V DC backup		Frame size	W (mm)	H (mm)	D (mm)	Weight (kg)
SV670N****I (-FS) -INT	SV670P****I (-FS) -INT					
		SIZE A	45.5	170	150	0.96
		SIZE C	55±1	170	173±1	1.30
		SIZE D	80±1	170	183	1.80
		SIZE E	90	250	230	3.60

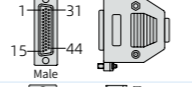
Note: Dimensions shown are for the drive module excluding the dimensions of the EMC shield brackets, terminals and DB connectors (refer to user guide).

Accessories

Description	Model	Outline Drawing
CN1 connector (DB26)	S6-C74	
SV670N CN1 IO DB26 to 14 push-in adapter	S6-C220	
CN1 connector (DB44)	S6-C8	
CN7 connector (DB15)	S6-C6	
Shield bracket	S6-C25 (optional for sizes A and C) S6-C27 (optional for size D to size E)	
Battery box kit (without battery)	S6-C4A-NB	
Battery kit	S6-C4A	

SV660 Series

General-purpose Servo Drive



Product Feature

- 23-bit Multi-turn Absolute Encoder
- 3.0 kHz Speed Loop Bandwidth
- Multiple Communication Methods Available
- User friendly installation
- Easy set-up and tuning
- High power density

Type	Pulse	RS-485	CANopen	CANlink	EtherCAT	Profinet	Frequency division output	STO ^[1]	DI/DO	AI/AO
660P	○	○	○	○	-	-	○	-	7DI/5DO	-
660N	-	-	-	-	○	-	-	*	5DI/2DO	-
660F	-	-	-	-	-	○	-	*	5DI/3DO	-
660C	-	○	○	-	-	-	○	-	7DI/5DO	-
660A	-	○	-	○	-	-	○	-	7DI/5DO	-

Note: [1] STO function is selectable for N and F models

Electrical Specifications

Single-phase 220V drive

Item	SIZE-A	SIZE-B	SIZE-C	SIZE-D	
Servo Drive Model	S1R6	S2R8	S5R5	S7R6	S012
Drive Power (kW)	0.2	0.4	0.75	1.0	1.5
Continuous output current (Arms)	1.6	2.8	5.5	7.6	12.0
Max. output current (Arms)	5.8	10.1	16.9	23.0	32.0
Main circuit power supply	Single-phase 200 V AC-240 V AC, -10% to +10%, 50 Hz/60 Hz				
Control circuit power supply	Powered up by the bus, no need for separate power supply		Single-phase 200 V AC-240 V AC, -10% to +10%, 50 Hz/60 Hz		
Braking resistor	All series support both built-in and external brake resistors; only Size A does not come with built-in resistors as standard.				

Three-phase 220V drive

Item	SIZE-C	SIZE-D
Servo Drive Model	S7R6	S012
Drive Power (kW)	1.0	1.5
Continuous output current (Arms)	7.6	11.6
Max. output current (Arms)	23.0	32.0
Main circuit power supply	3-phase 200 V AC-240 V AC, -10% to +10%, 50 Hz/60 Hz	
Control circuit power supply	Single-phase 200 V AC-240 V AC, -10% to +10%, 50 Hz/60 Hz	
Braking resistor	Built-in and external resistor is supported	

Three-phase 400V drive

Item	SIZE-C	SIZE-D	SIZE-E				
Servo Drive Model	T3R5	T5R4	T8R4	T012	T017	T021	T026
Drive Power (kW)	1.0	1.5	2.0	3.0	5.0	6.0	7.5
Continuous output current (Arms)	3.5	5.4	8.4	11.9	16.5	20.8	25.7
Max. output current (Arms)	11.0	14.0	20.0	29.75	41.25	52.12	64.25
Main circuit power supply	3-phase 380 V AC-480 V AC, -10% to +10%, 50 Hz/60 Hz						
Control circuit power supply	Single-phase 380 V AC-480 V AC, -10% to +10%, 50 Hz/60 Hz						
Braking resistor	All series support both built-in and external brake resistors						

Control Performance

A speed loop response bandwidth of 3kHz gives significantly improved performance compared to the previous generation of Inovance products.*

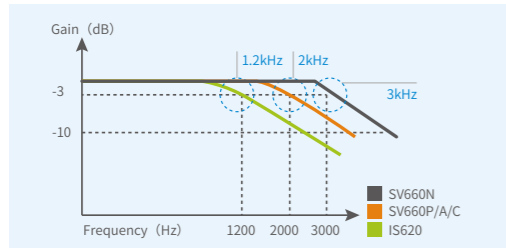

*Please note: The phrase 'speed loop bandwidth' refers to the highest frequency speed command change that the servo system can respond to.

Positioning Accuracy

23 bit serial single/multi-turn absolute encoder provides 8,388,608 pulses within one mechanical turn. Multi-turn absolute information can be also saved at power down, avoiding the need to perform machine homing at every power-up.

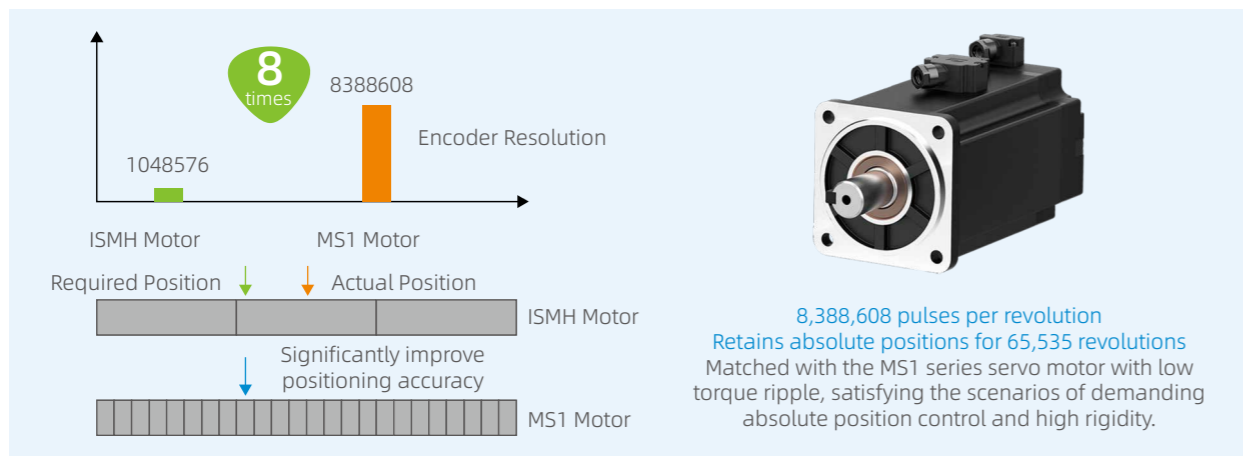

Compatible with Multiple PROFINET Bus Controllers

- PROFINET RT handle time-critical data, with cycle times down to 1ms, meeting most industrial timing needs; PROFINET IRT goes further: it reduces communication delays for deterministic, synchronized communication with cycle time down to 500 μs.
- The PROFIdrive implementation in the SV660F supports the following application classes:

- AC1 adjustable-speed drives with/without technology function
- AC3 drives with positioning function
- AC4 synchronous servo applications and high-performance motion control applications



- Depending on the application class, the SV660F supports the telegrams 1, 2, 3, 102, 111, 105, 750.

Compact Size, Enhanced Power Density

With innovative design and next-gen power devices, the SV660 servo drive achieves a 30% volume reduction.

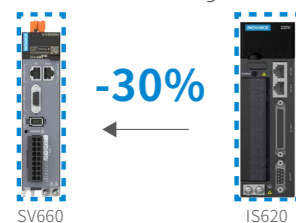

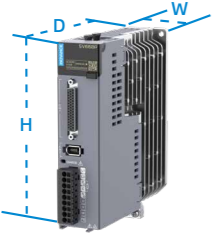
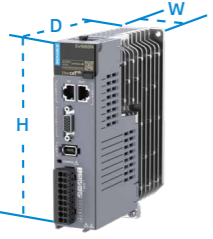

	SV660	IS620	
400W	Width (mm)	40	50
	Height (mm)	160	160
	Depth (mm)	150	173
	Volume (L)	0.96	1.38
Compare with IS620		-30%	

Dimensions

SV660P	SV660N	Frame size	L (mm)	H (mm)	D (mm)	Mounting hole	Weight (kg)
		SIZE A	40	170	150	2-M4	0.8
		SIZE B	50	170	173	2-M4	1.0
		SIZE C	55±1	170	173±1	2-M4	1.3
		SIZE D	80±1	170	183	3-M4	1.8
		SIZE E	90	250	230	4-M4	3.6

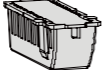
Accessories

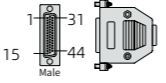
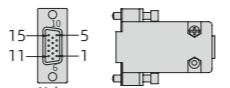
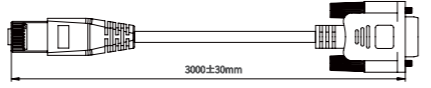
Description	Model	Outline Drawing
Battery box kit (without battery)	S6-C4A-NB	
Battery kit	S6-C4A	
CN1 connector (DB44) (for SV660P)	S6-C8	
CN1 connector (DB15) (for SV660N)	S6-C6	
PC communication cable	S6-L-T00-3.0	

SV660ND Series

Dual-Axis Servo Drive



EtherCAT®

Product Feature

- 23-bit Multi-turn Absolute Encoder
- 3.0 kHz Speed Loop Bandwidth
- Compact size: More than 30% space saving
- Zero-distance installation
- EtherCAT support
- STO function available (SIL3)

Type	Pulse	RS-485	CANopen	CANlink	EtherCAT	Profinet	Frequency division output	STO ^[1]	DI/DO	AI/AO
660ND	-	-	-	-	○	-	-	*	8DI/5DO	1AI/1AO

Note:[1]STO function is selectable

Space-saving

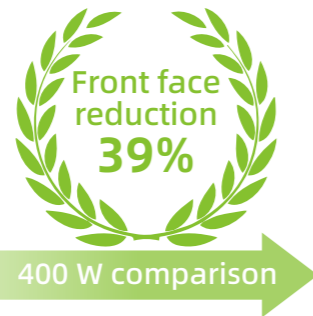

Front dimensions
(Calculated based on the normal heat dissipation distance of 10 mm)

Original dimensions:
170 mm x 90 mm

Current dimensions:
170 mm x 55 mm

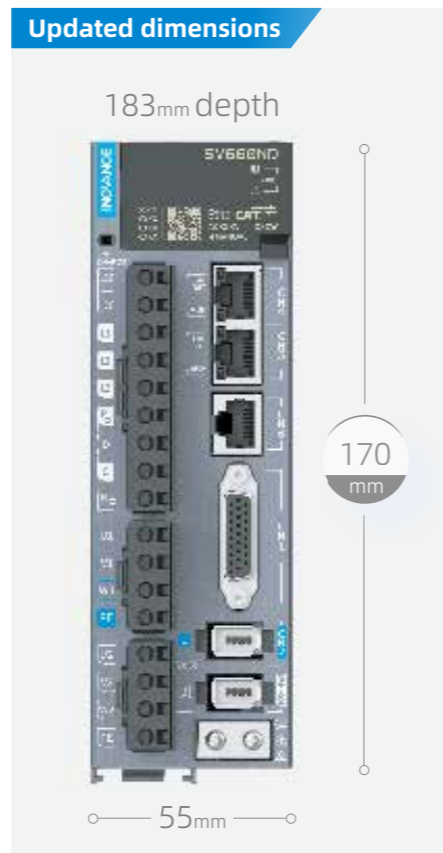

Zero-distance installation, no derating required

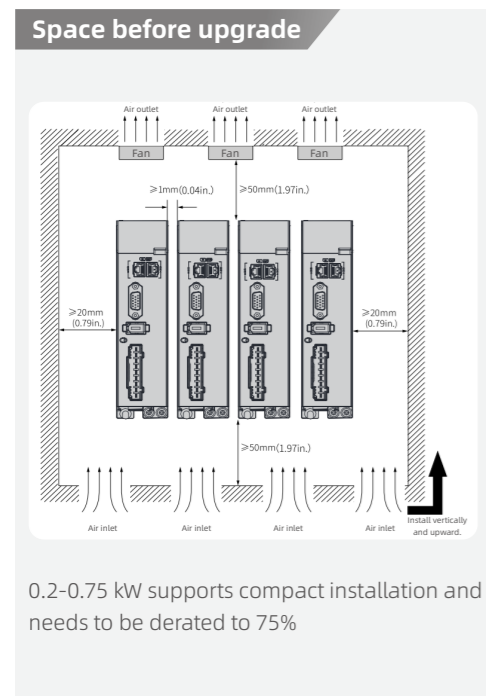

The cooling space required for eight 750w single-axis units is as follows:

Original:
447 mm x 270 mm
(With heat dissipation, compact installation)

Now
340 mm x 270 mm
(With heat dissipation, zero-pitch installation)

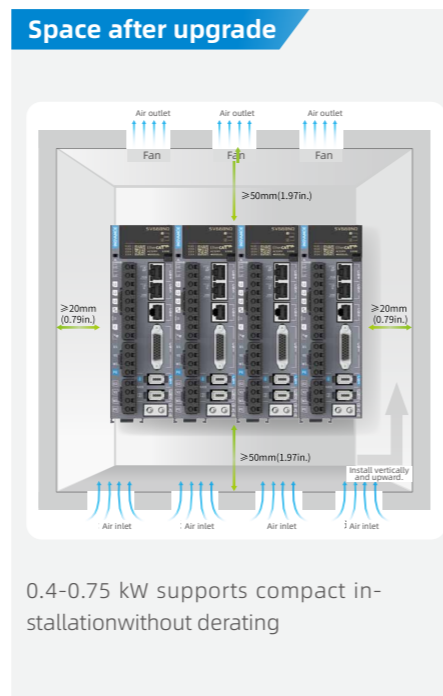

Electrical Specifications

Single-phase 220V drive

Item	SIZE-A	SIZE-B
Servo Drive Model	S2R8	S5R5
Drive Power (kW)	0.4*2	0.75*2
Continuous output current (Arms)	2.8	5.5
Max. output current (Arms)	10.1	16.9
Main circuit power supply	Single-phase 200 V AC-240 V AC, -10% to +10%, 50 Hz/60 Hz	
Control circuit power supply	Single-phase 200 V AC-240 V AC, -10% to +10%, 50 Hz/60 Hz	
Braking resistor	No built-in resistor, external resistor is supported	Built-in and external resistor is supported

Three-phase 220V drive

Item	SIZE-A	SIZE-B
Servo Drive Model	S2R8	S5R5
Drive Power (kW)	0.4*2	0.75*2
Continuous output current (Arms)	2.8	5.5
Max. output current (Arms)	10.1	16.9
Main circuit power supply	3-phase 200 V AC-240 V AC, -10% to +10%, 50 Hz/60 Hz	
Control circuit power supply	Single-phase 200 V AC-240 V AC, -10% to +10%, 50 Hz/60 Hz	
Braking resistor	No built-in resistor, external resistor is supported	Built-in and external resistor is supported

Dimensions

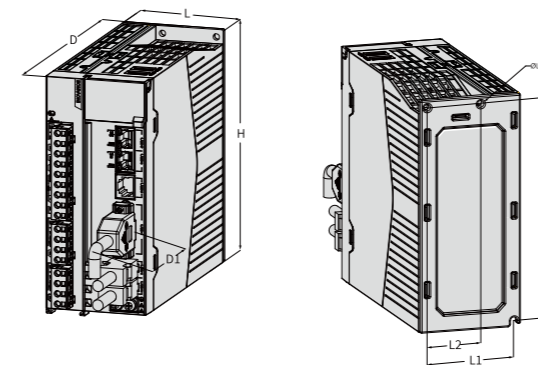

Frame size	L (mm)	H (mm)	D (mm)	L1 (mm)	L2 (mm)	H1 (mm)	D1 (mm)	Screw Hole	Tightening torque (N·m)	Weight (kg)
Size A	55 (2.17)	170 (6.69)	183 (7.20)	45 (1.77)	/	160 (6.30)	75 (2.95)	2-M4	1, 2	1.4
Size B	75 (2.95)	170 (6.69)	183 (7.20)	65 (2.56)	40 (1.57)	160 (6.30)	75 (2.95)	3-M4	1, 2	1.8

SV630-INT

Economy Servo Drive



Product Feature

- 18-bit Multi-turn Absolute Encoder
- 2 kHz Speed Loop Bandwidth
- High Resistance to Pollution and Vibration
- SV630N model with STO(SIL3)
- Compact design
- User Friendly

Type	Pulse	RS-485	CANopen	CANlink	EtherCAT	Profinet	Frequency division output	STO ^[1]	DI/DO	AI/AO
630P	○	○	-	-	-	-	○	-	7DI/5DO	-
630N	-	-	-	-	○	-	-	*	5DI/2DO	-

Note:[1]STO function is selectable for 630N

18-bit absolute encoder and accurate control

- 18-bit absolute encoder with 4.94 arcseconds resolution, 262,144 PPR, and absolute position tracking up to 65,535 turns.
- The encoder provides reliable performance with a seismic rating of up to 10G and temperature resistance up to 105°C.
- Over 3 years operating life of encoder battery, which can be directly attached to the servo drive.

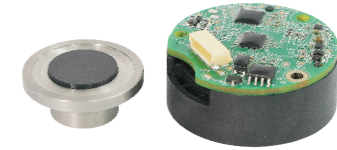

Simple one-click tuning method

- By using keyboard shortcuts or "Position JOG and Auto-tuning" function on the background software. All you need to do is make simple settings to automatically adjust the load inertia ratio, gain, and resonance parameters, thereby maximizing the performance of the servo.

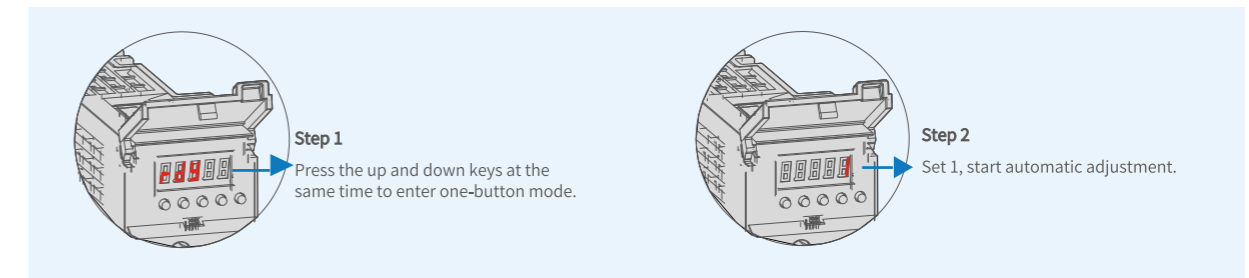

Precise Synchronization

- Applicable to printing machines, engraving and milling machines, die - cutting machines, sanitary equipment production lines, etc.
- Through precise adjustment of EtherCAT distributed clock, it supports 300 nodes within a distance of 120m, with a synchronization error of 15ns and a synchronization jitter of ±20ns.

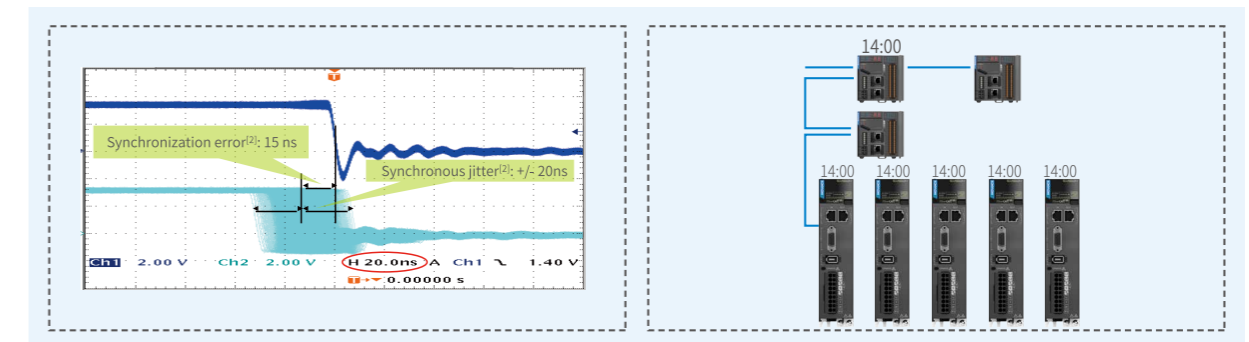

Note: Synchronization error refers to the time deviation between any two nodes when receiving synchronization signals; Synchronization jitter refers to the variation error in the interval time of synchronization signals.

Compact Size, Enhanced Power Density

- With innovative design and next-gen power devices, the SV630 servo drive achieves a 30% volume reduction.

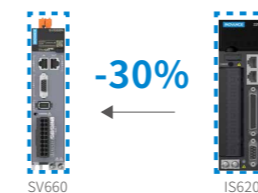

		SV660	IS620
400W	Width (mm)	40	50
	Height (mm)	160	160
	Depth (mm)	150	173
	Volume (L)	0.96	1.38
	Compare with IS620		-30%

Electrical Specifications

Single-phase 220V drive

Item	SIZE-A	SIZE-B	SIZE-C	SIZE-D
Servo Drive Model	S1R6	S2R8	S5R5	S7R6
Drive Power (kW)	0.2	0.4	0.75	1.0
Continuous output current (Arms)	1.6	2.8	5.5	7.6
Max. output current (Arms)	5.8	10.1	16.9	23.0
Main circuit power supply	Single-phase 200 V AC-240 V AC, -10% to +10%, 50 Hz/60 Hz			
Control circuit power supply	Powered up by the bus, no need for separate power supply		Single-phase 200 V AC-240 V AC, -10% to +10%, 50 Hz/60 Hz	
Braking resistor	All series support both built-in and external brake resistors; only Size A does not come with built-in resistors as standard.			



Three-phase 220V drive

Item	SIZE-C	SIZE-D
Servo Drive Model	S7R6	S012
Drive Power (kW)	1.0	1.5
Continuous output current (Arms)	7.6	11.6
Max. output current (Arms)	23.0	32.0
Main circuit power supply	3-phase 200 V AC-240 V AC, -10% to +10%, 50 Hz/60 Hz	
Control circuit power supply	Single-phase 200 V AC-240 V AC, -10% to +10%, 50 Hz/60 Hz	
Braking resistor	Built-in and external resistor is supported	

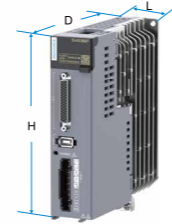

Three-phase 400V drive

Item	SIZE-C	SIZE-D	SIZE-E
Servo Drive Model	T3R5	T5R4	T8R4
Drive Power (kW)	1.0	1.5	2.0
Continuous output current (Arms)	3.5	5.4	8.4
Max. output current (Arms)	11.0	14.0	20.0
Main circuit power supply	3-phase 380 V AC-480 V AC, -10% to +10%, 50 Hz/60 Hz		
Control circuit power supply	Single-phase 380 V AC-480 V AC, -10% to +10%, 50 Hz/60 Hz		
Braking resistor	All series support both built-in and external brake resistors		

Dimensions

SV630P	SV630N	Frame size	L (mm)	H (mm)	D (mm)	Mounting hole	Weight (kg)
		SIZE A	40	170	150	2-M4	0.8
		SIZE B	50	170	173	2-M4	1.0
		SIZE C	55±1	170	173±1	2-M4	1.3
		SIZE D	80±1	170	183	3-M4	1.8
		SIZE E	90	250	230	4-M4	3.6

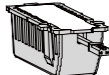
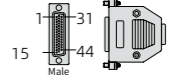
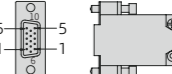
Accessories

Description	Model	Outline Drawing
Battery box kit (without battery)	S6-C4A-NB	
Battery kit	S6-C4A	
CN1 connector (DB44) (for SV630P)	S6-C8	
CN1 connector (DB15) (for SV630N)	S6-C6	
PC communication cable	S6-L-T00-3.0	

MS1-R Series

(High Performance Servo Motor)



Product Feature

- Power from 0.05kW to 7.5kW with 6 types of frame size
- Compact dimensions with more power per space
- Optimized characteristics max. speed 7000rpm
- Highest energy efficiency equivalent to IE5 rating
- Options: 18/23/26bit multi-turn encoder
- Perfect low torque, low speed ripple and high accuracy
- Battery-less multi-turn encoder motor available

6 Advanced technical design Highlights



- Small size**
 Smaller footprint with torque output unchanged, max. reduction of length reaching **29%**
Dimensions of mounting interfaces **Compatible** with MS1-Z series motors
- High stiffness**
 Stiffness of typical models **increased by five levels**
- Low temperature rise**
 Optimized electromagnetic circuit to reduce temperature rise
 Flange size 60 & 80: Temperature rise reduced by **20K** compared with previous motors
- High energy-saving performance**
 550 W to 7.5 kW motors compliant with energy efficiency equal to **IE5 standard**
- Full range of motors**
Ultra-low inertia available for motors with flange size 60/80 to better fit applications requiring quick jog control;
 220 V models available for motors with flange size 100/130/180;
 Regular **26-bit multi-turn absolute encoder** and **functional safety-type 26-bit multi-turn absolute encoder** available for applications requiring high precision
- High speed**
 Max. speed of MS1H1 and MS1H4 motors with flange size 40/60/80 increased from 6000 rpm to **7000 rpm**
 Max. speed of MS1H2 motors increased from 5000 rpm to **6000 rpm**
 Max. speed of MS1H3 motors (flange size 130/180) increased from 3000 rpm to **4500 rpm**
 Note: The preceding speeds are for motors with 23-bit or 26-bit encoders.

Battery-less Multi-turn Encoder Servo System

Cost and Time Saving | Maintenance-Free | Environmental Protection

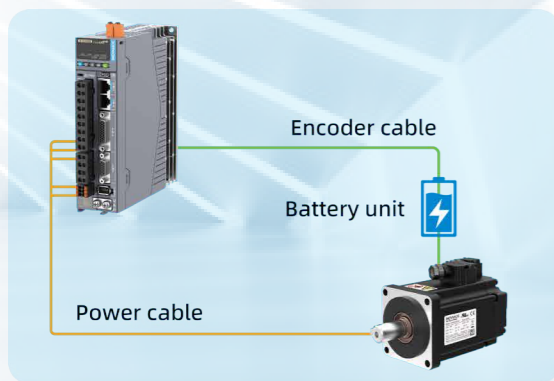

Encoder with battery

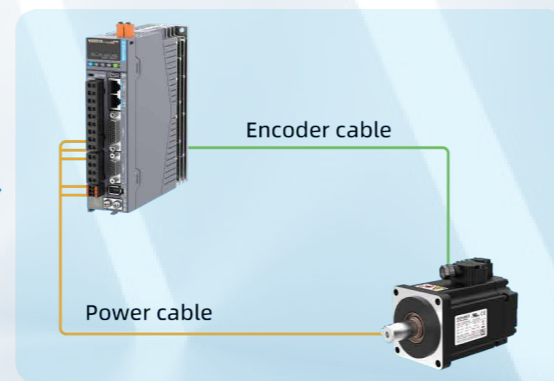

Battery-less encoder

Specifications

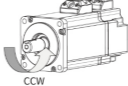
Item	Description
Duty type	S1 (Continuous duty)
Vibration class	V15 ^[1]
Insulation resistance	500 VDC, above 10 MΩ
Ambient temperature	0°C to 40°C (non-frozen) (See the derating curve for temperatures above 40°C.)
Ambient humidity	20% to 80% (without condensation)
Storage environment	Observe the following environment requirements for storing a de-energized motor: ·Storage temperature: -20° C to +60° C (non-frozen) ·Storage humidity: 20% to 80% RH (without condensation)
Excitation mode	Permanent magnet
Installation mode	Flange type
Insulation class	F (155°C)
Insulation voltage	1 min for 1500 VAC (220 V class); 1 min for 1800 VAC (380 V class)
IP rating of enclosure	IP67 (excluding shaft opening and connectors of flying lead type motors)
Ambient humidity	20% to 80%RH (without condensation)
Direction of rotation	Rotating counterclockwise when viewed from the driving end side with forward run commands 
Vibration resistance ^{[2][4]}	49 m/s ² (Flange face as standard)
Shock resistance ^{[3][4]}	490 m/s ² (Flange face as standard); Number of shocks: Two
Altitude	Derating is required only for altitudes above 1000 m.
Certification	CE/UKCA/UL/EAC/RoHS

Note: [1] Vibration level V15 represents the vibration amplitude of the servo motor is lower than 15 μm during operation at rated speed.
[2] The vertical, side-to-side, and front-to-back vibration resistance in three directions when the motor is mounted with the shaft in a horizontal position is given in the above table.
[3] The shock resistance for shock in the vertical direction when the motor is mounted with the shaft in a horizontal position is given in the above table.
[4] Do not operate the system at a fixed frequency because exceeding the allowable vibration value can damage the system.



Battery-less Design

- Simplify the wiring inside the control cabinet
- Save equipment wiring time
- Overcomes air & sea transportation challenges for customers



Maintenance-free

- Eliminates home position calibration caused by battery replacement
- No risk of power cable disconnection due to battery removal
- Lifetime maintenance-free - Improved reliability and ease of use



Environmental Protection

- No need to manage battery inventory anymore
- Reduces battery usage to minimize environmental impact

ATEX+CCC Dual-standard certified

Explosion-Protected motor



- II 2 G Ex db IIC T5 Gb (explosive gas atmospheres)
- II 2 D Ex tb IIIC T100°C Db (combustible dust atmospheres)



- TÜV 25 ATEX 9306 X
- IECEx TUR 25.0046 X



- IEC System for Certification to Standards relating to Equipment for use in Explosive Atmospheres



- CCC 2024312301007305



- Will be done in Q1 2026



High Reliability

- Motor with PTC thermal resistance protection
- IP66/IP67

Easy to connection

- Terminal box can turning 360°
- Fast connection terminal connectors



Naming Description

MS1 H4 - 20B 30C B - A3 3 1 R -INT- EX d T5

① ② ③ ④ ⑤ ⑥ ⑦ ⑧ ⑨ ⑩ ⑪

① MS1 series servo motor	④ Rated speed (rpm) One letter and two digits B: x 10 C: x 100 Example: 30C indicates 3,000 rpm	⑧ Brake, reducer, oil seal 1: With oil seal but no brake 4: With oil seal and brake
② Inertia and capacity H3: Medium inertia, medium capacity H4: Medium inertia, small capacity	⑤ Voltage class (V) B:220 D:380	⑨ Motor series R series
③ Rated power (W) One letter and two digits B:x10 C: x 100 Example, 20B indicates 200 W.	⑥ Encoder type D3: 23-bit battery-less multi-turn absolute encoder A3: 23-bit multi-turn absolute encoder	⑩ Model type INT International
	⑦ Shaft connection mode 3: Solid shaft, with key and threaded hole	⑪ Explosion protection level EX d T5: II 2 G Ex db IIC T5 Gb II 2 D Ex tb IIIC T100°C Db EX d T4: II 2 G Ex db IIC T4 Gb II 2 D Ex tb IIIC T135°C Db

ATEX/IECEx gas explosion protection certification

II 2 G Ex db IIC T5/T4 Gb

① ② ③ ④ ⑤ ⑥ ⑦ ⑧

① Equipment group II: Surface	④ Ex marking Ex: The equipment fulfils valid EN-standards, confirmed by an accredited Test Lab	⑦ Maximum surface temperature of the motor ^[1] T5: Surface temperature of the motor ≤ 100°C T4: Surface temperature of the motor ≤ 135°C
② Category of equipment 2: For use in areas in which explosive atmospheres are likely to occur	⑤ Type of ignition protection db: Flameproof enclosure (Safety: db > ec > ic...)	⑧ Equipment protection level (EPL) Gb: High level, suitable for use in explosive gas environments of Zone 1 (or Gc Zone 2)
③ Potentially explosive areas G: Areas with explosive gas	⑥ Explosion proof gas IIC: Hydrogen, Acetylene (Can cover IIB and IIA group)	

Note: [1] The lower the maximum surface temperature of the motor, the safer it is in operation.

ATEX/IECEx dust explosion protection certification

II 2 D Ex Tb IIIC T100°C /T135°C Db

① ② ③ ④ ⑤ ⑥ ⑦ ⑧

① Equipment group II: Surface	④ Ex marking Ex: The equipment fulfils valid EN-standards, confirmed by an accredited Test Lab	⑦ Maximum surface temperature of the motor ^[1] T100°C : Surface temperature of the motor ≤ 100°C T135°C : Surface temperature of the motor ≤ 135°C
② Protection level 2: High level of protection	⑤ Type of ignition protection tb: Protection by enclosure (Safety: tb > ic...)	⑧ Equipment protection level (EPL) Db: High level of protection
③ Potentially explosive areas D: Areas with explosive dust	⑥ Explosion proof dust IIIC: Permitted dust category, conductive dust (Also fulfill IIIA and IIB)	

Note: [1] The lower the maximum surface temperature of the motor, the safer it is in operation.

Selection chart

⚡ ATEX: II 2 G Ex db IIC T5 Gb, II 2 D Ex tb IIIC T100°C Db

⚡ CCC: Ex db IIC T5 Gb, Ex tb IIIC T100°C Db

Servo motor			Recommended drive
Model ^[1]	Frame size (mm)	Capacity (kW)	Model
MS1H4-20B30CB-**3*R-INT-EX d T5	60	0.2	SV680*S1R6I-GINT / IS810*S(D)3R5INT
MS1H4-40B30CB-**3*R-INT-EX d T5		0.4	SV680*S2R8I-GINT / IS810*S(D)3R5INT
MS1H4-55B30CB-**31R-INT-EX d T5	80	0.55	SV680*S5R5I-GINT / IS810*S(D)5R4INT
MS1H4-75B30CB-**3*R-INT-EX d T5		0.75	
MS1H4-90B30CB-**3*R-INT-EX d T5		0.9	SV680*S7R6I-GINT / IS810*S(D)8R4INT
MS1H3-85B15CD-**3*R-INT-EX d T5	130	0.85	SV680*T3R5I-GINT / IS810*S(D)3R5INT
MS1H3-13C15CD-**3*R-INT-EX d T5		1.3	SV680*T5R4I-GINT / IS810*S(D)5R4INT
MS1H3-16C15CD-**3*R-INT-EX d T5		1.6	SV680*T8R4I-GINT / IS810*S(D)8R4INT
MS1H3-29C15CD-**3*R-INT-EX d T5	180	2.9	SV680*T012I-GINT / IS810*S(D)012INT
MS1H3-37C15CD-**3*R-INT-EX d T5		3.7	SV680*T017I-GINT / IS810*S(D)017INT
MS1H3-45C15CD-**3*R-INT-EX d T5		4.5	SV680*T026I-GINT / IS810*S(D)026INT

Note: [1] The asterisk (**) indicates an optional for encoder type of A3 or D3, the (*) indicates an optional for motor with brake(code:4) or without brake(code:1).

⚡ ATEX: II 2 G Ex db IIC T4 Gb, II 2 D Ex tb IIIC T135°C Db

⚡ CCC: Ex db IIC T4 Gb, Ex tb IIIC T135°C Db

Servo motor			Recommended drive
Model ^[1]	Frame size(mm)	Capacity (kW)	Model
MS1H4-20B30CB-**3*R-INT-EX d T4	60	0.2	SV680*S1R6I-GINT/IS810*S(D)3R5INT
MS1H4-40B30CB-**3*R-INT-EX d T4		0.4	SV680*S2R8I-GINT/IS810*S(D)3R5INT
MS1H4-55B30CB-**31R-INT-EX d T4	80	0.55	SV680*S5R5I-GINT/IS810*S(D)5R4INT
MS1H4-75B30CB-**3*R-INT-EX d T4		0.75	
MS1H4-10C30CB-**3*R-INT-EX d T4		1.0	SV680*S7R6I-GINT/IS810*S(D)8R4INT
MS1H3-85B15CD-**3*R-INT-EX d T4	130	0.85	SV680*T3R5I-GINT/IS810*S(D)3R5INT
MS1H3-13C15CD-**3*R-INT-EX d T4		1.3	SV680*T5R4I-GINT/IS810*S(D)5R4INT
MS1H3-18C15CD-**3*R-INT-EX d T4		1.8	SV680*T8R4I-GINT/IS810*S(D)8R4INT
MS1H3-29C15CD-**3*R-INT-EX d T4	180	2.9	SV680*T012I-GINT/IS810*S(D)012INT
MS1H3-44C15CD-**3*R-INT-EX d T4		4.4	SV680*T017I-GINT/IS810*S(D)017INT
MS1H3-55C15CD-**3*R-INT-EX d T4		5.5	SV680*T021I-GINT/IS810*S(D)021INT
MS1H3-75C15CD-**3*R-INT-EX d T4		7.5	SV680*T026I-GINT/IS810*S(D)026INT

Note: [1] The asterisk (**) indicates an optional for encoder type of A3 or D3, the (*) indicates an optional for motor with brake(code:4) or without brake(code:1).

⚠ When use other types of drive, the PTC temperature control module must be used in conjunction with it. Otherwise, if the motor temperature cannot be monitored, there is a risk of explosion.

Specifications

⚡ ATEX: II 2 G Ex db IIC T5 Gb, II 2 D Ex tb IIIC T100°C Db

⚡ CCC: Ex db IIC T5 Gb, Ex tb IIIC T100°C Db

Motor model ^[1]	Frame size (mm)	Rated power (kW)	Voltage (V)	Rated torque (N·m)	Max. torque (N·m)	Rated current (A)	Max. current (A)	Rated speed (rpm)	Max. speed (rpm)	Torque coefficient (N·m/A)	Moment of inertia (kg·cm ²)
MS1H4-20B30CB-**3*R-INT-EX d T5	60	0.2	220	0.64	2.24	1.3	5.3	3000	7000	0.46	0.22±10% (0.23±10%)
MS1H4-40B30CB-**3*R-INT-EX d T5		0.4	220	1.27	4.45	2.4	9.2	3000	7000	0.53	0.44±10% (0.45±10%)
MS1H4-55B30CB-**31R-INT-EX d T5	80	0.55	220	1.75	6.13	3.3	13.2	3000	7000	0.49	1.16±10%
MS1H4-75B30CB-**3*R-INT-EX d T5		0.75	220	2.39	8.37	4.4	16.9	3000	7000	0.58	1.52±10% (1.55±10%)
MS1H4-90B30CB-**3*R-INT-EX d T5		0.9	220	2.86	9.54	5.85	24	3000	7000	0.46	1.96±10% (1.99±10%)
MS1H3-85B15CD-**3*R-INT-EX d T5	130	0.85	380	5.39	13.5	3.5	8.5	1500	4500	1.84	13.56±10% (15.8±10%)
MS1H3-13C15CD-**3*R-INT-EX d T5		1.3	380	8.34	20.85	5.1	12.6	1500	4500	1.85	19.25±10% (21.5±10%)
MS1H3-16C15CD-**3*R-INT-EX d T5		1.6	380	10.4	28.75	6.08	17.7	1500	4500	1.87	24.9±10% (27.2±10%)
MS1H3-29C15CD-**3*R-INT-EX d T5		2.9	380	18.6	46.5	10.5	29.75	1500	4500	1.94	44.7±10% (52.35±10%)
MS1H3-37C15CD-**3*R-INT-EX d T5	180	3.7	380	24.2	71.1	13.6	42	1500	4500	1.96	64.9±10% (72.55±10%)
MS1H3-45C15CD-**3*R-INT-EX d T5		4.5	380	29	119	15	65	1500	4500	2.13	127.5±10% (135.15±10%)

Note: [1] The asterisk (**) indicates an optional for encoder type of A3 or D3, the (*) indicates an optional for motor with brake(code:4) or without brake(code:1).

Specifications

‡ ATEX: II 2 G Ex db IIC T4 Gb, II 2 D Ex tb IIIC T135°C Db

‡ CCC: Ex db IIC T4 Gb, Ex tb IIIC T135°C Db

Motor model [1]	Frame size (mm)	Rated power (kW)	Voltage (V)	Rated torque (N·m)	Max. torque (N·m)	Rated current (A)	Max. current (A)	Rated speed (rpm)	Max. speed (rpm)	Torque coefficient (N·m/A)	Moment of inertia (kg·cm ²)
MS1H4-20B30CB- **3*R-INT-EX d T4	60	0.2	220	0.64	2.24	1.3	5.3	3000	7000	0.46	0.22±10% (0.23±10%)
MS1H4-40B30CB- **3*R-INT-EX d T4		0.4	220	1.27	4.45	2.4	9.2	3000	7000	0.53	0.44±10% (0.45±10%)
MS1H4-55B30CB- **31R-INT-EX d T4	80	0.55	220	1.75	6.13	3.3	13.2	3000	7000	0.49	1.16±10%
MS1H4-75B30CB- **3*R-INT-EX d T4		0.75	220	2.39	8.37	4.4	16.9	3000	7000	0.58	1.52±10% (1.55±10%)
MS1H4-10C30CB- **3*R-INT-EX d T4		1.0	220	3.18	9.54	6.5	24	3000	7000	0.46	1.96±10% (1.99±10%)
MS1H3-85B15CD- **3*R-INT-EX d T4	130	0.85	380	5.39	13.5	3.5	8.5	1500	4500	1.84	13.56±10% (15.8±10%)
MS1H3-13C15CD- T33*R-EX d T4		1.3	380	8.34	20.85	5.1	12.6	1500	4500	1.85	19.25±10% (21.5±10%)
MS1H3-18C15CD- **3*R-INT-EX d T4		1.8	380	11.5	28.75	6.75	17.7	1500	4500	1.87	24.9±10% (27.2±10%)
MS1H3-29C15CD- **3*R-INT-EX d T4	180	2.9	380	18.6	46.5	10.5	29.75	1500	4500	1.94	44.7±10% (52.35±10%)
MS1H3-44C15CD- **3*R-INT-EX d T4		4.4	380	28.4	71.1	16	42	1500	4500	1.96	64.9±10% (72.55±10%)
MS1H3-55C15CD- **3*R-INT-EX d T4		5.5	380	35	87.6	20.7	52	1500	4500	1.92	86.9±10% (94.55±10%)
MS1H3-75C15CD- **3*R-INT-EX d T4		7.5	380	48	119	25	65	1500	4500	2.13	127.5±10% (135.15±10%)

Note: [1] The asterisk (**) indicates an optional for encoder type of A3 or D3, the (*) indicates an optional for motor with brake(code:4) or without brake(code:1).

S6-L-INT Series

Servo Connection Cable



Compliance with standards



High reliability

- Power and encoder cable with shield to enhance EMC characteristic.
- Degree of protection IP67 (motor side when mated and locked).
- Number of bending cycles for flexible cable ≥ 10 000 000.

Easy to use

- Easy to plug-in.
- Options for terminal-type connector with front or rear outlet.
- Circular metal connector can adjust the cable routing by 360°.

Harsh resistance environment

- Oil resistance and flame-retardant meet approvals such as UL and CE
- 10g Strength of vibration resistance

Naming Description

Power cable model

S6-L-M 0 0 1 - 3.0 - T - INT
 ① ② ③ ④ ⑤ ⑥ ⑦

① Servo system power cable B: With brake M: Without brake	③ Applicable power of the motor 0: Frame sizes 40/60/80 1: Frame sizes 100/130/180 2: Frame size 180 (motors of 4.4kW and above)	⑤ Cable length (m) 3.0: 3 5.0: 5 10.0: 10
② Connector type at drive side 0: U-shaped cable lug 1: Pin-shaped cable lug	④ Connector type at motor side 1: 9-core aviation connector 2: 6-core aviation connector 7: Specified connector for FS 40/60/80mm motor (front outlet) 8: Specified connector for FS 40/60/80mm motor (rear outlet)	⑥ Special requirements Null: Non-flexible T: Flexible cables ≥ 10 million bendings
		⑦ Version INT: Global version

Encoder cable model

S6-L-P 1 2 1 - 3.0 - T - INT
 ① ② ③ ④ ⑤ ⑥ ⑦

① Servo system encoder cable	④ Connector type at motor sider 1: 9-core aviation connector 4: Specified connector for FS 40/60/80mm motor (front outlet) 5: Specified connector for FS 40/60/80mm motor (rear outlet)	⑥ Special requirements Null: Non-flexible T: Flexible cables ≥ 10 million bendings
② Connector type at drive side 1: 1394 Connector (6pin plug)		
③ Encoder 1: Communication-type incremental encoder 2: Multi-turn absolute encoder	⑤ Cable length(m) 3.0: 3m 5.0: 5m 10.0: 10m	⑦ Version INT: Global version

Cable Selection

Power cable

Motor Model	Cable Name	Cable Model	Cable Length (mm)	Dimension Drawing
MS1H1/ MS1H4 terminal- type motor	Without brake (Front outlet)	S6-L-M107-3.0 (-T) -INT	3000	
		S6-L-M107-5.0 (-T) -INT	5000	
		S6-L-M107-10.0 (-T) -INT	10000	
	With brake (Front outlet)	S6-L-B107-3.0 (-T) -INT	3000	
		S6-L-B107-5.0 (-T) -INT	5000	
		S6-L-B107-10.0 (-T) -INT	10000	
MS1H2 motors of 3 kW and below/ MS1H3 motors of 1.8 kW and below	Without brake (Rear outlet)	S6-L-M108-3.0 (-T) -INT	3000	
		S6-L-M108-5.0 (-T) -INT	5000	
		S6-L-M108-10.0 (-T) -INT	10000	
	With brake (Rear outlet)	S6-L-B108-3.0 (-T) -INT	3000	
		S6-L-B108-5.0 (-T) -INT	5000	
		S6-L-B108-10.0 (-T) -INT	10000	
MS1H2 motors of 3 kW and below/ MS1H3 motors of 1.8 kW and below	Without brake	S6-L-M111-3.0 (-T) -INT	3000	
		S6-L-M111-5.0 (-T) -INT	5000	
		S6-L-M111-10.0 (-T) -INT	10000	
	With brake	S6-L-B111-3.0 (-T) -INT	3000	
		S6-L-B111-5.0 (-T) -INT	5000	
		S6-L-B111-10.0 (-T) -INT	10000	

Cable Selection

Power cable

Motor Model	Cable Name	Cable Model	Cable Length (mm)	Dimension Drawing
MS1H2 motors of 4 kW/5 kW	Without brake	S6-L-M011-3.0 (-T) -INT	3000	
		S6-L-M011-5.0 (-T) -INT	5000	
		S6-L-M011-10.0 (-T) -INT	10000	
	With brake	S6-L-B011-3.0 (-T) -INT	3000	
		S6-L-B011-5.0 (-T) -INT	5000	
		S6-L-B011-10.0 (-T) -INT	10000	
MS1H3 motors of 2.9 kW	Without brake	S6-L-M112-3.0 (-T) -INT	3000	
		S6-L-M112-5.0 (-T) -INT	5000	
		S6-L-M112-10.0 (-T) -INT	10000	
	With brake	S6-L-B112-3.0 (-T) -INT	3000	
		S6-L-B112-5.0 (-T) -INT	5000	
		S6-L-B112-10.0 (-T) -INT	10000	
MS1H3 motors of 4.4 kW and above	Without brake	S6-L-M022-3.0 (-T) -INT	3000	
		S6-L-M022-5.0 (-T) -INT	5000	
		S6-L-M022-10.0 (-T) -INT	10000	
	With brake	S6-L-B022-3.0 (-T) -INT	3000	
		S6-L-B022-5.0 (-T) -INT	5000	
		S6-L-B022-10.0 (-T) -INT	10000	

Note:

- [1] For more information on cables, see section Cable Specifications and Models in the hardware guide of the servo drive.
- [2] Motor with power 50w, the power cables must select the rear outlet model as shown on the right.
- [3] INT version cables comply with CE and UL certifications.
- [4] INT version cables are default equipped with Oil-Resistant and Shielded cables.
- [5] Power cables of INT version are colored orange.

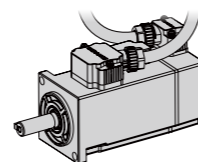

Cable Selection

Encoder Cable

Motor Model	Cable Name	Cable Model	Cable Length (mm)	Dimension Drawing	
MS1H1 / MS1H4 terminal-type motors	Front outlet	Single-turn absolute encoder	S6-L-P114-3.0 (-T) -INT	3000	
			S6-L-P114-5.0 (-T) -INT	5000	
			S6-L-P114-10.0 (-T) -INT	10000	
	Multi-turn absolute encoder	S6-L-P124-3.0 (-T) -INT	3000		
		S6-L-P124-5.0 (-T) -INT	5000		
		S6-L-P124-10.0 (-T) -INT	10000		
Rear outlet	Single-turn absolute encoder	S6-L-P115-3.0 (-T) -INT	3000		
			S6-L-P115-5.0 (-T) -INT		5000
			S6-L-P115-10.0 (-T) -INT		10000
	Multi-turn absolute encoder	S6-L-P125-3.0 (-T) -INT	3000		
		S6-L-P125-5.0 (-T) -INT	5000		
		S6-L-P125-10.0 (-T) -INT	10000		
MS1H2 / MS1H3 motors	Single-turn absolute encoder	S6-L-P111-3.0 (-T) -INT	3000		
			S6-L-P111-5.0 (-T) -INT		5000
			S6-L-P111-10.0 (-T) -INT		10000
	Multi-turn absolute encoder	S6-L-P121-3.0 (-T) -INT	3000		
		S6-L-P121-5.0 (-T) -INT	5000		
		S6-L-P121-10.0 (-T) -INT	10000		

Note:

- [1] For more information on cables, see section Cable Specifications and Models in the hardware guide of the servo drive.
- [3] INT version cables comply with CE and UL certifications.
- [4] INT version cables are default equipped with Oil-Resistant and Shielded cables.
- [5] Encoder cables of INT version are colored green .

SV680 Series-Selection

Voltage Class	Servo Motor									Servo Drive				Cable ^[1]				Battery Box	
	MS1 motor model ^[2]	Rated power (W)	Rotor inertia (kg·cm ²)	Rated speed (rpm)	Max. speed (rpm)	Frame size (mm)	Rated torque (N·m)	Max. torque (N·m)	Motor Weight (kg)	SV680 drive model	Rated current (A)	Max. current (A)	Size	Drive Weight (kg)	Power Cable		Encoder cable		
															Without brake	With brake	Single-turn absolute encoder		Multi-turn absolute encoder
1/3PH 220V	MS1H1-05B30CB-A6/S63*R-INT ^[4]	50	0.018	3000	7000	40×40	0.16	0.56	0.26	SV680*S1R6I/S-*INT	1.6	5.8	A	0.96/1.11	S6-L-M107-*(-T)-INT Rear outlet: S6-L-M108-*(-T)-INT	S6-L-B107-*(-T)-INT Rear outlet: S6-L-B108-*(-T)-INT	S6-L-P114-*(-T)-INT Rear outlet: S6-L-P115-*(-T)-INT	S6-L-P124-*(-T)-INT Rear outlet: S6-L-P125-*(-T)-INT	
	MS1H1-10B30CB-A6/S63*R-INT ^[4]	100	0.0316	3000	7000	40×40	0.32	1.12	0.35	SV680*S1R6I/S-*INT	1.6	5.8	A	0.96/1.11					
	MS1H1-20B30CB-A6/S6/V63*R-INT	200	0.094	3000	7000	60×60	0.64	2.24	0.8	SV680*S1R6I/S-*INT	1.6	5.8	A	0.96/1.11					
	MS1H1-40B30CB-A6/S6/V63*R-INT	400	0.145	3000	7000	60×60	1.27	4.45	1.11	SV680*S2R8I/S-*INT	2.8	10.1	A	0.96/1.11					
	MS1H1-55B30CB-A6/S6/V63*R-INT ^[3]	550	0.55	3000	7000	80×80	1.75	6.13	1.88	SV680*S5R5I/S-*INT	5.5	16.9	C	1.30/1.45					
	MS1H1-75B30CB-A6/S6/V63*R-INT	750	0.68	3000	7000	80×80	2.39	8.37	2.22	SV680*S5R5I/S-*INT	5.5	16.9	C	1.30/1.45					
	MS1H1-10C30CB-A6/S6/V63*R-INT	1000	0.82	3000	7000	80×80	3.18	11.13	2.61	SV680*S7R6I/S-*INT	7.6	23	C	1.30/1.45					
	MS1H2-10C30CB-A6/S6/V63*R-INT	1000	1.78	3000	6000	100×100	3.18	9.54	3.85	SV680*S7R6I/S-*INT	7.6	23	C	1.30/1.45					
	MS1H2-15C30CB-A6/S6/V63*R-INT	1500	2.35	3000	6000	100×100	4.9	14.7	4.65	SV680*S012I/S-*INT	12	32	D	1.80/1.95					
	MS1H3-85B15CB-A6/S6/V63*R-INT	850	13.56	1500	4500	130×130	5.39	13.5	5.8	SV680*S7R6I/S-*INT	7.6	23	C	1.30/1.45					
	MS1H3-13C15CB-A6/S6/V63*R-INT	1300	19.25	1500	4500	130×130	8.34	20.85	7.1	SV680*S012I/S-*INT	12	32	D	1.80/1.95					
	MS1H4-05B30CB-A6/S63*R-INT ^[4]	50	0.038	3000	7000	40×40	0.16	0.56	0.24	SV680*S1R6I/S-*INT	1.6	5.8	A	0.96/1.11					
	MS1H4-10B30CB-A6/S63*R-INT ^[4]	100	0.072	3000	7000	40×40	0.32	1.12	0.32	SV680*S1R6I/S-*INT	1.6	5.8	A	0.96/1.11					
	MS1H4-20B30CB-A6/S6/V63*R-INT	200	0.22	3000	7000	60×60	0.64	2.24	0.78	SV680*S1R6I/S-*INT	1.6	5.8	A	0.96/1.11					
	MS1H4-40B30CB-A6/S6/V63*R-INT	400	0.43	3000	7000	60×60	1.27	4.45	1.11	SV680*S2R8I/S-*INT	2.8	10.1	A	0.96/1.11					
	MS1H4-55B30CB-A6/S6/V63*R-INT ^[3]	550	1.12	3000	7000	80×80	1.75	6.13	1.85	SV680*S5R5I/S-*INT	5.5	16.9	C	1.30/1.45					
MS1H4-75B30CB-A6/S6/V63*R-INT	750	1.46	3000	7000	80×80	2.39	8.37	2.18	SV680*S5R5I/S-*INT	5.5	16.9	C	1.30/1.45						
MS1H4-10C30CB-A6/S6/V63*R-INT	1000	1.87	3000	7000	80×80	3.18	11.13	2.55	SV680*S7R6I/S-*INT	7.6	23	C	1.30/1.45						
3PH 220V	MS1H2-20C30CB-A6/S6/V63*R-INT	2000	2.92	3000	6000	100×100	6.36	19.1	5.5	SV680*S018I/S-*INT	18	45	E	3.60/3.75	S6-L-M111-*(-T)-INT	S6-L-B111-*(-T)-INT	S6-L-P111-*(-T)-INT	S6-L-P121-*(-T)-INT	
	MS1H2-25C30CB-A6/S6/V63*R-INT	2500	3.49	3000	6000	100×100	7.96	23.9	6.3	SV680*S022I/S-*INT	22	55	E	3.60/3.75					
	MS1H2-30C30CB-A6/S6/V63*R-INT	3000	6.4	3000	6000	130×130	9.8	24.5	10	SV680*S022I/S-*INT	22	55	E	3.60/3.75					
	MS1H2-40C30CB-A6/S6/V63*R-INT	4000	9	3000	6000	130×130	12.6	31.5	13.2	SV680*S027I/S-*INT	27	67.5	E	3.60/3.75					
	MS1H2-50C30CB-A6/S6/V63*R-INT	5000	11.6	3000	6000	130×130	15.8	39.5	16.35	SV680*S027I/S-*INT	27	67.5	E	3.60/3.75					
	MS1H3-18C15CB-A6/S6/V63*R-INT	1800	24.9	1500	4500	130×130	11.5	28.75	8.5	SV680*S018I/S-*INT	18	45	E	3.60/3.75					
	MS1H3-29C15CB-A6/S6/V63*R-INT	2900	44.7	1500	4500	180×180	18.6	46.5	13.8	SV680*S022I/S-*INT	22	55	E	3.60/3.75					
MS1H3-44C15CB-A6/S6/V63*R-INT	4400	64.9	1500	4500	180×180	28.4	71.1	17.4	SV680*S027I/S-*INT	27	67.5	E	3.60/3.75						
3PH 400V	MS1H2-10C30CD-A6/S6/V63*R-INT	1000	1.78	3000	6000	100×100	3.18	9.54	3.85	SV680*T3R5I/S-*INT	3.5	11	C	1.30/1.45	S6-L-M111-*(-T)-INT	S6-L-B111-*(-T)-INT	S6-L-P111-*(-T)-INT	S6-L-P121-*(-T)-INT	
	MS1H2-15C30CD-A6/S6/V63*R-INT	1500	2.35	3000	6000	100×100	4.9	14.7	4.65	SV680*T5R4I/S-*INT	5.4	14	C	1.30/1.45					
	MS1H2-20C30CD-A6/S6/V63*R-INT	2000	2.92	3000	6000	100×100	6.36	19.1	5.5	SV680*T8R4I/S-*INT	8.4	20	D	1.80/1.95					
	MS1H2-25C30CD-A6/S6/V63*R-INT	2500	3.49	3000	6000	100×100	7.96	23.9	6.3	SV680*T012I/S-*INT	12	30	D	1.80/1.95					
	MS1H2-30C30CD-A6/S6/V63*R-INT	3000	6.4	3000	6000	130×130	9.8	29.4	10	SV680*T012I/S-*INT	12	30	D	1.80/1.95					
	MS1H2-40C30CD-A6/S6/V63*R-INT	4000	9	3000	6000	130×130	12.6	37.8	13.2	SV680*T017I/S-*INT	17	42.5	E	3.60/3.75					
	MS1H2-50C30CD-A6/S6/V63*R-INT	5000	11.6	3000	6000	130×130	15.8	47.4	16.35	SV680*T021I/S-*INT	21	52.5	E	3.60/3.75					
	MS1H3-85B15CD-A6/S6/V63*R-INT	850	13.56	1500	4500	130×130	5.39	13.5	5.8	SV680*T3R5I/S-*INT	3.5	11	C	1.30/1.45					
	MS1H3-13C15CD-A6/S6/V63*R-INT	1300	19.25	1500	4500	130×130	8.34	20.85	7.1	SV680*T5R4I/S-*INT	5.4	14	C	1.30/1.45					
	MS1H3-18C15CD-A6/S6/V63*R-INT	1800	24.9	1500	4500	130×130	11.5	28.75	8.5	SV680*T8R4I/S-*INT	8.4	20	D	1.80/1.95					
	MS1H3-29C15CD-A6/S6/V63*R-INT	2900	44.7	1500	4500	180×180	18.6	46.5	13.8	SV680*T012I/S-*INT	12	30	D	1.80/1.95					
	MS1H3-44C15CD-A6/S6/V63*R-INT	4400	64.9	1500	4500	180×180	28.4	71.1	17.4	SV680*T017I/S-*INT	17	42.5	E	3.60/3.75					
	MS1H3-55C15CD-A6/S6/V63*R-INT	5500	86.9	1500	4500	180×180	35	87.6	21.7	SV680*T021I/S-*INT	21	52.5	E	3.60/3.75					
MS1H3-75C15CD-A6/S6/V63*R-INT	7500	127.5	1500	4500	180×180	48	119	29	SV680*T026I/S-*INT	26	65	E	3.60/3.75						

Note: [1] For cables, "" refers to cable length, and the standard cable lengths available are 3.0, 5.0, and 10.0 meters
 [2] MS1 A6 motor is applicable to SV680-xxxx-I model (standard type); MS1 S6 motor is applicable to SV680-xxxx-S model (functional safety type); MS1 V6 motor is a battery-less encoder motor, compatible with all models. When the V6 motor is adopted, a battery box is not required.
 [3] Brake option not available.
 [4] The 40 Frame size motor has no V6 models.

SV670 Series-Selection

Voltage Class	Servo Motor									Servo Drive				Cable ^[1]				Battery Box		
	MS1 motor model ^[2]	Rated power (W)	Rotor inertia (kg·cm ²)	Rated speed (rpm)	Max. speed (rpm)	Frame size (mm)	Rated torque (N·m)	Max. torque (N·m)	Motor Weight (kg)	SV670 drive model	Rated current (A)	Max. current (A)	Size	Drive Weight (kg)	Power Cable		Encoder cable			
															Without brake	With brake	Single-turn absolute encoder		Multi-turn absolute encoder	
1/3PH 220V	MS1H1-05B30CB-A33*R-INT ^[4]	50	0.018	3000	7000	40×40	0.16	0.56	0.26	SV670*-S1R6I(-FS)-INT	1.6	5.8	A	0.96	Front outlet: S6-L-M107*(-T)-INT Rear outlet: S6-L-M108*(-T)-INT	Front outlet: S6-L-B107*(-T)-INT Rear outlet: S6-L-B108*(-T)-INT	Front outlet: S6-L-P114*(-T)-INT Rear outlet: S6-L-P115*(-T)-INT	Front outlet: S6-L-P124*(-T)-INT Rear outlet: S6-L-P125*(-T)-INT	S6-C4A S6-C4A-NB	
	MS1H1-10B30CB-A33*R-INT ^[4]	100	0.0316	3000	7000	40×40	0.32	1.12	0.35	SV670*-S1R6I(-FS)-INT	1.6	5.8	A	0.96						
	MS1H1-20B30CB-A3/V33*R-INT	200	0.094	3000	7000	60×60	0.64	2.24	0.8	SV670*-S1R6I(-FS)-INT	1.6	5.8	A	0.96						
	MS1H1-40B30CB-A3/V33*R-INT	400	0.145	3000	7000	60×60	1.27	4.45	1.11	SV670*-S2R8I(-FS)-INT	2.8	10.1	A	0.96						
	MS1H1-55B30CB-A3/V33*R-INT ^[3]	550	0.55	3000	7000	80×80	1.75	6.13	1.88	SV670*-S5R5I(-FS)-INT	5.5	16.9	C	1.3						
	MS1H1-75B30CB-A3/V33*R-INT	750	0.68	3000	7000	80×80	2.39	8.37	2.22	SV670*-S5R5I(-FS)-INT	5.5	16.9	C	1.3						
	MS1H1-10C30CB-A3/V33*R-INT	1000	0.82	3000	7000	80×80	3.18	11.13	2.61	SV670*-S7R6I(-FS)-INT	7.6	23	C	1.3						
	MS1H2-10C30CB-A3/V33*R-INT	1000	1.78	3000	6000	100×100	3.18	9.54	3.85	SV670*-S7R6I(-FS)-INT	7.6	23	C	1.3						
	MS1H2-15C30CB-A3/V33*R-INT	1500	2.35	3000	6000	100×100	4.9	14.7	4.65	SV670*-S012I(-FS)-INT	12	32	D	1.8						
	MS1H3-85B15CB-A3/V33*R-INT	850	13.56	1500	4500	130×130	5.39	13.5	5.8	SV670*-S7R6I(-FS)-INT	7.6	23	C	1.3						
	MS1H3-13C15CB-A3/V33*R-INT	1300	19.25	1500	4500	130×130	8.34	20.85	7.1	SV670*-S012I(-FS)-INT	12	32	D	1.8						
	MS1H4-05B30CB-A33*R-INT ^[4]	50	0.038	3000	7000	40×40	0.16	0.56	0.24	SV670*-S1R6I(-FS)-INT	1.6	5.8	A	0.96	Front outlet: S6-L-M107*(-T)-INT Rear outlet: S6-L-M108*(-T)-INT	Front outlet: S6-L-B107*(-T)-INT Rear outlet: S6-L-B108*(-T)-INT	Front outlet: S6-L-P114*(-T)-INT Rear outlet: S6-L-P115*(-T)-INT	Front outlet: S6-L-P124*(-T)-INT Rear outlet: S6-L-P125*(-T)-INT		
	MS1H4-10B30CB-A33*R-INT ^[4]	100	0.072	3000	7000	40×40	0.32	1.12	0.32	SV670*-S1R6I(-FS)-INT	1.6	5.8	A	0.96						
	MS1H4-20B30CB-A3/V33*R-INT	200	0.22	3000	7000	60×60	0.64	2.24	0.78	SV670*-S1R6I(-FS)-INT	1.6	5.8	A	0.96						
	MS1H4-40B30CB-A3/V33*R-INT	400	0.43	3000	7000	60×60	1.27	4.45	1.11	SV670*-S2R8I(-FS)-INT	2.8	10.1	A	0.96						
	MS1H4-55B30CB-A3/V33*R-INT ^[3]	550	1.12	3000	7000	80×80	1.75	6.13	1.85	SV670*-S5R5I(-FS)-INT	5.5	16.9	C	1.3						
MS1H4-75B30CB-A3/V33*R-INT	750	1.46	3000	7000	80×80	2.39	8.37	2.18	SV670*-S5R5I(-FS)-INT	5.5	16.9	C	1.3							
MS1H4-10C30CB-A3/V33*R-INT	1000	1.87	3000	7000	80×80	3.18	11.13	2.55	SV670*-S7R6I(-FS)-INT	7.6	23	C	1.3							
MS1H2-20C30CB-A3/V33*R-INT	2000	2.92	3000	6000	100×100	6.36	19.1	5.5	SV670*-S018I(-FS)-INT	18	45	E	3.6							
3PH 220V	MS1H2-25C30CB-A3/V33*R-INT	2500	3.49	3000	6000	100×100	7.96	23.9	6.3	SV670*-S022I(-FS)-INT	22	55	E	3.6	S6-L-M111*(-T)-INT	S6-L-B111*(-T)-INT	S6-L-P111*(-T)-INT	S6-L-P121*(-T)-INT		
	MS1H2-30C30CB-A3/V33*R-INT	3000	6.4	3000	6000	130×130	9.8	24.5	10	SV670*-S022I(-FS)-INT	22	55	E	3.6						
	MS1H2-40C30CB-A3/V33*R-INT	4000	9	3000	6000	130×130	12.6	31.5	13.2	SV670*-S027I(-FS)-INT	27	67.5	E	3.6	S6-L-M011*(-T)-INT	S6-L-B011*(-T)-INT				
	MS1H2-50C30CB-A3/V33*R-INT	5000	11.6	3000	6000	130×130	15.8	39.5	16.35	SV670*-S027I(-FS)-INT	27	67.5	E	3.6						
	MS1H3-18C15CB-A3/V33*R-INT	1800	24.9	1500	4500	130×130	11.5	28.75	8.5	SV670*-S012I(-FS)-INT	12	32	D	1.8	S6-L-M111*(-T)-INT	S6-L-B111*(-T)-INT				
	MS1H3-29C15CB-A3/V33*R-INT	2900	44.7	1500	4500	180×180	18.6	46.5	13.8	SV670*-S022I(-FS)-INT	22	55	E	3.6	S6-L-M112*(-T)-INT	S6-L-B112*(-T)-INT				
	MS1H3-44C15CB-A3/V33*R-INT	4400	64.9	1500	4500	180×180	28.4	71.1	17.4	SV670*-S027I(-FS)-INT	27	67.5	E	3.6	S6-L-M022*(-T)-INT	S6-L-B022*(-T)-INT				
3PH 400V	MS1H2-10C30CD-A3/V33*R-INT	1000	1.78	3000	6000	100×100	3.18	9.54	3.85	SV670*-T3R5I(-FS)-INT	3.5	11	C	1.3	S6-L-M111*(-T)-INT	S6-L-B111*(-T)-INT	S6-L-P111*(-T)-INT	S6-L-P121*(-T)-INT		
	MS1H2-15C30CD-A3/V33*R-INT	1500	2.35	3000	6000	100×100	4.9	14.7	4.65	SV670*-T5R4I(-FS)-INT	5.4	14	C	1.3						
	MS1H2-20C30CD-A3/V33*R-INT	2000	2.92	3000	6000	100×100	6.36	19.1	5.5	SV670*-T8R4I(-FS)-INT	8.4	20	D	1.8						
	MS1H2-25C30CD-A3/V33*R-INT	2500	3.49	3000	6000	100×100	7.96	23.9	6.3	SV670*-T012I(-FS)-INT	12	30	D	1.8						
	MS1H2-30C30CD-A3/V33*R-INT	3000	6.4	3000	6000	130×130	9.8	29.4	10	SV670*-T012I(-FS)-INT	12	30	D	1.8						
	MS1H2-40C30CD-A3/V33*R-INT	4000	9	3000	6000	130×130	12.6	37.8	13.2	SV670*-T017I(-FS)-INT	17	42.5	E	3.6					S6-L-M011*(-T)-INT	S6-L-B011*(-T)-INT
	MS1H2-50C30CD-A3/V33*R-INT	5000	11.6	3000	6000	130×130	15.8	47.4	16.35	SV670*-T021I(-FS)-INT	21	52.5	E	3.6						
	MS1H3-85B15CD-A3/V33*R-INT	850	13.56	1500	4500	130×130	5.39	13.5	5.8	SV670*-T3R5I(-FS)-INT	3.5	11	C	1.3	S6-L-M111*(-T)-INT	S6-L-B111*(-T)-INT				
	MS1H3-13C15CD-A3/V33*R-INT	1300	19.25	1500	4500	130×130	8.34	20.85	7.1	SV670*-T5R4I(-FS)-INT	5.4	14	C	1.3						
	MS1H3-18C15CD-A3/V33*R-INT	1800	24.9	1500	4500	130×130	11.5	28.75	8.5	SV670*-T8R4I(-FS)-INT	8.4	20	D	1.8						
	MS1H3-29C15CD-A3/V33*R-INT	2900	44.7	1500	4500	180×180	18.6	46.5	13.8	SV670*-T012I(-FS)-INT	12	30	D	1.8					S6-L-M112*(-T)-INT	S6-L-B112*(-T)-INT
	MS1H3-44C15CD-A3/V33*R-INT	4400	64.9	1500	4500	180×180	28.4	71.1	17.4	SV670*-T017I(-FS)-INT	17	42.5	E	3.6						
MS1H3-55C15CD-A3/V33*R-INT	5500	86.9	1500	4500	180×180	35	87.6	21.7	SV670*-T021I(-FS)-INT	21	52.5	E	3.6	S6-L-M022*(-T)-INT			S6-L-B022*(-T)-INT			
MS1H3-75C15CD-A3/V33*R-INT	7500	127.5	1500	4500	180×180	48	119	29	SV670*-T026I(-FS)-INT	26	65	E	3.6							

Note: [1] For cables, “*” refers to cable length, and the standard cable lengths available are 3.0, 5.0, and 10.0 meters.

[2] MS1 A3 motor is a standard motor; MS1 V3 motor is a battery-less encoder motor.

When the V3 motor is adopted, a battery box is not required.

[3] Brake option not available.

[4] The 40 Frame size motor has no V3 models.

SV660 Series-Selection

Servo Motor										Servo Drive					Cable ^[1]					
Voltage Class	MS1 motor mode ^[2]	Rated power (W)	Rotor inertia (kg·c·m ²)	Rated speed (rpm)	Max. speed (rpm)	Frame size (mm)	Rated torque (N·m)	Max. torque (N·m)	Motor Weight (kg)	SV660 drive model	Rated current (A)	Max. current (A)	Size	Drive Weight (kg)	Power Cable		Encoder cable		Communication cable	Battery Box
															Without brake	With brake	Single-turn absolute encoder	Multi-turn absolute encoder	PC communication cable	
1PH 220V	MS1H1-05B30CB-A33*R-INT ^[4]	50	0.02	3000	7000	40×40	0.16	0.56	0.26	SV660*-S1R6I(-FS)-INT	1.6	5.8	A	0.8	Front outlet: S6-L-M107*(-T)-INT Rear outlet: S6-L-M108*(-T)-INT	Front outlet: S6-L-B107*(-T)-INT Rear outlet: S6-L-B108*(-T)-INT	Front outlet: S6-L-P114*(-T)-INT Rear outlet: S6-L-P115*(-T)-INT	Front outlet: S6-L-P124*(-T)-INT Rear outlet: S6-L-P125*(-T)-INT		
	MS1H1-10B30CB-A33*R-INT ^[4]	100	0.03	3000	7000	40×40	0.32	1.12	0.35	SV660*-S1R6I(-FS)-INT	1.6	5.8	A	0.8						
	MS1H1-20B30CB-A3/V33*R-INT	200	0.09	3000	7000	60×60	0.64	2.24	0.8	SV660*-S1R6I(-FS)-INT	1.6	5.8	A	0.8						
	MS1H1-40B30CB-A3/V33*R-INT	400	0.15	3000	7000	60×60	1.27	4.45	1.11	SV660*-S2R8I(-FS)-INT	2.8	10.1	A	0.8						
	MS1H1-55B30CB-A3/V33*R-INT ^[3]	550	0.55	3000	7000	80×80	1.75	6.13	1.88	SV660*-S5R5I(-FS)-INT	5.5	16.9	B	1						
	MS1H1-75B30CB-A3/V33*R-INT	750	0.68	3000	7000	80×80	2.39	8.37	2.22	SV660*-S5R5I(-FS)-INT	5.5	16.9	B	1						
	MS1H4-05B30CB-A33*R-INT ^[4]	50	0.04	3000	7000	40×40	0.16	0.56	0.24	SV660*-S1R6I(-FS)-INT	1.6	5.8	A	0.8						
	MS1H4-10B30CB-A33*R-INT ^[4]	100	0.07	3000	7000	40×40	0.32	1.12	0.32	SV660*-S1R6I(-FS)-INT	1.6	5.8	A	0.8						
	MS1H4-20B30CB-A3/V33*R-INT	200	0.22	3000	7000	60×60	0.64	2.24	0.78	SV660*-S1R6I(-FS)-INT	1.6	5.8	A	0.8						
	MS1H4-40B30CB-A3/V33*R-INT	400	0.43	3000	7000	60×60	1.27	4.45	1.11	SV660*-S2R8I(-FS)-INT	2.8	10.1	A	0.8						
	MS1H4-55B30CB-A3/V33*R-INT ^[3]	550	1.12	3000	7000	80×80	1.75	6.13	1.85	SV660*-S5R5I(-FS)-INT	5.5	16.9	B	1						
	MS1H4-75B30CB-A3/V33*R-INT	750	1.46	3000	7000	80×80	2.39	8.37	2.18	SV660*-S5R5I(-FS)-INT	5.5	16.9	B	1						
1/3PH 220V	MS1H1-10C30CB-A3/V33*R-INT	1000	0.82	3000	7000	80×80	3.18	11.13	2.61	SV660*-S7R6I(-FS)-INT	7.6	23	C	1.3	S6-L-M111*(-T)-INT	S6-L-B111*(-T)-INT			S6-L-T00-3.0	S6-C4A S6-C4A-NB
	MS1H4-10C30CB-A3/V33*R-INT	1000	1.87	3000	7000	80×80	3.18	11.13	2.55	SV660*-S7R6I(-FS)-INT	7.6	23	C	1.3						
	MS1H2-10C30CB-A3/V33*R-INT	1000	1.78	3000	6000	100×100	3.18	9.54	3.85	SV660*-S7R6I(-FS)-INT	7.6	23	C	1.3						
	MS1H2-15C30CB-A3/V33*R-INT	1500	2.35	3000	6000	100×100	4.9	14.7	4.65	SV660*-S012I(-FS)-INT	11.6	32	D	1.8						
	MS1H2-20C30CB-A3/V33*R-INT	2000	2.92	3000	6000	100×100	6.36	19.1	5.5	SV660*-S012I(-FS)-INT	11.6	32	D	1.8						
	MS1H3-85B15CB-A3/V33*R-INT	850	13.56	1500	4500	130×130	5.39	13.9	5.8	SV660*-S7R6I(-FS)-INT	7.6	23	C	1.3						
	MS1H3-13C15CB-A3/V33*R-INT	1300	19.25	1500	4500	130×130	8.34	20.85	7.1	SV660*-S012I(-FS)-INT	11.6	32	D	1.8						
3PH 380V	MS1H3-18C15CB-A3/V33*R-INT	1800	24.9	1500	4500	130×130	11.5	28.75	8.5	SV660*-S012I(-FS)-INT	11.6	32	D	1.8	S6-L-M111*(-T)-INT	S6-L-B111*(-T)-INT	S6-L-P111*(-T)-INT	S6-L-P121*(-T)-INT		
	MS1H2-10C30CD-A3/V33*R-INT	1000	1.78	3000	6000	100×100	3.18	9.54	11	SV660*-T3R5I(-FS)-INT	3.5	11	C	1.3						
	MS1H2-15C30CD-A3/V33*R-INT	1500	2.35	3000	6000	100×100	4.9	14.7	14	SV660*-T5R4I(-FS)-INT	5.4	14	C	1.3						
	MS1H2-20C30CD-A3/V33*R-INT	2000	2.92	3000	6000	100×100	6.36	19.1	20	SV660*-T8R4I(-FS)-INT	8.4	20	D	1.8						
	MS1H2-25C30CD-A3/V33*R-INT	2500	3.49	3000	6000	100×100	7.96	23.9	29.75	SV660*-T012I(-FS)-INT	11.9	29.75	D	1.8						
	MS1H2-30C30CD-A3/V33*R-INT	3000	6.4	3000	6000	130×130	9.8	29.4	29.75	SV660*-T012I(-FS)-INT	11.9	29.75	D	1.8						
	MS1H2-40C30CD-A3/V33*R-INT	4000	9	3000	6000	130×130	12.6	37.8	41.25	SV660*-T017I(-FS)-INT	16.5	41.25	E	3.6						
	MS1H2-50C30CD-A3/V33*R-INT	5000	11.6	3000	6000	130×130	15.8	47.4	51.12	SV660*-T021I(-FS)-INT	20.8	51.12	E	3.6						
	MS1H3-85B15CD-A3/V33*R-INT	850	13.56	1500	4500	130×130	5.39	13.5	11	SV660*-T3R5I(-FS)-INT	3.5	11	C	1.3						
	MS1H3-13C15CD-A3/V33*R-INT	1300	19.25	1500	4500	130×130	8.34	20.85	14	SV660*-T5R4I(-FS)-INT	5.4	14	C	1.3						
	MS1H3-18C15CD-A3/V33*R-INT	1800	24.9	1500	4500	130×130	11.5	28.75	20	SV660*-T8R4I(-FS)-INT	8.4	20	D	1.8						
	MS1H3-29C15CD-A3/V33*R-INT	2900	44.7	1500	4500	180×180	18.6	46.5	29.75	SV660*-T012I(-FS)-INT	11.9	29.75	D	1.8						
	MS1H3-44C15CD-A3/V33*R-INT	4400	64.9	1500	4500	180×180	28.4	71.1	41.25	SV660*-T017I(-FS)-INT	16.5	41.25	E	3.6						
MS1H3-55C15CD-A3/V33*R-INT	5500	86.9	1500	4500	180×180	35	87.6	52.12	SV660*-T021I(-FS)-INT	20.8	52.12	E	3.6							
MS1H3-75C15CD-A3/V33*R-INT	7500	127.5	1500	4500	180×180	48	119	64.25	SV660*-T026I(-FS)-INT	25.7	64.25	E	3.6							

Note: [1] For cables, “*” refers to cable length, and the standard cable lengths available are 3.0, 5.0, and 10.0 meters.

[2] MS1 A3 motor is a standard motor; MS1 V3 motor is a battery-less encoder motor.

When the V3 motor is adopted, a battery box is not required.

[3] Brake option not available.

[4] The 40 Frame size motor has no V3 models.

SV660ND Series-Selection

Voltage Class	Servo Motor									Servo Drive					Cable ^[1]					
	MS1 motor model ^[2]	Rated power (W)	Rotor inertia (kg·c·m ²)	Rated speed (rpm)	Max. speed (rpm)	Frame size (mm)	Rated torque (N·m)	Max. torque (N·m)	Motor Weight (kg)	SV660ND drive model	Rated current (A)	Max. current (A)	Size	Drive Weight (kg)	Power Cable		Encoder cable		Communication cable	Battery Box
															Without brake	With brake	Single-turn absolute encoder	Multi-turn absolute encoder	PC communication cable	
1/3PH 220V	MS1H1-40B30CB-A3/V33*R-INT	400	0.145	3000	7000	60×60	1.27	4.45	1.11	SV660ND*-S2R8I(-FS)-INT	2.8	10.1	A	1.4	Front outlet: S6-L-M107*(-T)-INT Rear outlet: S6-L-M108*(-T)-INT	Front outlet: S6-L-B107*(-T)-INT Rear outlet: S6-L-B108*(-T)-INT	Front outlet: S6-L-P114*(-T)-INT Rear outlet: S6-L-P115*(-T)-INT	Front outlet: S6-L-P124*(-T)-INT Rear outlet: S6-L-P125*(-T)-INT	S6-L-T00-3.0	S6-C4A S6-C4A-NB
	MS1H1-55B30CB-A3/V33*R-INT ^[3]	550	0.55	3000	7000	80×80	1.75	6.13	1.88	SV660ND*-S5R5I(-FS)-INT	5.5	16.9	B	1.8						
	MS1H1-75B30CB-A3/V33*R-INT	750	0.68	3000	7000	80×80	2.39	8.37	2.22	SV660ND*-S5R5I(-FS)-INT	5.5	16.9	B	1.8						
	MS1H4-40B30CB-A3/V33*R-INT	400	0.43	3000	7000	60×60	1.27	4.45	1.11	SV660ND*-S2R8I(-FS)-INT	2.8	10.1	A	1.4						
	MS1H4-55B30CB-A3/V33*R-INT ^[3]	550	1.12	3000	7000	80×80	1.75	6.13	1.85	SV660ND*-S5R5I(-FS)-INT	5.5	16.9	B	1.8						
	MS1H4-75B30CB-A3/V33*R-INT	750	1.46	3000	7000	80×80	2.39	8.37	2.18	SV660ND*-S5R5I(-FS)-INT	5.5	16.9	B	1.8						

Note: [1] For cables, "*" refers to cable length, and the standard cable lengths available are 3.0, 5.0, and 10.0 meters.

[2] MS1 A3 motor is a standard motor; MS1 V3 motor is a battery-less encoder motor.
When the V3 motor is adopted, a battery box is not required.

[3] Brake option not available.



SV630 Series-Selection

Voltage Class	Servo Motor									Servo Drive					Cable ^[1]					
	MS1 motor model	Rated power (W)	Rotor inertia (kg·cm ²)	Rated speed (rpm)	Max. speed (rpm)	Frame size (mm)	Rated torque (N·m)	Max. torque (N·m)	Motor Weight (kg)	SV630 drive model	Rated current (A)	Max. current (A)	Size	Drive Weight (kg)	Power Cable		Encoder cable		Encoder cable	Battery Box
															Without brake	With brake	Single-turn absolute encoder	Multi-turn absolute encoder	Encoder cable	
1PH 220V	MS1H1-05B30CB-T330(/2)R-INT	50	0.018	3000	6000	40×40	0.16	0.56	0.26	SV630*S1R6I(-FS)-INT	1.6	5.8	A	0.8	Front outlet: S6-L-M107*(-T)-INT Rear outlet: S6-L-M108*(-T)-INT	Front outlet: S6-L-B107*(-T)-INT Rear outlet: S6-L-B108*(-T)-INT	Front outlet: S6-L-P114*(-T)-INT Rear outlet: S6-L-P115*(-T)-INT	Front outlet: S6-L-P124*(-T)-INT Rear outlet: S6-L-P125*(-T)-INT		
	MS1H1-10B30CB-T330(/2)R-INT	100	0.0316	3000	6000	40×40	0.32	1.12	0.35	SV630*S1R6I(-FS)-INT	1.6	5.8	A	0.8						
	MS1H4-05B30CB-T331(/4)R-INT	50	0.038	3000	6000	40×40	0.16	0.56	0.26	SV630*S1R6I(-FS)-INT	1.6	5.8	A	0.8						
	MS1H4-10B30CB-T331(/4)R-INT	100	0.072	3000	6000	40×40	0.32	1.12	0.32	SV630*S1R6I(-FS)-INT	1.6	5.8	A	0.8						
	MS1H4-20B30CB-T331(/4)R-INT	200	0.22	3000	6000	60×60	0.64	2.24	0.78	SV630*S1R6I(-FS)-INT	1.6	5.8	A	0.8						
	MS1H4-40B30CB-T331(/4)R-INT	400	0.43	3000	6000	60×60	1.27	4.45	1.11	SV630*S2R8I(-FS)-INT	2.8	10.1	A	0.8						
	MS1H4-55B30CB-T331R-INT ^[2]	550	1.12	3000	6000	80×80	1.75	6.13	1.85	SV630*S5R5I(-FS)-INT	5.5	16.9	B	1						
	MS1H4-75B30CB-T331(/4)R-INT	750	1.78	3000	6000	80×80	2.39	8.37	2.18	SV630*S5R5I(-FS)-INT	5.5	16.9	B	1						
1/3PH 220V	MS1H4-10C30CB-T331(/4)R-INT	1000	1.87	3000	6000	80×80	3.18	9.54	2.55	SV630*S7R6I(-FS)-INT	7.6	23	C	1.3	S6-L-M111*(-T)-INT	S6-L-B111*(-T)-INT			S6-L-T00-3.0	S6-C4A S6-C4A-NB
	MS1H2-10C30CB-T331(/4)R-INT	1000	1.78	3000	6000	100×100	3.18	9.54	3.85	SV630*S7R6I(-FS)-INT	7.6	23	C	1.3						
	MS1H3-85B15CB-T331(/4)R-INT	850	13.56	1500	3000	130×130	5.39	13.5	5.8	SV630*S7R6I(-FS)-INT	7.6	23	C	1.3						
	MS1H2-15C30CB-T331(/4)R-INT	1500	2.35	3000	5000	100×100	4.9	14.7	4.65	SV630*S012I(-FS)-INT	12	32	D	1.8						
	MS1H2-20C30CB-T331(/4)R-INT	2000	2.92	3000	5000	100×100	6.36	15.5	5.5	SV630*S012I(-FS)-INT	12	32	D	1.8						
	MS1H3-13C15CB-T331(/4)R-INT	1300	19.25	1500	3000	130×130	8.34	20.85	7.1	SV630*S012I(-FS)-INT	12	32	D	1.8						
	MS1H3-18C15CB-T331(/4)R-INT	1800	24.9	1500	3000	130×130	11.5	28.75	8.5	SV630*S012I(-FS)-INT	12	32	D	1.8						
3PH 380V	MS1H2-10C30CD-T331(/4)R-INT	1000	1.78	3000	6000	100×100	3.18	9.54	3.85	SV630*T3R5I(-FS)-INT	3.5	11	C	1.3	S6-L-M111*(-T)-INT	S6-L-B111*(-T)-INT	S6-L-P111*(-T)-INT	S6-L-P121*(-T)-INT		
	MS1H3-85B15CD-T331(/4)R-INT	850	13.56	1500	3000	130×130	5.39	13.5	5.8	SV630*T3R5I(-FS)-INT	3.5	11	C	1.3						
	MS1H2-15C30CD-T331(/4)R-INT	1500	2.35	3000	5000	100×100	4.9	14.7	4.65	SV630*T5R4I(-FS)-INT	5.4	14	C	1.3						
	MS1H3-13C15CD-T331(/4)R-INT	1300	19.25	1500	3000	130×130	8.34	20.85	7.1	SV630*T5R4I(-FS)-INT	5.4	14	C	1.3						
	MS1H2-20C30CD-T331(/4)R-INT	2000	2.92	3000	5000	100×100	11.5	28.75	5.5	SV630*T8R4I(-FS)-INT	8.4	20	D	1.8						
	MS1H3-18C15CD-T331(/4)R-INT	1800	24.9	1500	3000	130×130	11.5	28.75	8.5	SV630*T8R4I(-FS)-INT	8.4	20	D	1.8						
	MS1H2-25C30CD-T331(/4)R-INT	2500	3.49	3000	5000	100×100	7.96	23.9	6.3	SV630*T012I(-FS)-INT	12	29.75	D	1.8						
	MS1H2-30C30CD-T331(/4)R-INT	3000	6.4	3000	5000	130×130	9.8	29.4	10	SV630*T012I(-FS)-INT	12	29.75	D	1.8						
	MS1H3-29C15CD-T331(/4)R-INT	2900	44.7	1500	3000	180×180	18.6	46.5	13.8	SV630*T012I(-FS)-INT	12	29.75	D	1.8						
	MS1H2-40C30CD-T331(/4)R-INT	4000	9	3000	5000	130×130	12.6	37.8	13.2	SV630*T017I(-FS)-INT	17	41.25	E	3.6						
	MS1H3-44C15CD-T331(/4)R-INT	4400	64.9	1500	3000	180×180	28.4	71.1	17.4	SV630*T017I(-FS)-INT	17	41.25	E	3.6						
	MS1H2-50C30CD-T331(/4)R-INT	5000	11.6	3000	5000	130×130	15.8	47.4	16.35	SV630*T021I(-FS)-INT	21	52.12	E	3.6						
	MS1H3-55C15CD-T331(/4)R-INT	5500	86.9	1500	3000	180×180	35	87.6	21.7	SV630*T021I(-FS)-INT	21	52.12	E	3.6						
MS1H3-75C15CD-T331(/4)R-INT	7500	127.5	1500	3000	180×180	48	119	29	SV630*T026I(-FS)-INT	26	64.25	E	3.6							

Note: [1] For cables, "*" refers to cable length, and the standard cable lengths available are 3.0, 5.0, and 10.0 meters
 [2] Brake option not available