



## MS1 Series Low-Voltage Servo Motor User Guide



Industrial  
Automation



Intelligent  
Elevator



New Energy  
Vehicle



Industrial  
Robot



Rail  
Transit



Data code PS00011274A03

## Legal Information

### Copyright

Copyright © Shenzhen Inovance Technology Co., Ltd. 2024 All rights reserved

This documentation is the exclusive property of Shenzhen Inovance Technology Co., Ltd. No individual or entity may excerpt, reproduce, modify, translate, or distribute any content herein without written consent from Inovance.

Legal action will be taken against infringement.

### Trademarks

**INOVANCE** is a registered trademark of Shenzhen Inovance Technology Co., Ltd. and its affiliates. All other trademarks or registered trademarks mentioned in this documentation are the property of their respective owners. Unauthorized use of these trademarks by third parties for any purpose without written authorization could violate the rights of their owners.

### Disclaimer of Liability

Due to continuous updates and improvements of products and technologies, the content of this documentation may not fully match the actual products. In the event of any discrepancies, the actual products shall prevail.

The contents are subject to change without notice due to product upgrade.

### Waste Disposal

The storage, use, and disposal of this product (including optional accessories) must comply with local laws and regulations.

### Qualified Personnel

The product/system described in this documentation may be operated only by personnel qualified for the specific task in accordance with the relevant documentation, in particular its warning notices and safety instructions. Qualified personnel can identify the risks of the product/system and prevent possible dangers.

### Proper Use of the Product

Proper transportation, storage, assembly, installation, commissioning, operation, and maintenance are required to ensure the safe operation of the product without any problems. The required ambient conditions must be met. All operations must follow the guidelines provided in this documentation.

# Preface

## Introduction

Thank you for purchasing the MS1 series low-voltage servo motor.

The MS1 series low-voltage servo motor is equipped with a 23-bit multi-turn absolute encoder. It features small size, high performance, and high reliability to fit the application needs of automatic guided vehicles, pharmaceutical industry, and logistics automation. The motor covers a power range of 0.1 kW to 0.75 kW and frame sizes 40, 60, and 80. The motor brake is optional.

This series of motors can be widely applied in applications requiring low voltage and small footprint, such as logistics warehouse equipment, handling devices, sorting AGVs, and mobile service robots.

This user guide presents information including product information, motor selection, and motor wiring. Contact Inovance for detailed information on the motor function and performance.

Documents provided by Inovance are subject to change without notice due to continuous product improvement.

---

### **Note**

- The drawings in the user guide are sometimes shown without covers or protective guards. Remember to install the covers or protective guards as specified first, and then perform operations in accordance with the instructions.
  - The drawings in the user guide are shown for description only and may not match the product you purchased.
  - The user guide is subject to change without notice due to product upgrade, specification modifications as well as efforts to improve the accuracy and convenience of the user guide.
-

## Revision History

Date	Version	Revision
October 2025	A03	<ul style="list-style-type: none"> <li>• Updated “3.4 Motor Model” on page 15.</li> <li>• Updated “4.1 Mechanical Specifications” on page 16.</li> <li>• Updated “5.1 MS1H4-10B30CA-A331R(-S) and MS1H4-10B30CA-A334R(-S)” on page 24.</li> <li>• Updated “5.2 MS1H4-20B30CA-A331R and MS1H4-20B30CA-A334R” on page 27.</li> <li>• Updated “5.3 MS1H4-40B30CA-A331R-S and MS1H4-40B30CA-A334R-S” on page 29.</li> <li>• Updated “5.4 MS1H4-75B30CA-A331R-S and MS1H4-75B30CA-A334R-S” on page 31.</li> <li>• Updated “6.3 Applicable Cable List” on page 35.</li> <li>• Updated “6.4.2 Encoder Cable Terminals” on page 40.</li> </ul>
September 2024	A02	<p><b>Added the following section:</b></p> <ul style="list-style-type: none"> <li>• Added “5.1 MS1H4-10B30CA-A331R(-S) and MS1H4-10B30CA-A334R(-S)” on page 24.</li> <li>• “5.2 MS1H4-20B30CA-A331R and MS1H4-20B30CA-A334R” on page 27.</li> </ul> <p><b>Updated the following sections:</b></p> <ul style="list-style-type: none"> <li>• Updated “Applicable Model List” on page 12.</li> <li>• Updated “3.2 Model and Nameplate” on page 13.</li> <li>• Updated “3.3 Components” on page 14.</li> <li>• Updated “3.4 Motor Model” on page 15.</li> <li>• Updated “4.2 Overload Characteristics” on page 18.</li> <li>• Updated “Model Selection” on page 23.</li> <li>• Updated “5.3 MS1H4-40B30CA-A331R-S and MS1H4-40B30CA-A334R-S” on page 29.</li> <li>• Updated “5.4 MS1H4-75B30CA-A331R-S and MS1H4-75B30CA-A334R-S” on page 31.</li> <li>• Updated “6.3 Applicable Cable List” on page 35.</li> <li>• Updated “6.4.1 Power Cable Terminals” on page 37.</li> <li>• Updated “6.4.2 Encoder Cable Terminals” on page 40.</li> </ul>
August 2023	A01	Updated the "Torque-Speed characteristics" figures in Chapter 4.
June 2023	A00	Initial release

## Access to the Guide

This guide is not delivered with the product. You can download the PDF version in the following ways:

- Do keyword search under Service and Support at [www.inovance.com](http://www.inovance.com).
- Scan the QR code on the product with your smart phone.
- Scan the QR code below to install My Inovance app, where you can search for and download user guides.



## Warranty disclaimer

Inovance provides warranty service within the warranty period (as specified in your order) for any fault or damage that is not caused by improper operation of the user. Maintenance can be charged after the warranty period expires.

Within the warranty period, maintenance can be charged for the following damage:

- Damage caused by operations not following the instructions in the user guide
- Damage caused by fire, flood, or unusual voltage
- Damage caused by unintended use of the product
- Damage caused by use beyond the specified scope of application of the product
- Damage or secondary damage caused by force majeure (natural disaster, earthquake, and lightning strike)

The maintenance is charged according to the latest Price List of Inovance. If otherwise agreed upon, the terms and conditions in the agreement shall prevail.

For details, see Product Warranty Card.

# Table of Contents

Legal Information.....	1
Preface .....	1
1 Fundamental Safety Instructions.....	6
1.1 Fundamental Safety Instructions .....	6
1.2 Industrial Information Security.....	11
2 Model List.....	12
3 Product Information.....	13
3.1 Product Features.....	13
3.2 Model and Nameplate .....	13
3.3 Components.....	14
3.4 Motor Model.....	15
4 Product Specifications .....	16
4.1 Mechanical Specifications .....	16
4.2 Overload Characteristics.....	18
4.3 Derating Characteristics .....	21
4.4 Temperature Curve of the Oil Seal.....	21
4.5 Load Moment of Inertia .....	21
5 Model Selection .....	23
5.1 MS1H4-10B30CA-A331R(-S) and MS1H4-10B30CA-A334R(-S) .....	24
5.2 MS1H4-20B30CA-A331R and MS1H4-20B30CA-A334R .....	27
5.3 MS1H4-40B30CA-A331R-S and MS1H4-40B30CA-A334R-S .....	29
5.4 MS1H4-75B30CA-A331R-S and MS1H4-75B30CA-A334R-S .....	31
6 Cable Selection.....	33
6.1 Model Description .....	33
6.2 Cable Type.....	34
6.3 Applicable Cable List.....	35
6.4 Cable Terminals.....	37
6.4.1 Power Cable Terminals .....	37
6.4.2 Encoder Cable Terminals .....	40
7 Installation Preparation .....	43

7.1 Installation Environment.....	43
7.2 Installation Personnel.....	43
7.3 Installation Tools .....	44
7.4 Installation Precautions.....	45
8 Unpacking and Handling .....	46
8.1 Unpacking .....	46
8.2 Handling.....	47
8.3 Storage .....	47
9 Wiring .....	49
10 Maintenance Interval.....	50
11 Maintenance .....	51
11.1 Routine Maintenance .....	51
11.1.1 Routine Checklist.....	51
11.1.2 Routine Cleaning.....	51
11.2 Regular Checklist.....	51
12 Certifications and Standards .....	53
13 Service and Support .....	54
13.1 Service and Support .....	54

# 1 Fundamental Safety Instructions

## 1.1 Fundamental Safety Instructions

### Safety Precautions

- This chapter provides essential safety instructions for proper use of the equipment. Before operating the equipment, read through the guide and comprehend all the safety instructions. Failure to observe the safety instructions may result in death, personal injury, or equipment damage.
- "DANGER", "WARNING", and "CAUTION" in this guide only indicate some of the precautions that need to be followed; they just supplement the safety precautions.
- Use this product according to designated environment requirements. Damage caused by improper use is not covered by warranty.
- Inovance shall take no responsibility for any personal injury or property damage caused by improper use.

### Safety Levels and Definitions



Indicates that failure to comply with the notice can result in death or severe personal injury.







Indicates that failure to comply with the notice may result in severe personal injury or even death.





Indicates that failure to comply with the notice may result in minor or moderate personal injury or equipment damage.

### General Safety Instructions

- Drawings in the guide are sometimes shown without covers or protective guards. Remember to install the covers or protective guards as specified first, and then perform operations in accordance with the instructions.
- The drawings in the guide are shown for illustration only and may be different from the product you purchased.
- Operators must take mechanical precautions to protect personal safety and wear protective equipment, such as anti-smashing shoes, safety clothing, safety glasses, protective gloves, and protective sleeves.

<b>Unpacking</b>	
 <b>WARNING</b>	<ul style="list-style-type: none"><li>• Do not install the equipment if you find damage, rust, or signs of use on the equipment or accessories upon unpacking.</li><li>• Do not install the equipment if you find water seepage or missing or damaged components upon unpacking.</li><li>• Do not install the equipment if you find the packing list does not conform to the equipment you received.</li></ul>
 <b>CAUTION</b>	<ul style="list-style-type: none"><li>• Check whether the packing is intact and whether there is damage, water seepage, dampness, and deformation before unpacking.</li><li>• Unpack the package in sequence. Do not hit the package violently.</li><li>• Check whether there is damage, rust, or signs of bumping on the surface of the equipment and equipment accessories before unpacking.</li><li>• Check whether the package contents are consistent with the packing list before unpacking.</li></ul>
<b>Storage and transportation</b>	
 <b>WARNING</b>	<ul style="list-style-type: none"><li>• Large-scale or heavy equipment must be handled by qualified professionals using specialized hoisting equipment. Failure to comply may result in personal injury or equipment damage.</li><li>• Before hoisting the equipment, ensure that components such as the front cover and terminal blocks are secured firmly with screws. Loosely-connected components may fall off and result in personal injury or equipment damage.</li><li>• Never stand or stay below the equipment when the equipment is being hoisted by the hoisting equipment.</li><li>• When hoisting the equipment with a steel rope, ensure the equipment is hoisted at a constant speed without suffering from vibration or shock. Do not turn the equipment over or let the equipment stay hanging in the air. Failure to comply may result in personal injury or equipment damage.</li></ul>
 <b>CAUTION</b>	<ul style="list-style-type: none"><li>• Handle the equipment with care during transportation and mind your steps to prevent personal injury or equipment damage.</li><li>• When carrying the equipment with bare hands, hold the equipment casing firmly with care to prevent parts from falling. Failure to comply may result in personal injury.</li><li>• Store and transport the equipment based on the storage and transportation requirements. Failure to comply may result in equipment damage.</li><li>• Avoid storing or transporting the equipment in environments with water splash, rain, direct sunlight, strong electric field, strong magnetic field, and strong vibration.</li><li>• Avoid storing the product for more than 3 months. When the product needs to be stored for an extended period, take more strict protection and necessary inspection.</li><li>• Pack the equipment strictly before transportation. Use a sealed box for long-distance transportation.</li><li>• Never transport the equipment with other equipment or materials that may harm or have negative impacts on the product.</li></ul>

<b>Installation</b>	
 <b>DANGER</b>	<ul style="list-style-type: none"> <li>• Installation must be carried out by skilled personnel who have undergone specialized electrical training and possess comprehensive electrical expertise. Non-professionals are not allowed to install the equipment.</li> </ul>
 <b>WARNING</b>	<ul style="list-style-type: none"> <li>• Read through the guide and safety precautions before installation.</li> <li>• Do not install the equipment in places with strong electric or magnetic fields.</li> <li>• Before installation, check that the mechanical strength of the installation site can bear the weight of the equipment. Failure to comply will result in mechanical hazards.</li> <li>• Do not wear loose clothes or accessories during installation. Failure to comply may result in electric shock.</li> <li>• When installing the equipment in a closed environment (such as a cabinet or casing), use a cooling device (such as a fan or air conditioner) to cool the environment down to the required temperature. Failure to comply may result in equipment over-temperature or a fire.</li> <li>• Do not retrofit the equipment.</li> <li>• Do not fiddle with the bolts used to fix equipment components or the bolts marked in red.</li> <li>• When the equipment is installed in a cabinet or final assembly, a fireproof enclosure providing both electrical and mechanical protections must be provided. The IP rating must meet IEC standards and local laws and regulations.</li> <li>• Before installing equipments with strong electromagnetic interference, such as a transformer, install a shielding equipment for the equipment to prevent malfunction.</li> <li>• Install the product on an incombustible object such as metal and do not contact or attach the product with combustible objects. Failure to comply will cause fires.</li> </ul>
 <b>CAUTION</b>	<ul style="list-style-type: none"> <li>• Cover the top of the equipment with a piece of cloth or paper during installation. This is to prevent unwanted objects such as metal chippings, oil, and water from falling into the equipment and causing faults. After installation, remove the cloth or paper to prevent over-temperature caused by poor ventilation due to blocked ventilation holes.</li> <li>• Resonance may occur when the equipment operating at a constant speed switches to variable speed operations. In this case, install the vibration-proof rubber under the motor frame or use the vibration suppression function to reduce resonance.</li> </ul>

**Wiring**



- Equipment installation, wiring, maintenance, inspection, or component replacement must be performed only by professionals.
- Before wiring, disconnect all the power supplies of the equipment. Wait for at least the time designated on the equipment warning label before further operations because residual voltage still exists after power-off. Measure the DC voltage of the main circuit and make sure that it is below the safety voltage. Failure to comply can result in electric shock.
- Do not perform wiring, remove the equipment cover, or touch the circuit board with power ON. Failure to comply will result in an electric shock.
- Check that the equipment is grounded properly. Failure to comply will result in an electric shock.



- Do not connect the input power supply to the output end of the equipment. Failure to comply will result in equipment damage or even a fire.
- When connecting a drive to the motor, check that the phase sequences of the drive and motor terminals are consistent to prevent reverse motor rotation.
- Cables used for wiring must meet cross sectional area and shielding requirements. The shield of the cable must be reliably grounded at one end.
- Tighten the terminal screws with the tightening torque specified in the user guide. Improper tightening torque may result in overheat, damage to the connecting parts, or a fire.
- After wiring is done, check that all cables are connected properly and no screws, washers or exposed cables are left inside the equipment. Failure to comply may result in electric shock or equipment damage.



- During wiring, follow the proper electrostatic discharge (ESD) procedures, and wear an antistatic wrist strap. Failure to comply will result in damage to internal equipment circuits.
- Use shielded twisted pairs for the control circuit. Connect the shield to the grounding terminal of the equipment for grounding purpose. Failure to comply can result in equipment malfunction.







**Power-on**



- Before power-on, check that the equipment is installed properly with reliable wiring and the motor can be restarted.
- Check that the power supply meets equipment requirements before power-on to prevent equipment damage or a fire.
- When the equipment is powered on, do not open the cabinet door or protective cover, touch any wiring terminal, or disassemble any component of the equipment. Failure to comply can result in electric shock.





- Perform a trial run after wiring and parameter setting to ensure that the equipment operates safely. Failure to comply may result in personal injury or equipment damage.
- Before power-on, check that the rated voltage of the equipment is consistent with that of the power supply. Failure to comply may result in a fire. Failure to comply may result in fire accident.
- Before power-on, check that no one is near the equipment, motor, or machine. Failure to comply may result in death or personal injury.

<b>Operation</b>
<div style="border: 1px solid black; padding: 2px; display: inline-block;"> DANGER</div> <ul style="list-style-type: none"> <li>• The equipment must be operated only by professionals. Failure to comply can result in death or personal injury.</li> <li>• During operation, do not touch any connecting terminals or disassemble any component of the equipment. Failure to comply can result in electric shock.</li> </ul>
<div style="border: 1px solid black; padding: 2px; display: inline-block;"> WARNING</div> <ul style="list-style-type: none"> <li>• Do not touch the equipment enclosure, fan, or resistor with bare hands. Failure to comply may result in burns.</li> <li>• During operation, prevent metal or other objects from falling into the equipment. Failure to comply may result in fire or equipment damage.</li> </ul>
<b>Maintenance</b>
<div style="border: 1px solid black; padding: 2px; display: inline-block;"> DANGER</div> <ul style="list-style-type: none"> <li>• Equipment installation, wiring, maintenance, inspection, or component replacement must be performed only by professionals.</li> <li>• Do not maintain the equipment with power ON. Failure to comply can result in electric shock.</li> <li>• Before maintenance, disconnect all the power supplies of the equipment and wait for at least the time designated on the equipment warning label.</li> <li>• When a permanent magnet motor is used, do not touch the motor terminals immediately after power-off because the motor terminals can generate induced voltage during rotation even after the equipment is powered off. Failure to comply can result in electric shock.</li> </ul>
<div style="border: 1px solid black; padding: 2px; display: inline-block;"> WARNING</div> <ul style="list-style-type: none"> <li>• Perform routine and regular inspection and maintenance on the equipment in accordance with maintenance requirements and keep a record.</li> </ul>
<b>Repair</b>
<div style="border: 1px solid black; padding: 2px; display: inline-block;"> DANGER</div> <ul style="list-style-type: none"> <li>• Equipment installation, wiring, maintenance, inspection, or component replacement must be performed only by professionals.</li> <li>• Do not perform maintenance on the equipment with power on. Failure to comply can result in electric shock.</li> <li>• Before inspection and maintenance, disconnect all the power supplies of the equipment and wait for at least the time designated on the equipment warning label.</li> </ul>
<div style="border: 1px solid black; padding: 2px; display: inline-block;"> WARNING</div> <ul style="list-style-type: none"> <li>• Submit a request for repair services in accordance with the product warranty agreement.</li> <li>• When the fuse is blown or the circuit breaker or earth leakage current breaker (ELCB) trips, wait for at least the time designated on the equipment warning label before power-on or further operations. Failure to comply may result in death, personal injury, or equipment damage.</li> <li>• Troubleshooting and repair must be performed by professionals in accordance with the repair instructions, with repair records kept properly.</li> <li>• Replace quick-wear parts of the equipment in accordance with the replacement instructions.</li> <li>• Do not use damaged equipment. Failure to comply may result in death, personal injury, or severe equipment damage.</li> <li>• After the equipment is replaced, check the wiring and set parameters again.</li> </ul>

Disposal	
 <b>WARNING</b>	<ul style="list-style-type: none"> <li>• Dispose of retired equipment in accordance with local regulations and standards. Failure to comply may result in death, personal injury, or property damage.</li> <li>• Recycle retired equipment in accordance with industry waste disposal standards to avoid environmental pollution.</li> </ul>

## Safety Labels

For safe operation and maintenance, comply with the safety labels on the equipment. Do not damage or remove the safety labels. The following table describes the meaning of the safety labels.

Safety label	Description
	Indicates high temperature may exist.
	Indicates that the motor cannot be subject to violent strike.

## 1.2 Industrial Information Security

The product provides interfaces to connect to the network and transmit data through the network interfaces. In order to protect factories, systems, machines and networks from network attacks and ensure their safe operation, implement appropriate industrial information security protection mechanisms.

The customer is responsible for providing and continuously ensuring a secure connection between the product and the network to prevent unauthorized access to its factories, systems, machines and networks. The system can only be connected to the corporate network or the Internet if it is connected securely and appropriate security measures are in place (for example, using anti-virus software and a firewall).

Inovance continuously develops and improves products and solutions to improve safety. It is strongly recommended that you update the product promptly and always use the latest version.

---

### **Caution**

Tampering with software (such as viruses, Trojans, and Worms) can lead to unsafe drive state, which can put the device in an unsafe operation state. This may result in death, serious injury, and property damage. Observe the following strictly.

- Always use the latest software version. If the product version is no longer supported or the latest version of the program is not applied, customers are at increased risk of cyber-attacks.
  - Take proper protection measures (including but not limited to deploying anti-virus software, firewall, WAF, IPS/IDS, situational awareness system, ID verification, and data encryption) to prevent files in the mobile storage device from being damaged by malware and protect products, networks, systems, and interfaces from unauthorized access, disturbance, intrusion, data disclosure, or information theft.
  - Check all safety-related interfaces and settings after commissioning.
-

## 2 Model List

Servo motor						Servo drive			
Brake-less motor model	No.	Brake motor model	No.	Frame size	Capacity (kW)	Voltage class (V)	Size	Recommended drive model	No.
MS1H4-10B30CA-A331R	01119750	MS1H4-10B30CA-A334R	01119753	40	0.1	24 to 70	A	SVD60C6R5I	01054328
								SVD60N6R5I	01054331
								SVD60C6R5I-FS	01054433
								SVD60N6R5I-FS	01054329
MS1H4-10B30CA-A331R-S	01119754	MS1H4-10B30CA-A334R-S	01119752	40	0.1	24 to 70	A	SVD60C6R5I	01054328
								SVD60N6R5I	01054331
								SVD60C6R5I-FS	01054433
								SVD60N6R5I-FS	01054329
MS1H4-20B30CA-A331R	01119339	MS1H4-20B30CA-A334R	01119560	60	0.2	24 to 70	A	SVD60C6R5I	01054328
								SVD60N6R5I	01054331
								SVD60C6R5I-FS	01054433
								SVD60N6R5I-FS	01054329
MS1H4-40B30CA-A331R-S	01117022	MS1H4-40B30CA-A334R-S	01117023	60	0.4	24 to 70	B	SVD60N012I	01053881
								SVD60N012I-FS	01053894
								SVD60C012I	01053882
								SVD60C012I-FS	01053896
MS1H4-75B30CA-A331R-S	01117020	MS1H4-75B30CA-A334R-S	01117021	80	0.75	24 to 70	B	SVD60N023I	01053879
								SVD60N023I-FS	01053895
								SVD60C023I	01053880
								SVD60C023I-FS	01053897

Table 2-1 Relationship between servo drive and motor encoder

Drive model	Encoder type	Reference
SVD60C6R5I	A3: 23-bit multi-turn absolute encoder	SVD60 Series Servo Drive Selection Guide
SVD60N6R5I	A3: 23-bit multi-turn absolute encoder	
SVD60C6R5I-FS	A3: 23-bit multi-turn absolute encoder	
SVD60N6R5I-FS	A3: 23-bit multi-turn absolute encoder	
SVD60N012I	A3: 23-bit multi-turn absolute encoder	
SVD60N012I-FS	A3: 23-bit multi-turn absolute encoder	
SVD60C012I	A3: 23-bit multi-turn absolute encoder	
SVD60C012I-FS	A3: 23-bit multi-turn absolute encoder	
SVD60N023I	A3: 23-bit multi-turn absolute encoder	
SVD60N023I-FS	A3: 23-bit multi-turn absolute encoder	
SVD60C023I	A3: 23-bit multi-turn absolute encoder	
SVD60C023I-FS	A3: 23-bit multi-turn absolute encoder	

### 3 Product Information

#### 3.1 Product Features

- Small size to save installation space
- High reliability with IP rating up to IP67
- Small speed fluctuation to allow smooth operation
- Strong overload capacity to allow high operating efficiency
- Low temperature rise, low noise, and high applicability

#### 3.2 Model and Nameplate

##### Model description

$\frac{\text{MS1}}{\text{①}} \frac{\text{H4}}{\text{②}} - \frac{\text{40B}}{\text{③}} \frac{\text{30C}}{\text{④}} \frac{\text{A}}{\text{⑤}} - \frac{\text{A3}}{\text{⑥}} \frac{\text{3}}{\text{⑦}} \frac{\text{1}}{\text{⑧}} \frac{\text{R}}{\text{⑨}} - \frac{*}{\text{⑩}}$

① <b>MS1 series servo motor</b>  	④ <b>Rated speed (rpm)</b> One letter and two digits C: x 100 Example: 30C: 3000 rpm	⑦ <b>Shaft connection mode</b> 3: Solid shaft, with key and threaded hole
② <b>Inertia and capacity</b> H4: Medium inertia and small capacity	⑤ <b>Voltage class (V)</b> A: 48	⑧ <b>Brake, reducer, oil seal</b> 1: With oil seal but no brake 4: With oil seal and brake
③ <b>Rated power (W)</b> One letter and two digits B: x 10 Example: 40B: 400 W	⑥ <b>Encoder type</b> One letter and one digit A3: 23-bit multi-turn absolute encoder	⑨ <b>Sub-series No.</b> R: R series
		⑩ <b>Cable outgoing mode</b> _: Terminal type S: Flying leads type

##### Nameplate description

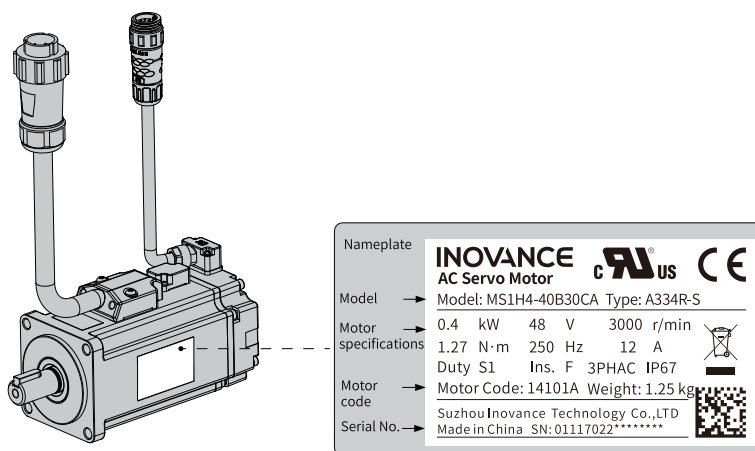

Figure 3-1 Model and Nameplate

### 3.3 Components

#### Terminal-type motor (100 W and 200 W)

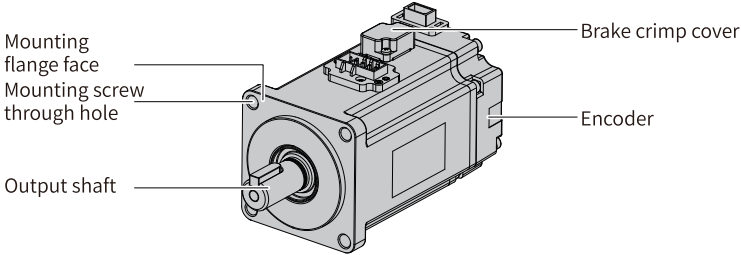

Figure 3-2 MS1H4-20B30CA-A334R

#### Flying leads motor (100 W & 400 W & 750 W)

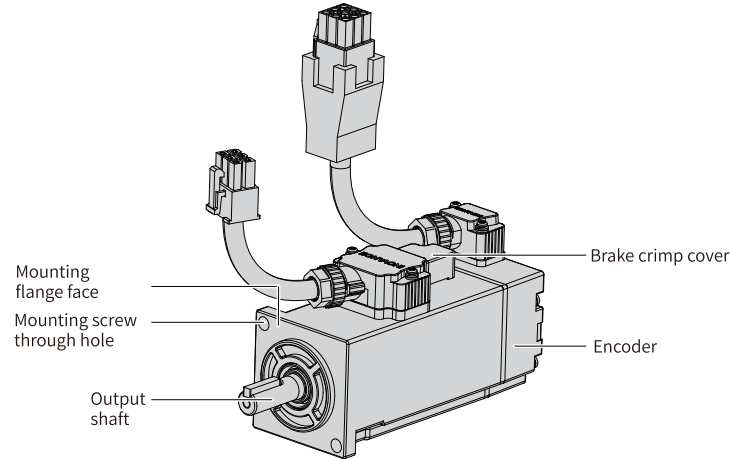

Figure 3-3 MS1H4-10B30CA-A334R-S

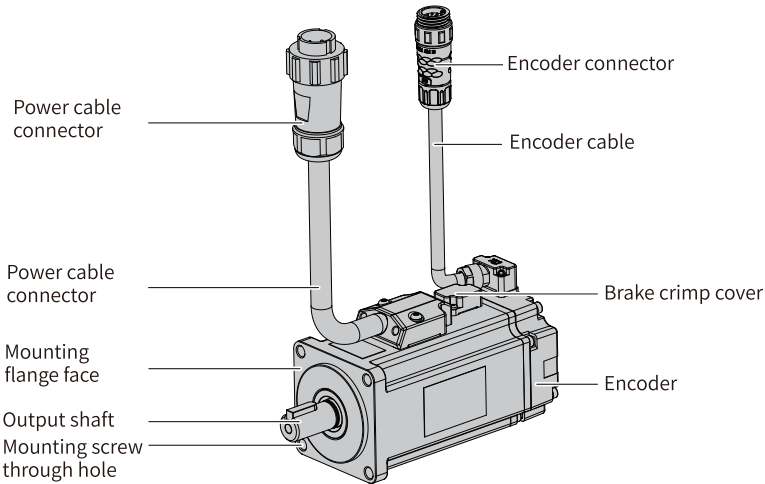

Figure 3-4 MS1H4-40B30CA-A334R-S

### 3.4 Motor Model

Motor type		Rated output capacity (kW)	Rated speed (maximum speed) (rpm)	Encoder	IP rating
Medium inertia Small capacity	Terminal type 	0.1, 0.2	3000 (6000, 0.1 kW) (6000, 0.2 kW)	A3: 23-bit multi-turn absolute encoder	IP67
	Flying leads type 	0.1	3000 (6000, 0.1 kW)	A3: 23-bit multi-turn absolute encoder	IP67
	Flying leads type 	0.4, 0.75	3000 (6000, 0.4 kW) (5000, 0.75 kW)	A3: 23-bit multi-turn absolute encoder	IP67

## 4 Product Specifications

### 4.1 Mechanical Specifications

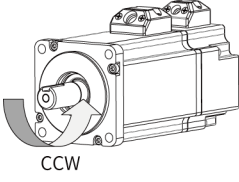
Item		Description
Duty		S1 (Continuous duty)
Vibration class <sup>[1]</sup>		V15
Insulation resistance		500 VDC, above 2 MΩ
Excitation mode		Permanent magnetic
Mounting method		Flange
Thermal class		F
Withstand voltage		596 VAC for 1 minute
IP rating		IP67 (except the shaft opening)
Direction of rotation		Rotates counterclockwise (CCW) when viewed from the shaft extension side with the forward run command. <div style="text-align: center;">  <p>CCW</p> </div>
Ambient condition	Ambient temperature	0°C to 40°C (non-frozen) (Derate the motor based on the derating curve for temperatures above 40°C.)
	Ambient humidity	20% to 80% RH (without condensation)
	Installation location	<ul style="list-style-type: none"> <li>• Free from corrosive or explosive gases</li> <li>• Well ventilated and with minimum amount of dust, waste and moisture</li> <li>• Convenient for inspection and cleanup</li> <li>• Derating is required only for installation altitudes higher than 1000 m. <a href="#">“4.3 Derating Characteristics” on page 21</a></li> <li>• Away from sources that may generate strong a magnetic field</li> <li>• Away from heating sources such as a heating stove</li> <li>• Use the motor with oil seal in places with grinding fluid, oil mist, iron powders or cuttings.</li> <li>• The oil seal is only dust-proof. It cannot withstand the intrusion of oil for a long term.</li> <li>• Not applicable to vacuum environment</li> <li>• Not applicable to inching condition, which may result in locking.</li> <li>• The brake motor may generate a pattering sound, which is normal.</li> <li>• Coupler type and installation alignment requirements</li> <li>• In upstream applications of the motor, ensure the force applied on the shaft end is lower than the allowable axial force and radial force of the motor. Install the coupler based on the permissible mechanical accuracy.</li> <li>• Do not keep the system operating continuously at natural frequency. Exceeding the allowable vibration value may damage the system.</li> </ul>
	Storage environment	Observe the following requirements for storage of a de-energized motor: <ul style="list-style-type: none"> <li>• Storage temperature -20°C to +60°C (non-freezing)</li> <li>• Storage humidity 20% to 80% RH (without condensation)</li> </ul>

Item		Description
Shock resistance [3][4]	Shock acceleration (flange face as standard)	490 m/s <sup>2</sup>
	Number of shocks	2
Vibration resistance [2][4]	Vibration acceleration (flange face as standard)	Radial 49 m/s <sup>2</sup>
		Axial 24.5 m/s <sup>2</sup>

**Note**

- [1] Vibration level V15 indicates that the amplitude of vibration is less than 15 μm when a single servo motor rotates at its rated value.
- [2] For a motor shaft mounted horizontally, the impact resistance level in the up and down directions is shown in the preceding table.
- [3] For a servo motor shaft mounted horizontally, the vibration resistance level in the up/down, left/right, and front/rear directions is shown in the preceding table.
- [4] The vibration intensity applied on the motor is affected by the transmission structure, alignment accuracy, mounting conditions, and external vibration. These factors may enhance the vibration applied on the motor. When the maximum allowable vibration limit is exceeded, the motor may fail. Therefore, take necessary measures to limit resonance.
- The vibration intensity applied on the motor varies with applications.

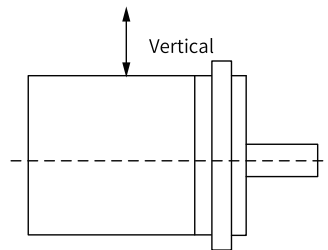

Figure 4-1 Shock applied on the motor

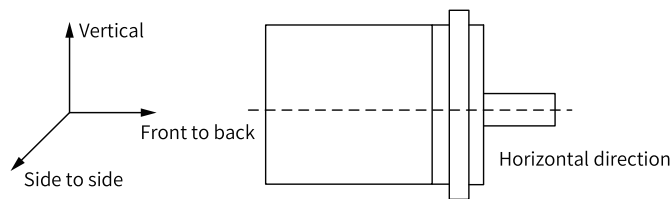

Figure 4-2 Vibration applied on the motor

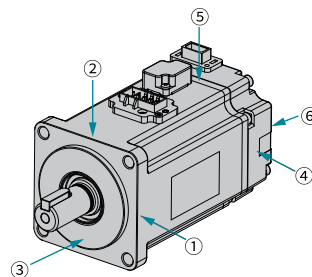

Figure 4-3 Max. allowable vibration limit of the motor

Direction	Measuring point	Limit value (10 Hz to 2000 Hz)
Radial	①②	49 m/s <sup>2</sup>
	④⑤	49 m/s <sup>2</sup>
Axial	③	24.5 m/s <sup>2</sup>
	⑥	24.5 m/s <sup>2</sup>

### Note

The preceding vibration/shock standards cannot be applied for a long term. For long-term application, contact Inovance.

## 4.2 Overload Characteristics

The equipment is compliant with NEC and CEC requirements and equipped with protective functions against overload and overtemperature.

To protect different load motors, set the motor overload protection gain based on the overload capacity of the motor. Use the default gains in general conditions, however, when one of the following condition occurs, change the gains based on the temperature rise condition of the motor:

- The motor works in environments with high ambient temperature.
- The motor is in cyclic motion featuring a short motion cycle and frequent acceleration/ deceleration.
- Overload thermal protection only occurs during continuous energized operation. You need to check the motor temperature when the drive is powered off.

Motor overload protection curve is as follows:

- **MS1H4-10B30CA-A33\*R (-S)**

Load ratio (%)	Operating time (s)
120	6000
125	1360
130	243.9
135 m	98.4
140	44.9
145	29.1
150	20.7
155	16.1
160	13.0
165	11.0
170	9.7
175	8.6
180	7.8
185	7.1
190	6.5
195	6.0
200	5.5
205	5.2
210	4.8
215	4.5
220	4.3
225	4.0

Load ratio (%)	Operating time (s)
230	3.7
235	3.4
240	3.2
245	3.1
250	3.0
255	2.9
260	2.9
265	2.9
270	2.8
275	2.8
280	2.7
285	2.6
290	2.5
295	2.4
300	2.3
305	2.2
310	2.0
315	1.9
320	1.8
325	1.7
330	1.6
335	1.6
340	1.5
345	1.5
350	1.4

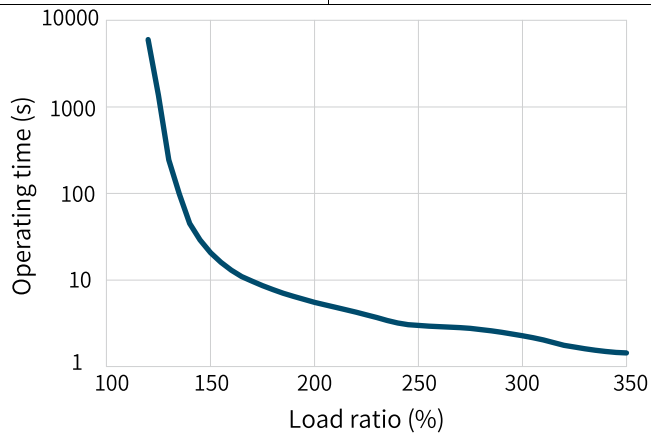

Figure 4-4 MS1H4-10B30CA-A33\*R(-S) motor overload curve

- **MS1H4-20B30CA-A33\*R/MS1H4-40B30CA-A33\*R-S**

Load ratio (%)	Operating time (s)
120	230
130	80
140	40
150	30
160	20
170	17
180	15
190	12
200	10
210	8.5

Load ratio (%)	Operating time (s)
220	7
230	6
240	5.5
250	5
300	3
350	2

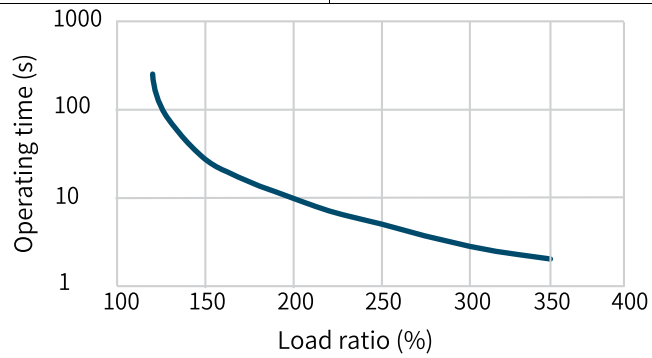

Figure 4-5 MS1H4-20B30CA-A33\*R/MS1H4-40B30CA-A33\*R-S motor overload curve

● **MS1H4-75B30CA-A33\*R-S**

Load ratio (%)	Operating time (s)
120	138
130	48
140	24
150	18
160	12
170	10.2
180	9
190	7.2
200	6
210	5.1
220	4.2
230	3.6
240	3.3
250	3

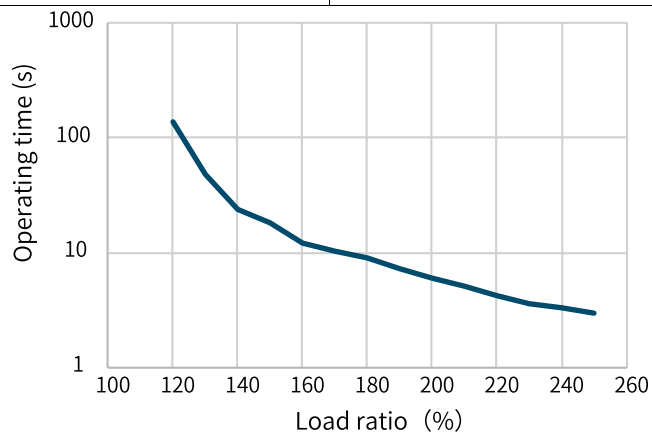
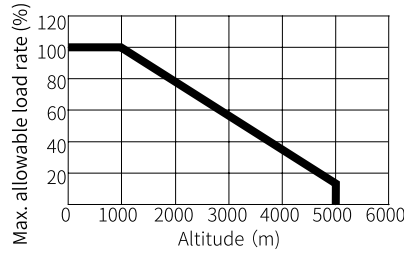

Figure 4-6 MS1H4-75B30CA-A33\*R-S motor overload curve

### 4.3 Derating Characteristics

Altitude-based derating curve



Temperature-based derating curve

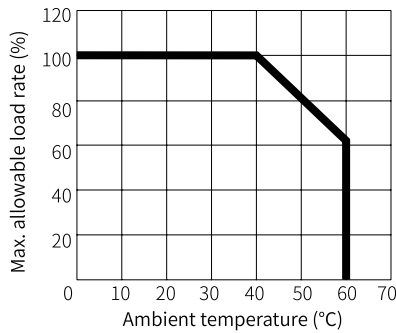

### 4.4 Temperature Curve of the Oil Seal

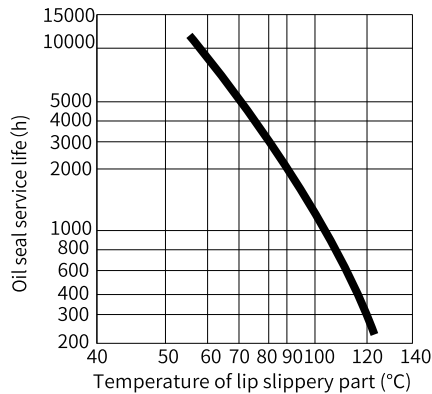

### 4.5 Load Moment of Inertia

The load moment of inertia represents the inertia of the load. The larger the load moment of inertia, the weaker the response can be. An excessively high inertia may result in unstable motion. The permissible load moment of inertia ratio of the servo motor is limited. The value is a general standard and varies according to the driving conditions of the servo motor.

An overvoltage alarm may occur during deceleration if the load moment of inertia exceeds the allowable value. For servo drives with a built-in braking resistor, an overload alarm may occur. In case of such alarms, take one of the following measures:

- Reduce the torque limit values.
- Reduce the deceleration rate.
- Reduce the maximum speed.
- Install an external braking resistor if the alarm cannot be cleared using the above measures.

---

**Note**

Even you use a built-in resistor, the energy generated in some conditions will exceed the allowable capacity loss (W) of the resistor. In this case, an external braking resistor is required.

---

## 5 Model Selection

- Description of torque-speed characteristics curves:
  - Technical data and torque-speed characteristic values in the following tables are applicable to motors working with Inovance servo drives with the armature coil temperature being 20°C.
  - Continuous duty zone: Refers to a series of states in which the motor can operate safely and continuously. The actual torque must be located in this area.
  - Intermittent duty zone: Refers to a series of states in which the motor can run in a short time when the actual torque is greater than the rated torque.
- The characteristic values are obtained in cases where the motor is installed with the following heatsink (unit: mm):  
MS1H4: 250 x 250 x 6 (aluminum)
- Radial and axial loads of the motor:

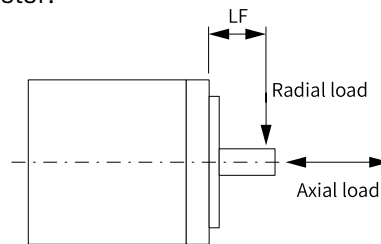

- Dimensions of flying leads motors  
The flying leads motor provides a drain wire of about 300 mm, as shown in the following figure.

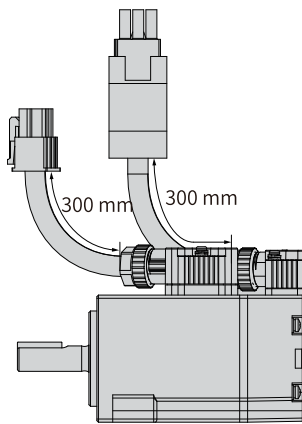

100 W motors

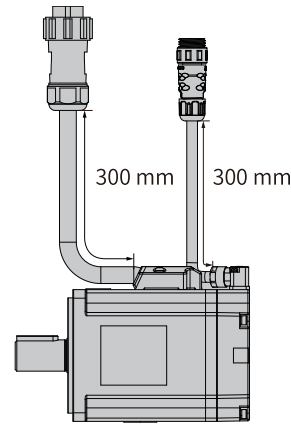

400 W and 750 W motors

### Note

- The motor with oil seal must be derated by 10% during use.
- The brake needs to be connected to an external 24 VDC power supply. The cross sectional area of DC power cables and motor brake cables must be larger than 0.5 mm<sup>2</sup>. To prevent malfunction of the brake, use a separate power supply for the brake, preventing voltage or current drop caused by other electrical devices during operation.
- Do not use a power supply for multiple brakes during use of the motor brake. Otherwise, the coil can be short-circuited after the brake is damaged due to dry friction, resulting in release failure of other brakes that connected to this power supply in parallel, which can lead to dry friction of the brake.
- The brake apply time and release time vary with the discharge circuit. Check the actual action delay of the product during use. The holding brake cannot be used for braking purpose.

## 5.1 MS1H4-10B30CA-A331R(-S) and MS1H4-10B30CA-A334R(-S)

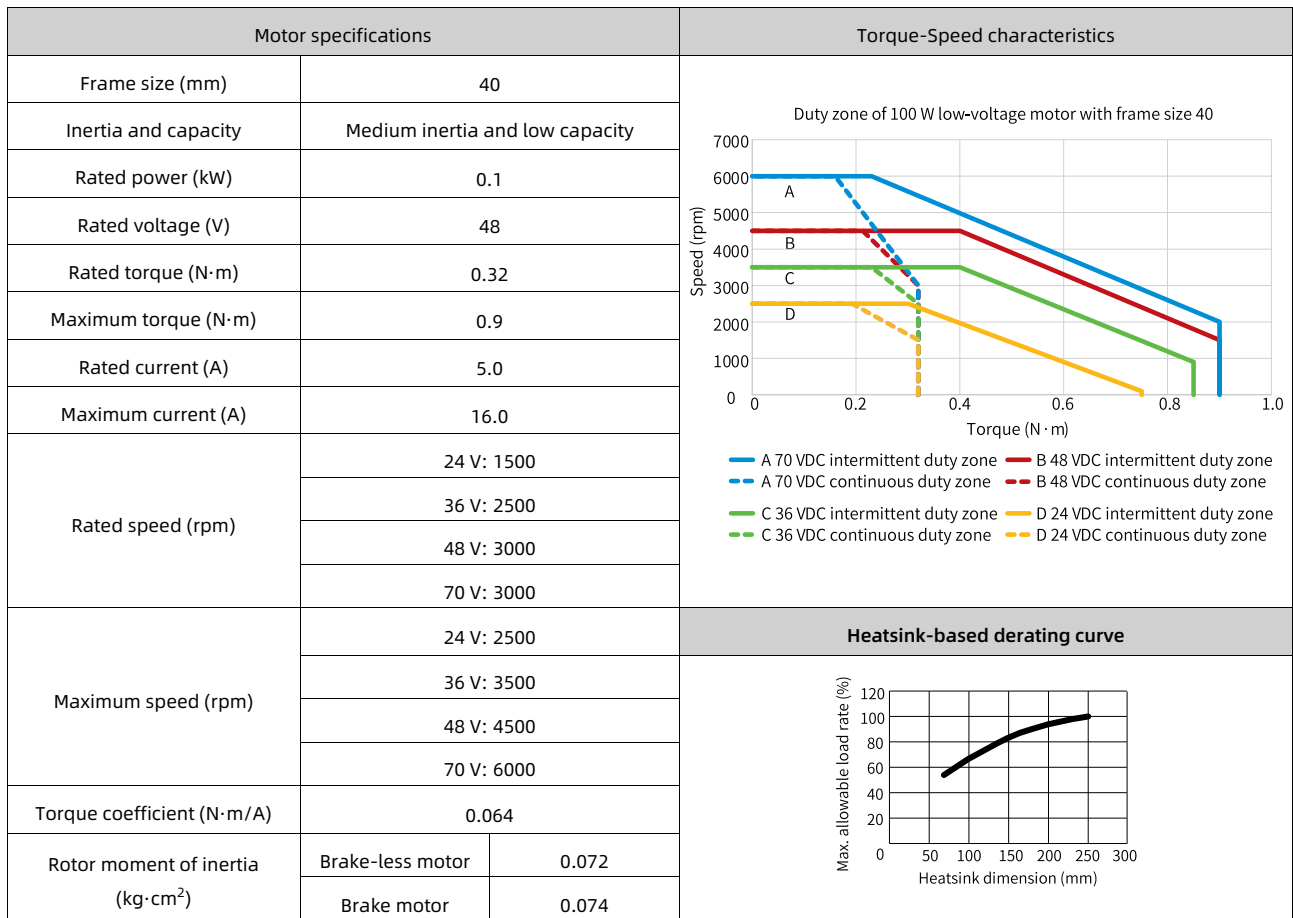

### Electrical specifications of the brake

Holding torque (N·m)	Supply voltage (VDC)±10%	Rated power (W)	Coil resistance (Ω)±10%	Excitation current (A)	Apply time (ms)	Release time (ms)	Backlash (°)
0.32	24	6.1	94.4	0.25	≤ 40	≤ 20	≤ 1.5

### Allowable load

LF (mm)	Allowable radial load (N)	Allowable axial load (N)
20	78	54

Product dimensions (mm)

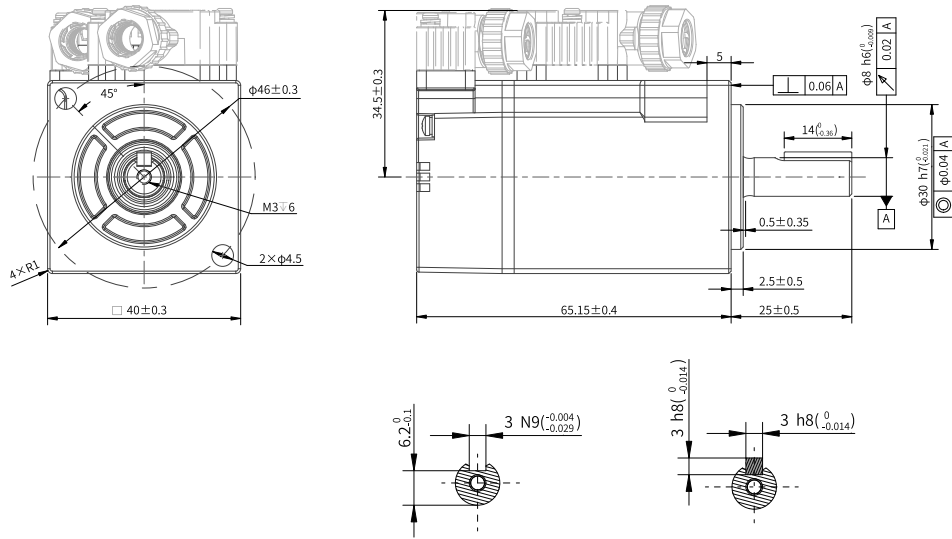

Figure 5-1 Dimensions of MS1H4-10B30CA-A331R motors

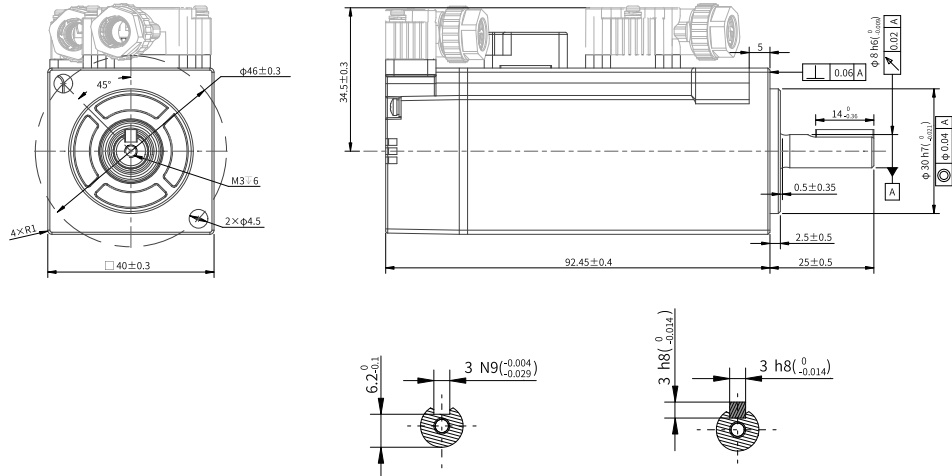

Figure 5-2 Dimensions of MS1H4-10B30CA-A334R motors

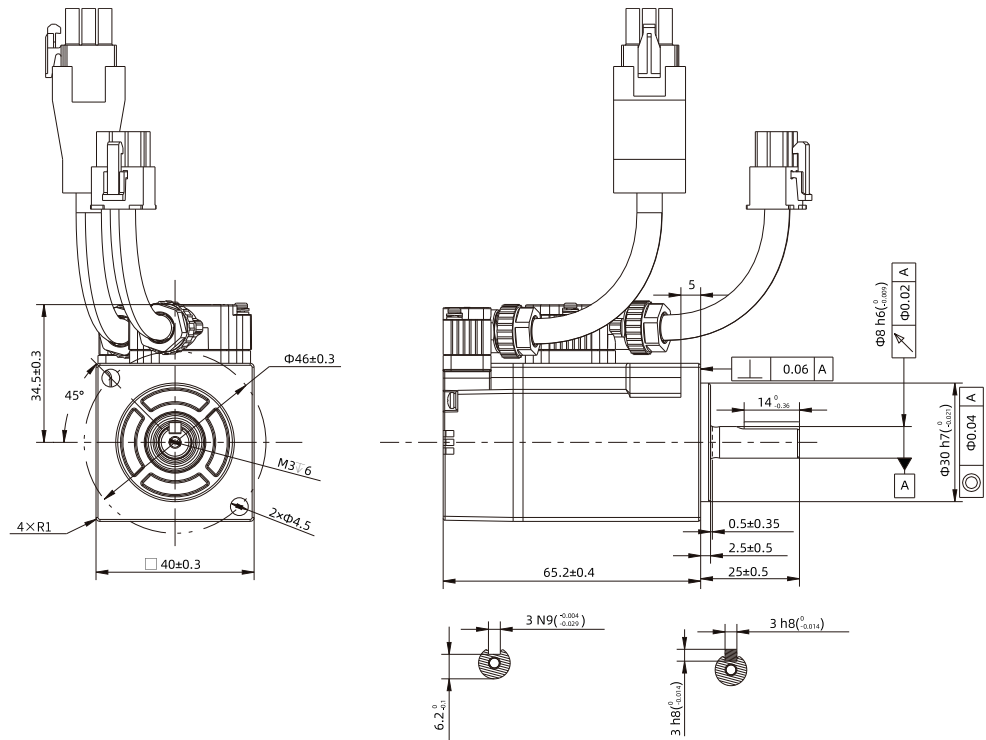

Figure 5-3 Dimensions of MS1H4-10B30CA-A331R-S motors

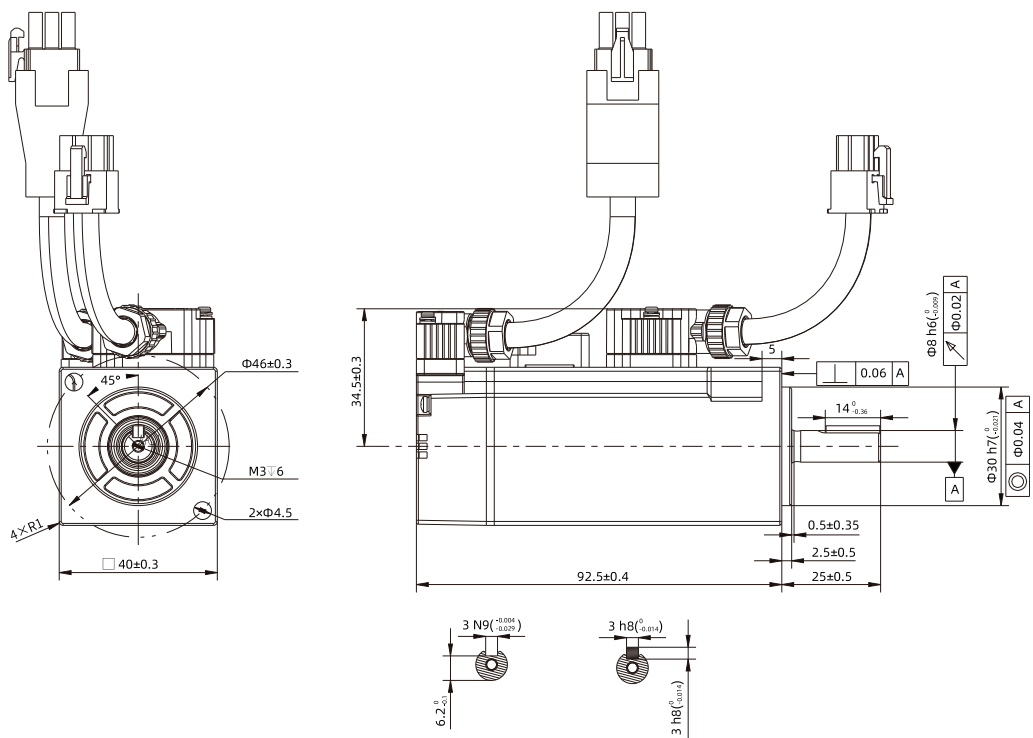

Figure 5-4 Dimensions of MS1H4-10B30CA-A334R-S motors

## 5.2 MS1H4-20B30CA-A331R and MS1H4-20B30CA-A334R

Motor specifications		Torque-Speed characteristics		
Frame size (mm)	60	<p>Duty zone of 200 W low-voltage motor with frame size</p>		
Inertia and capacity	Medium inertia and low capacity			
Rated power (kW)	0.2			
Rated voltage (V)	48			
Rated torque (N·m)	0.64			
Maximum torque (N·m)	1.7			
Rated current (A)	6.5			
Maximum current (A)	22.8			
Rated speed (rpm)	24 V: 1500			
	36 V: 2500			
	48 V: 3000			
	70 V: 3000			
Maximum speed (rpm)	24 V: 2500	<p>Heatsink-based derating curve</p>		
	36 V: 3500			
	48 V: 4500			
	70 V: 6000			
Torque coefficient (N·m/A)	0.0985			
Rotor moment of inertia (kg·cm <sup>2</sup> )	Brake-less motor			0.22
	Brake motor			0.23

### Electrical specifications of the brake

Holding torque (N·m)	Supply voltage (VDC)±10%	Rated power (W)	Coil resistance (Ω)±10%	Excitation current (A)	Apply time (ms)	Release time (ms)	Backlash (°)
1.5	24	7.6	75.79	0.32	≤ 60	≤ 20	≤ 1.5

### Allowable load

LF (mm)	Allowable radial load (N)	Allowable axial load (N)
25	245	74

Product dimensions (mm)

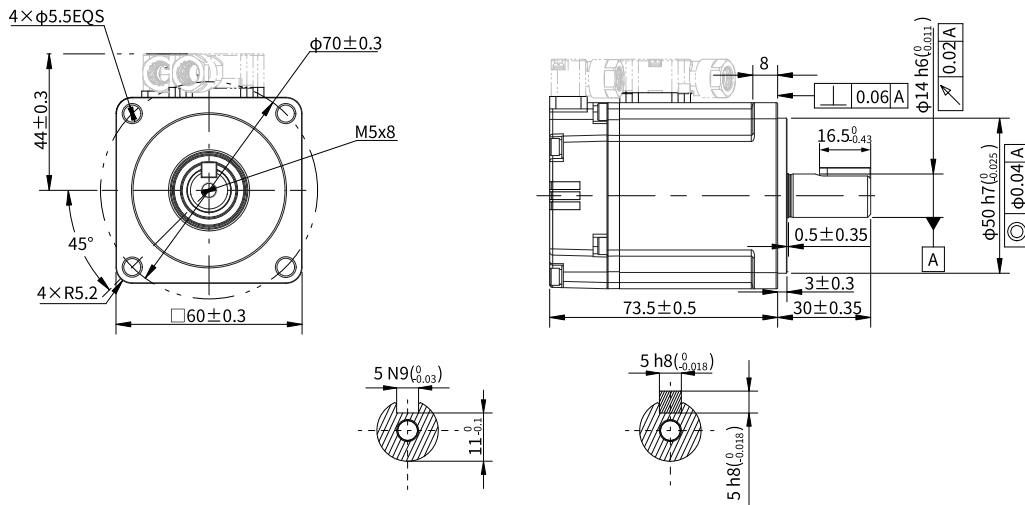

Figure 5-5 Dimensions of MS1H4-20B30CA-A331R motors

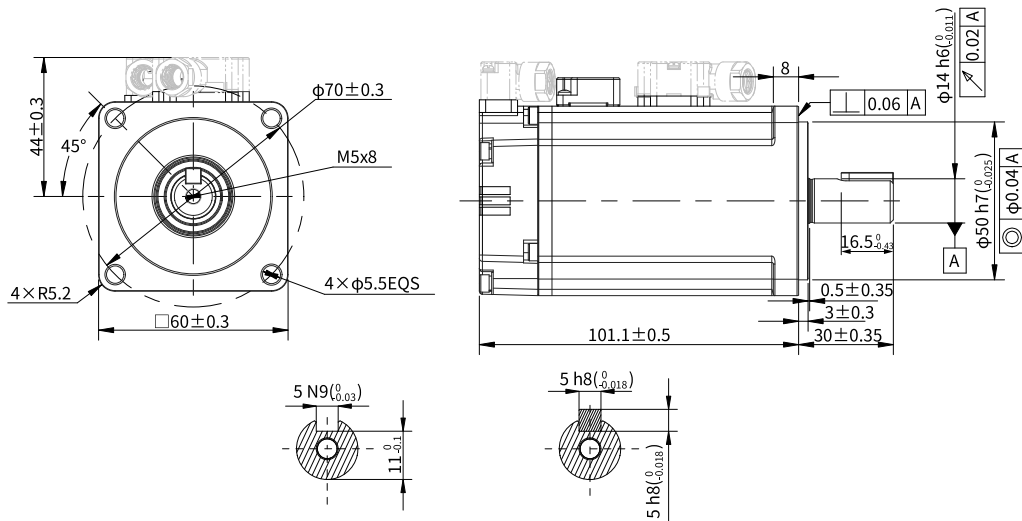

Figure 5-6 Dimensions of MS1H4-20B30CA-A334R motors

### 5.3 MS1H4-40B30CA-A331R-S and MS1H4-40B30CA-A334R-S

Motor specifications		Torque-Speed characteristics	
Frame size (mm)	60		
Inertia and capacity	Medium inertia and low capacity		
Rated power (kW)	0.4		
Rated voltage (V)	48		
Rated torque (N·m)	1.27		
Maximum torque (N·m)	3.81		
Rated current (A)	12		
Maximum current (A)	42		
Rated speed (rpm)	24 V: 900		
	36 V: 1800		
	48 V: 3000		
	70 V: 3000		
Maximum speed (rpm)	24 V: 2000		
	36 V: 3000		
	48 V: 4000		
	70 V: 6000		
Torque coefficient (N·m/A)	0.106	<b>Heatsink-based derating curve</b> 	
Rotor moment of inertia (kg·cm <sup>2</sup> )	Brake-less motor		
	Brake motor	0.44	

#### Electrical specifications of the brake

Holding torque (N·m)	Supply voltage (VDC)±10%	Rated power (W)	Coil resistance (Ω)±10%	Excitation current (A)	Apply time (ms)	Release time (ms)	Backlash (°)
1.5	24	7.6	75.79	0.32	≤ 60	≤ 20	≤ 1.5

#### Allowable load

LF (mm)	Allowable radial load (N)	Allowable axial load (N)
25	245	74

Product dimensions (mm)

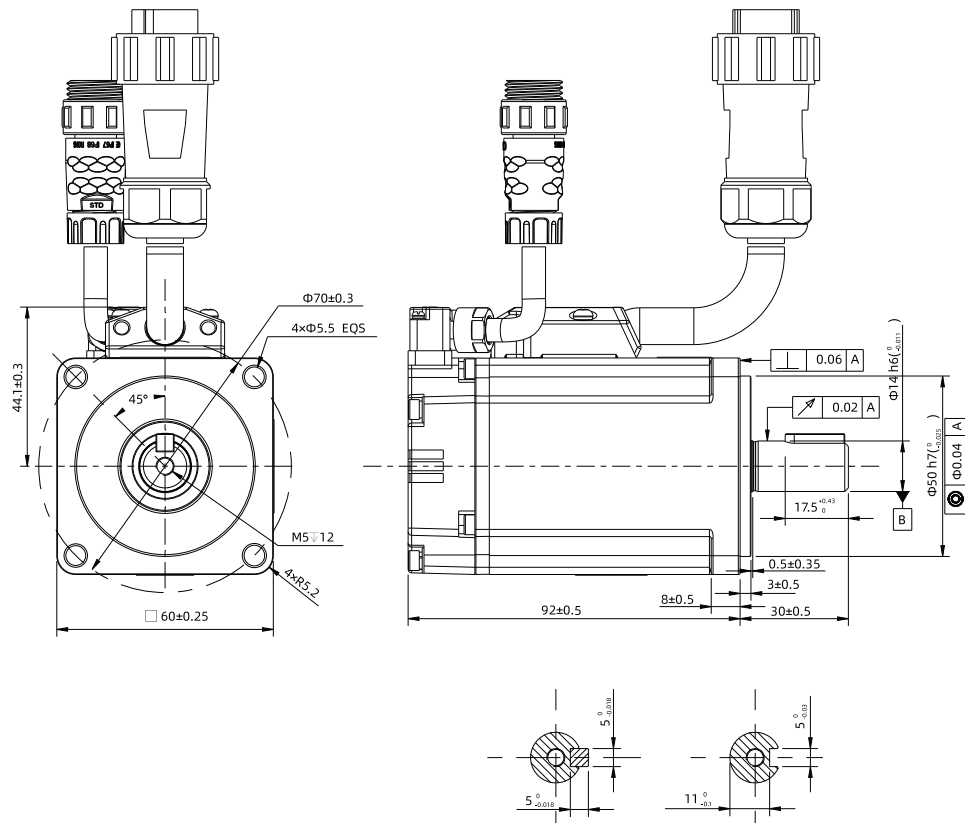

Figure 5-7 Dimensions of MS1H4-40B30CA-A331R-S motors

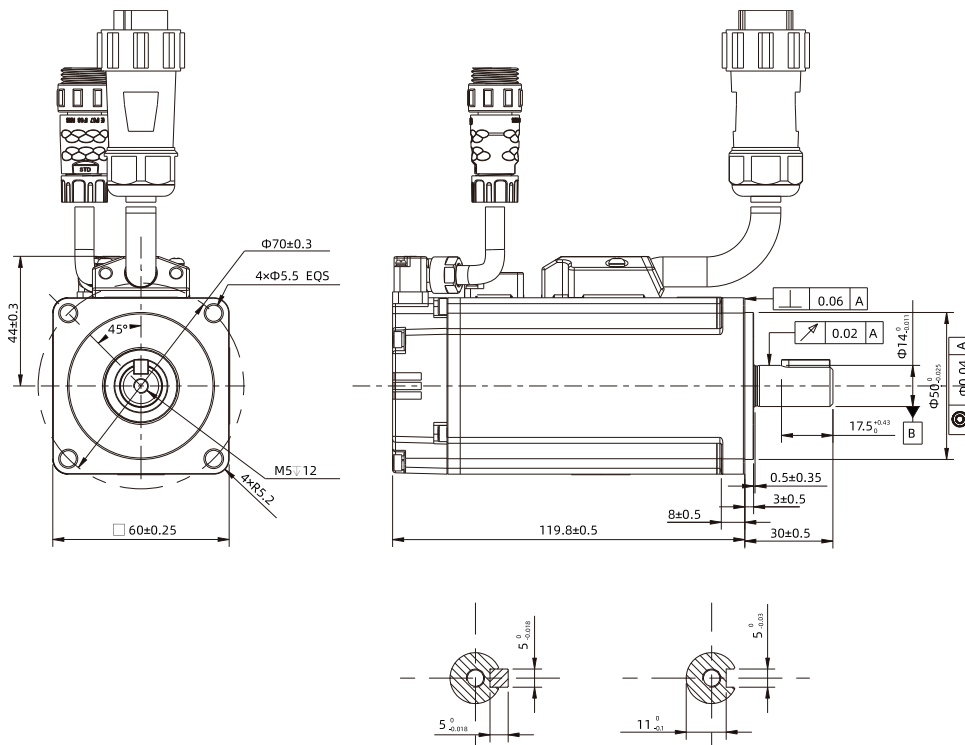

Figure 5-8 Dimensions of MS1H4-40B30CA-A334R-S motors

## 5.4 MS1H4-75B30CA-A331R-S and MS1H4-75B30CA-A334R-S

Motor specifications		Torque-Speed characteristics		
Frame size (mm)	80	<p>Duty zone of 750 W low-voltage motor with frame 80</p> <p>Speed (rpm)</p> <p>Torque (N·m)</p> <p>— A 70 VDC intermittent duty zone — B 48 VDC intermittent duty zone                      - - A 70 VDC continuous duty zone - - B 48 VDC continuous duty zone                      — C 36 VDC intermittent duty zone — D 24 VDC intermittent duty zone                      - - C 36 VDC continuous duty zone - - D 24 VDC continuous duty zone</p>		
Inertia and capacity	Medium inertia and low capacity			
Rated power (kW)	0.75			
Rated voltage (V)	48			
Rated torque (N·m)	2.39			
Maximum torque (N·m)	6			
Rated current (A)	23			
Maximum current (A)	63			
Rated speed (rpm)	24 V: 1000			
	36 V: 1800			
	48 V: 3000			
	70 V: 3000			
Maximum speed (rpm)	24 V: 2000	<p><b>Heatsink-based derating curve</b></p> <p>Max. allowable load rate (%)</p> <p>Heatsink dimensions (mm)</p>		
	36 V: 3000			
	48 V: 4000			
	70 V: 5000			
Torque coefficient (N·m/A)	0.104			
Rotor moment of inertia (kg·cm <sup>2</sup> )	Brake-less motor			1.46
	Brake motor			1.51

### Electrical specifications of the brake

Holding torque (N·m)	Supply voltage (VDC)±10%	Rated power (W)	Coil resistance (Ω)±10%	Excitation current (A)	Apply time (ms)	Release time (ms)	Backlash (°)
3.2	24	10	57.6	0.42	≤ 60	≤ 40	≤ 1

### Allowable load

LF (mm)	Allowable radial load (N)	Allowable axial load (N)
35	392	147

Product dimensions (mm)

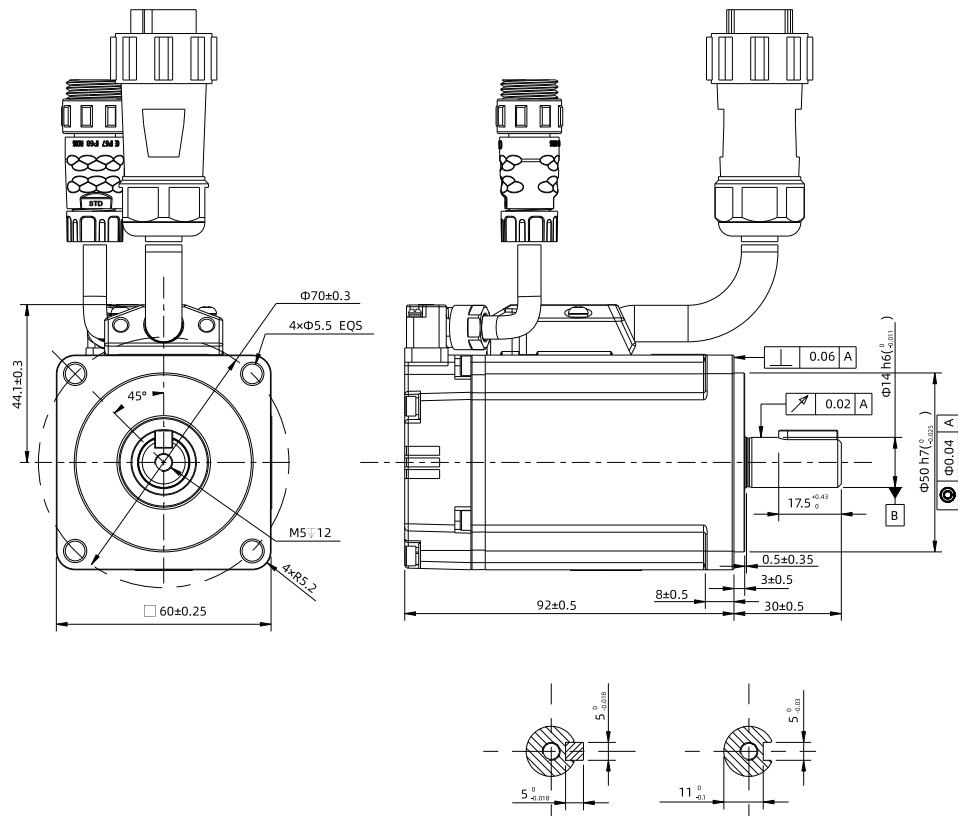

Figure 5-9 Dimensions of MS1H4-75B30CA-A331R-S motors

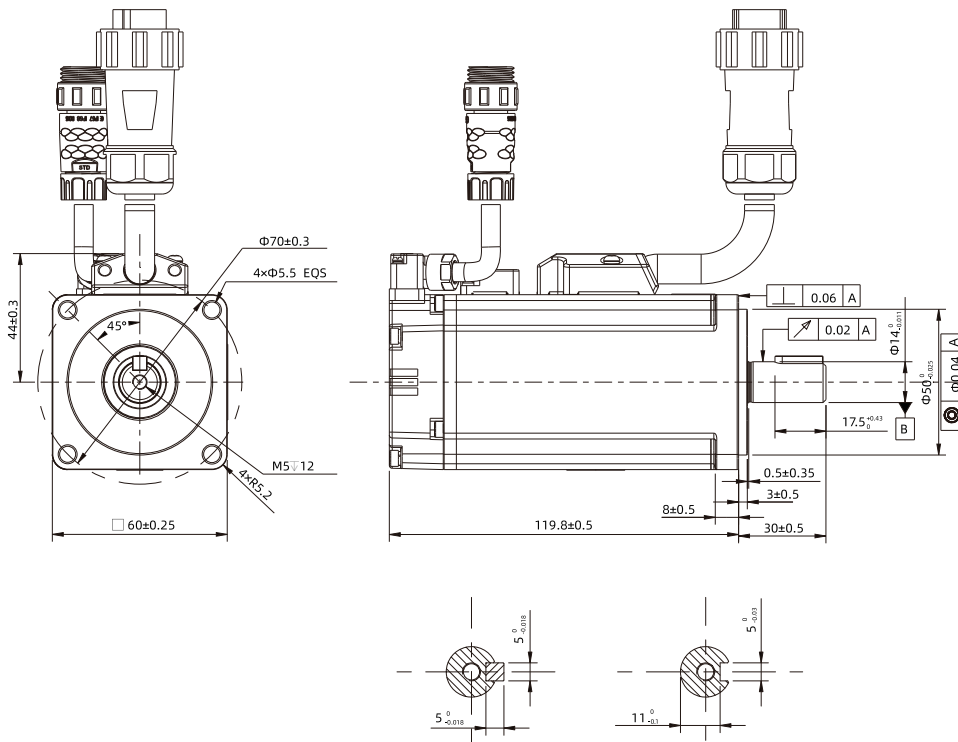

Figure 5-10 Dimensions of MS1H4-75B30CA-A334R-S motors

## 6 Cable Selection

### 6.1 Model Description

#### Power cable model

S6-L-M 0 0 0 - 3.0 - T - X  
① ②③④ ⑤ ⑥ ⑦

<p>① <b>Cable type</b></p> <p>S6-L-B/M: Motion control power cable</p> <p>B: With brake</p> <p>M: Without brake</p>	<p>④ <b>Connector type at motor end</b></p> <p>0: 6-pin plastic connector</p> <p>1: 9-pin aviation connector</p> <p>2: 6-pin aviation connector</p> <p>7: SDC-06T series aviation connector (front outlet)</p> <p>8: SDC-06T series aviation connector (rear outlet)</p> <p>C: WEIPU SP21 6-pin aviation connector</p>	<p>⑤ <b>Cable length (m)</b></p> <p>3.0: 3 m</p> <p>5.0: 5 m</p> <p>10.0: 10 m</p>
<p>② <b>Connector type at drive end</b></p> <p>0: U-shaped cable lug</p> <p>1: Pin-shaped cable lug</p>		<p>⑥ <b>Special requirements</b></p> <p>_ : Regular cable</p> <p>T: Flexible cable ≥ 10 million bending cycles</p> <p>S: Shielded</p> <p>TS: Shielded flexible cable ≥ 10 million bending cycles</p>
<p>③ <b>Cable size (mm<sup>2</sup>)</b></p> <p>9: 4 x 16AWG</p> <p>B: 4 x 12AWG</p> <p>C: 4 x 12 + 2 x 24AWG</p> <p>D: 4 x 16 + 2 x 24AWG</p>		<p>⑦ <b>Non-standard configuration or brand</b></p> <p>OR: Oil-resistant</p>

#### Description of encoder cable model

S6-L-P 0 0 0 - 3.0 - T - X  
① ②③④ ⑤ ⑥ ⑦

<p>① <b>Cable type</b></p> <p>S6-L-P: Motion control encoder cable</p>	<p>③ <b>Encoder</b></p> <p>1: Communication-type incremental encoder</p> <p>2: Communication-type multi-turn absolute encoder</p>	<p>⑤ <b>Cable length (m)</b></p> <p>3.0: 3</p> <p>5.0: 5</p> <p>10.0: 10</p>
<p>② <b>Connector type at drive end</b></p> <p>0: DB9</p> <p>1: USB</p>	<p>④ <b>Connector type at motor end</b></p> <p>0: 9-pin plastic connector</p> <p>1: 9-pin aviation connector</p> <p>4: SDC-06T series aviation connector (front outlet)</p> <p>5: SDC-06T series aviation connector (rear outlet)</p> <p>M: 10-core male connector - Chogori</p>	<p>⑥ <b>Special requirements</b></p> <p>_ : Regular cable</p> <p>T: Flexible cable ≥ 10 million bending cycles</p>
		<p>⑦ <b>Non-standard configuration or brand</b></p> <p>DC: Battery</p> <p>OR: Oil-resistant</p>

For detailed encoder cable models, see “[Encoder cable](#)” on page 36.

## Model of communication cables

S6-L-T  $\frac{01}{①}$  -  $\frac{3.0}{③}$

① Cable type	② Communication cable connection type	③ Cable length (m)
S6-L-T: Motion control communication cable	01: Multi-drive communication cable (CAN&485)	3.0: 3
	02: Drive to PLC communication cable	5.0: 5
	03: Termination resistor cable (CAN&485) for servo drive communication	10.0: 10

For detailed communication cable models, see “[Communication cables](#)” on page 37.

## 6.2 Cable Type

### Fixed cables

Do not bend or move fixed cables during use. Bending or moving fixed cables may damage the cables and lead to a series of cable-related faults such as poor contact. Secure fixed cables through fixed binding. Certain bending radius must be available to prevent excessive stress on cables.

Recommended bending radius  $\geq 5D$  (D: cable diameter)

### Flexible cables

Flexible cables can move along with cable carriers without a high risk of abrasion.

Recommended bending radius  $\geq 10D$  (D: cable diameter)

---

### Note

- Do not wind or twist the cables in the cable carrier.
  - Ensure the cable can move within the bending radius. Do not move the cables forcibly. Check that a relative movement between cables or between the cable and the guiding device is allowed.
  - Do not fix or bundle the cables inside the cable carrier. The cables can be bundled and fixed only at two unmovable ends of the cable carrier.
- 

### Oil-resistant cables

Inovance oil-resistant cables are suitable for machine tools, cutting fluids, cutting oils and other scenarios.

### More information

Terminal-type motor power cables and encoder cables must be connected with special equipment and tools. Therefore, purchase the cables through channels authorized by Inovance.

For more cable information, see cable specifications and models of the related servo drive.

### 6.3 Applicable Cable List

#### Power cable

Motor type	Cable name		Cable model	Cable length (mm)	Drawing
Terminal-type motor	Front outlet	Without brake	S6-L-M107-3.0	3100	
			S6-L-M107-5.0	5100	
			S6-L-M107-10.0	10100	
		With brake	S6-L-B107-3.0	3100	
			S6-L-B107-5.0	5100	
			S6-L-B107-10.0	10100	
	Rear outlet	Without brake	S6-L-M108-3.0	3100	
			S6-L-M108-5.0	5100	
			S6-L-M108-10.0	10100	
		With brake	S6-L-B108-3.0	3100	
			S6-L-B108-5.0	5100	
			S6-L-B108-10.0	10100	
100 W flying leads motor	Without brake	S6-L-M100-3.0	3100		
		S6-L-M100-5.0	5100		
		S6-L-M100-10.0	10100		
	With brake	S6-L-B100-3.0	3100		
		S6-L-B100-5.0	5100		
		S6-L-B100-10.0	10100		
400 W flying leads motor	Without brake	S6-L-M19C-3.0	3100		
		S6-L-M19C-5.0	5100		
		S6-L-M19C-10.0	10100		
	With brake	S6-L-B1DC-3.0	3100		
		S6-L-B1DC-5.0	5100		
		S6-L-B1DC-10.0	10100		
750 W flying leads motor	Without brake	S6-L-M1BC-3.0	3100		
		S6-L-M1BC-5.0	5100		
		S6-L-M1BC-10.0	10100		
	With brake	S6-L-B1CC-3.0	3100		
		S6-L-B1CC-5.0	5100		
		S6-L-B1CC-10.0	10100		

Encoder cable

Motor type	Cable name		Cable model	Cable length (mm)	Drawing
Terminal-type motor	Front outlet	Single-turn absolute	S6-L-P114-3.0	3000	
			S6-L-P114-5.0	5000	
			S6-L-P114-10.0	10000	
		Multi-turn absolute	S6-L-P124-3.0-DC	3000	
			S6-L-P124-5.0-DC	5000	
			S6-L-P124-10.0-DC	10000	
	Rear outlet	Single-turn absolute	S6-L-P115-3.0	3000	
			S6-L-P115-5.0	5000	
			S6-L-P115-10.0	10000	
		Multi-turn absolute	S6-L-P125-3.0-DC	3000	
			S6-L-P125-5.0-DC	5000	
			S6-L-P125-10.0-DC	10000	
100 W flying leads motor	Single-turn absolute	S6-L-P110-3.0	3000		
		S6-L-P110-5.0	5000		
		S6-L-P110-10.0	10000		
	Multi-turn absolute	S6-L-P120-3.0	3000		
		S6-L-P120-5.0	5000		
		S6-L-P120-10.0	10000		
400 W and 750 W flying leads motors	Single-turn absolute	S6-L-P11M-3.0	3000		
		S6-L-P11M-5.0	5000		
		S6-L-P11M-10.0	10000		
	Multi-turn absolute	S6-L-P11M-3.0-DC	3000		
		S6-L-P11M-5.0-DC	5000		
		S6-L-P11M-10.0-DC	10000		

## Communication cables

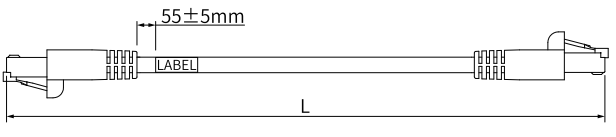
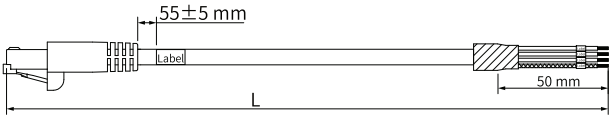
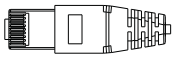
Cable name	Cable model	Cable length (mm)	Drawing
Multi-drive communication cable	S6-L-T01-0.3	300	
Servo drive to PLC communication cable	S6-L-T02-2.0	2000	
Servo drive termination resistor connector	S6-L-T03-0.0	-	

## 6.4 Cable Terminals

### 6.4.1 Power Cable Terminals

Keep the drain wire of the motor cable shield as short as possible, with its width no shorter than 1/5 of its length.

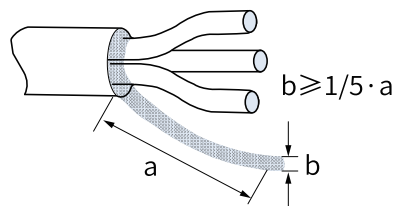

Figure 6-1 Drain wire of the motor cable shield

- The following figure shows the wiring diagram for a terminal type motor.

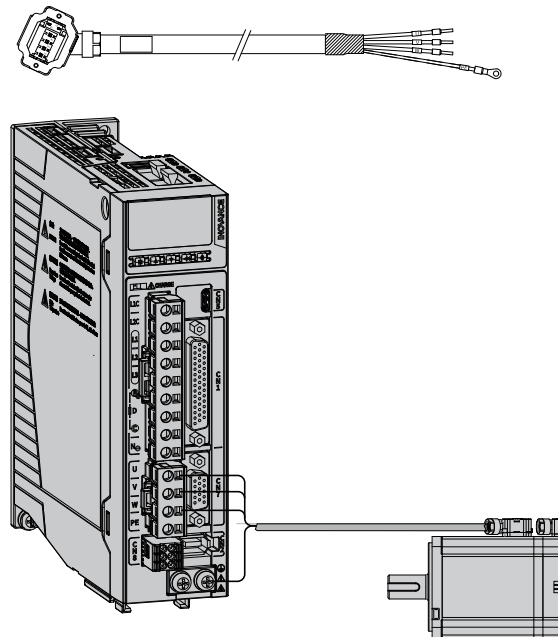
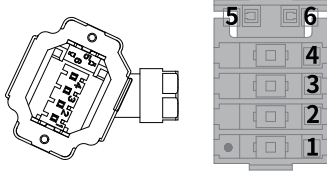

Figure 6-2 Wiring between the drive and motor

Table 6-1 Power cable connector (motor side)

Applicable motor power	Drawing of the connector	Pin layout		
		Pin No.	Name	Color
100 W 200 W	 <p>Black 6-pin connector</p>	1	PE	Yellow/Green
		2	W	Red
		3	V	Black
		4	U	White
		5	Brake (polarity insensitive)	Brown
		6		Blue

**Note**

Power cable colors are subject to the actual product. All cable colors mentioned in this guide refer to Inovance cable colors.

- The connection diagram for a flying leads motor is shown in the following figure.

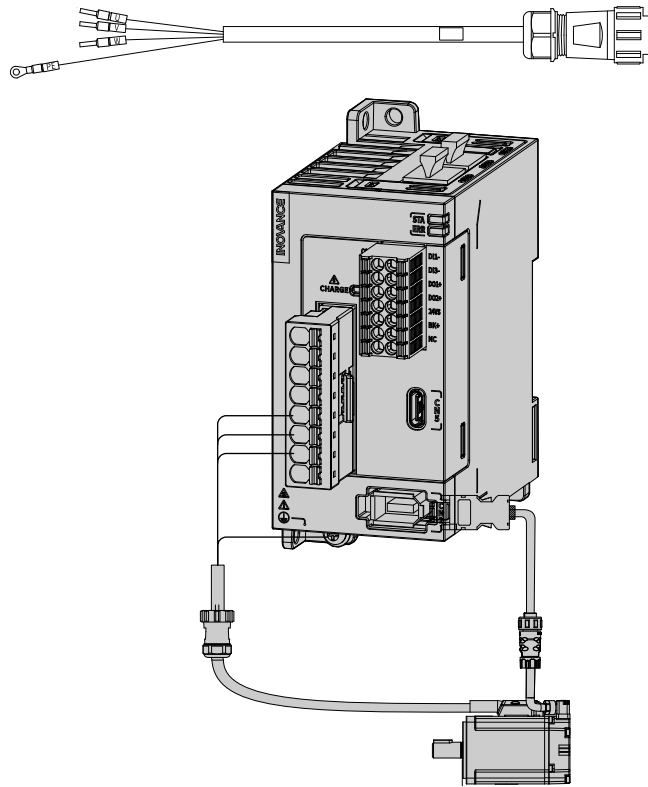

Figure 6-3 Wiring between the drive and motor

Table 6-2 Power cable connector (motor side)

Applicable motor power	Drawing of the connector	Pin layout		
		Pin No.	Name	Color
100 W	 Black 6-pin connector Recommended: plastic enclosure: MOLEX-50361736 Terminal: MOLEX-39000061	1	U	White
		2	V	Black
		4	W	Red
		5	PE	Yellow/Green
		3	Brake (polarity insensitive)	Brown
		6		Blue
400 W 750 W	 6-pin connector Recommended: WEIPU - Socket SP2111/S6	1	U	Blue
		2	V	Black
		3	W	Red
		4	PE	Yellow
		5	Brake (polarity insensitive)	Red
		6		Black

Table 6-3 Description of the power cable connector (tightening torque)

Name	Tightening torque for the body (N·m)	Tightening torque for the tail nut (N·m)
WEIPU SP2111	1.0 to 1.1	1.0 to 1.1

**Note**

Power cable colors are subject to the actual product. All cable colors mentioned in this guide refer to Inovance cable colors.

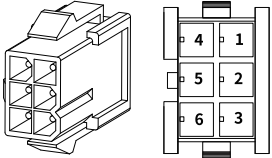
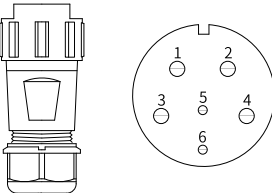
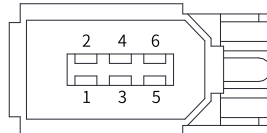
**6.4.2 Encoder Cable Terminals****Terminal layout**

Encoder signal terminal CN2 (drive side)

Figure 6-4 Layout of encoder terminal pins

Table 6-4 Description of encoder terminal pins

Pin No.	Assignment	Description
1	+5V	5 V power supply
2	GND	
3	Reserved	-
4	Reserved	-
5	PS+	Encoder signal
6	PS-	
Enclosure	PE	Shield

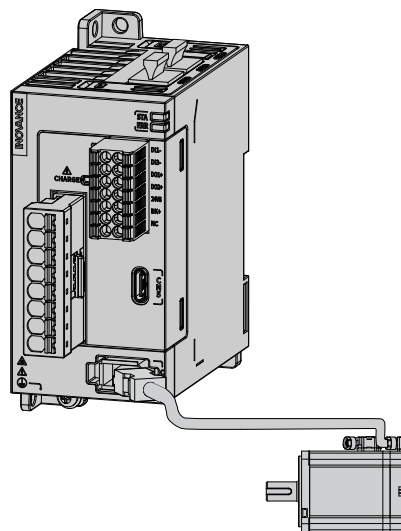
**Description**Figure 6-5 Wiring example of absolute encoder signals<sup>[1]</sup>

**Note**

- [1] The preceding figure shows the wiring of a 23-bit multi-turn absolute encoder.
- The encoder cable color is subject to the color of the actual product. Cable colors mentioned in this guide all refer to Inovance cables.

The following figure describes the drain wire color of the battery box.

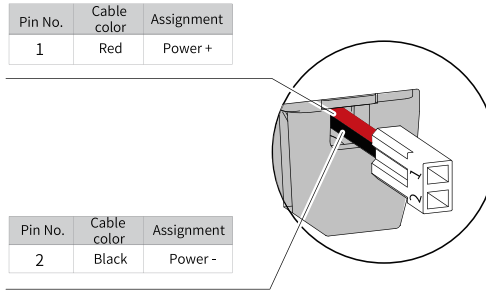

Figure 6-6 Drain wire color of the battery box

**Note**

- Keep the battery in environments within the required ambient temperature range and ensure the battery is in reliable contact and carries sufficient power capacity. Otherwise, encoder data loss may occur.
- Battery model: ER14505-1S1PA

Table 6-5 Cable connector for terminal-type motor encoder

Applicable motor power	Drawing of the connector		Pin layout			
			Pin No.	Name	Color	Type
100 W 200 W	Drive side	 <p>6-pin male (right side as the joint face)</p>	1	+5V	Red	Twisted pair
			2	GND	Orange	
			5	PS+	Blue	Twisted pair
			6	PS-	Purple	
		Enclosure	PE	-	-	
	Motor side	 <p>7-pin connector</p>	1	PS+	Blue	Twisted pair
			2	PS-	Purple	
3			DC+	Brown	Twisted pair	
4			DC-	Black		
5	+5V	Red	Twisted pair			
6	GND	Orange				
7	PE	-	-			

Table 6-6 Cable connector for flying leads motor encoder

Applicable motor power	Drawing of the connector		Pin layout			
			Pin No.	Name	Color	Type
100 W	Drive side	 <p>6-pin male (right side as the joint face)</p>	1	+5V	Red	Twisted pair
			2	GND	Orange	
			5	PS+	Blue	Twisted pair
			6	PS-	Purple	
			Enclosure	PE	-	-
	Motor side	 <p>9-pin connector</p> <p>Recommended: Plastic enclosure: AMP 172161-1; Terminal: AMP 770835-1</p>	1	Battery (+)	Brown	Twisted pair
			4	Battery (-)	Black	
			3	PS+	Blue	
			6	PS-	Purple	
			9	+5V	Red	-
8			GND	Orange		
7			Shield	-		
400 W 750 W	Drive side	 <p>6-pin male (right side as the joint face)</p>	1	+5V	Red	Twisted pair
			2	GND	Orange	
			5	PS+	Blue	Twisted pair
			6	PS-	Purple	
			Enclosure	PE	-	-
	Motor side	 <p>10-pin connector</p> <p>Recommended: Chogori 22010211-02</p>	1	PS+	Blue	Twisted pair
			2	PS-	Purple	
			5	DC+	Brown	Twisted pair
			6	DC-	Black	
			7	+5V	Red	Twisted pair
			8	GND	Orange	
			9	PE	-	

## 7 Installation Preparation

### 7.1 Installation Environment

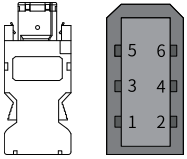
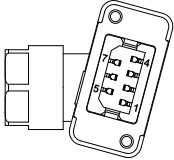
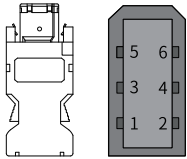
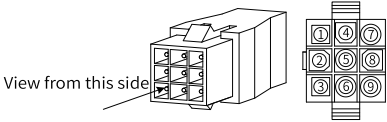
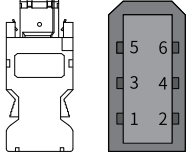
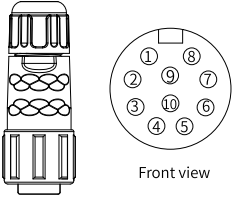
Item	Requirement
Altitude	Below 1000 m (Derating is required for altitudes above 1000 m.) <a href="#">“4.3 Derating Characteristics” on page 21</a>
Ambient temperature	0°C to 40°C (non-frozen)
Storage temperature	-20°C to +60°C
Ambient humidity	20% to 80% RH (without condensation)
Storage humidity	20% to 80% RH (without condensation)
Vibration class	V15 <sup>[1]</sup>
Vibration resistance <sup>[2]</sup> <sup>[4]</sup>	Vibration acceleration (flange face as standard), 49 m/s <sup>2</sup> in radial direction and 24.5 m/s <sup>2</sup> in axial direction
Shock resistance <sup>[3][4]</sup>	490 m/s <sup>2</sup> (flange face as standard), number of shocks: 2
IP rating	After wiring is done, the overall IP rating of the motor is as follows: IP67 (excluding shaft opening and flying leads type motor connectors)
Installation location	<ul style="list-style-type: none"> <li>• Install the motor in a place free from corrosive and inflammable gases and combustible materials, such as the hydrogen sulfide, chlorine, ammonia, sulphur gas, chloridize gas, acid, soda and salt.</li> <li>• Use the motor with oil seal in places with grinding fluid, oil mist, iron powders or cuttings.</li> <li>• Install the motor away from heating sources such as a heating stove.</li> <li>• Do not use the motor in an enclosed environment. Running in an enclosed environment can lead to motor over-temperature, which shortens its service life.</li> <li>• The X-RAY absorbed dose in the installation site must be lower than 100 rad (silicone)/25 rad (air).</li> </ul>

#### Note

- [1] Vibration class V15 indicates that the vibration amplitude is lower than 15 µm when the motor is operating at rated speed.
- [2] The vertical, side-to-side, and front-to-back resistance for vibration in three directions when the servo motor is mounted with the shaft in a horizontal position is shown in the preceding table.
- [3] The resistance for shock in the vertical direction when the servo motor is mounted with the shaft in a horizontal position is shown in the preceding table.
- [4] The vibration intensity applied on the motor is affected by the transmission structure, alignment accuracy, mounting conditions, and external vibration. These factors may enhance the vibration applied on the motor. When the maximum allowable vibration limit is exceeded, the motor may fail. Therefore, take necessary measures to limit resonance.

### 7.2 Installation Personnel

The product/system described in this manual can only be operated by qualified professionals, with operations compliant with related documents, in particular its warning notices and safety instructions. Qualified professionals can identify the risks of the product/system and prevent possible dangers.

All the mechanical operations can only be executed by trained professionals that not only familiar with the installation position, mechanical installation, troubleshooting/maintenance, but also meet the following requirements:

- Received safety training and passed related examinations or received training on mechanical operations (such as mechanical engineers or electrical engineers)
- Familiar with electrical equipment and basic mechanical characteristics and installation requirements of the motor
- Physically qualified for mechanical operations
- Familiar with this manual especially all the safety precautions

All the electrical operations can only be executed by trained professionals that not only familiar with the installation position, mechanical installation, troubleshooting/maintenance, but also meet the following requirements:

- Received professional electrical training (such as electrical engineers)
- Familiar with this manual especially all the safety precautions

---

### **Note**

Do not touch live parts. Failure to comply can lead to severe injury or even death.

- Operations on the electrical equipment can be performed by professionals only.
  - Observe local safety regulation during operation.
- 

## **7.3 Installation Tools**

Standard tools: gloves, Phillips screwdriver, straight screwdriver, Allen wrench, and torque wrench

Tools and auxiliary materials needed during installation are shown below.

Tool	Remarks
Torque wrench or screwdriver with self-locking function	Used to install the screws.
Needle-nose pliers	Used to disassemble the shaft key.
Crimping plier	Used to crimp the connectors.
Vernier caliper, micrometer, and tensometer	Used to connect the USB device.
Slip-proof gloves	Used to protect the installation personnel during installation.
Detergent	Used to remove the oily dirt.

---

### **Note**

Improper screwdrivers or tightening torque may damage the screws on the equipment.

- Use a screwdriver that matches the screw head.
  - Tighten the screws with specified tightening torque.
  - Use a torque wrench or sensor with dynamic torque and mechanical high-precision screwdriver with speed limit.
-

## 7.4 Installation Precautions

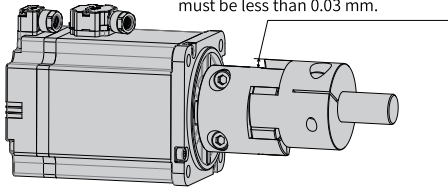
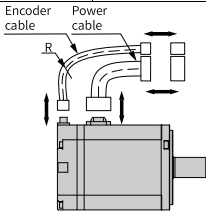
Item	Description				
Alignment	<p>Use the coupling for mechanical connection and align the axis center of the servo motor with the axis center of the machine. When installing the servo motor, make sure the alignment accuracy requirement shown in the following figure is fulfilled. Failure to comply will result in vibration that may damage the bearing and encoder.</p> <p>In the following figure, the ex-circle of half the coupling that fixed to the motor end is taken as the basis for measuring the distance from the basis to any four points of the left end of the other half coupling in peripheral direction. The difference of the maximum and minimum values measured must be below 0.03 mm.</p> <p>Measure the distance at four different positions on the circumference. The difference between the maximum and minimum measured values must be less than 0.03 mm.</p> 				
Stress of cables	<p>Do not bend or pull the cable with excessive force, especially the signal wires whose conductors are only 0.2 mm or 0.3 mm in thickness.</p> <p>The minimum bending radius of the cable must meet the following requirements.</p> <table border="1" data-bbox="652 947 1433 1021"> <tr> <td data-bbox="652 947 959 985">Regular cables</td> <td data-bbox="959 947 1433 985">R = 5 x cable diameter</td> </tr> <tr> <td data-bbox="652 985 959 1021">Flexible cables</td> <td data-bbox="959 985 1433 1021">R = 10 x cable diameter</td> </tr> </table> 	Regular cables	R = 5 x cable diameter	Flexible cables	R = 10 x cable diameter
Regular cables	R = 5 x cable diameter				
Flexible cables	R = 10 x cable diameter				
Connector	<p>Pay attention to the following precautions:</p> <ul style="list-style-type: none"> <li>• Ensure there are no unwanted objects such as waste or sheet metal inside the connector.</li> <li>• Connect the connector to the main circuit cable side of the servo motor first, and ensure the grounding cable of the main circuit cable is connected reliably. If the connector is firstly connected to the encoder cable side, the encoder may become faulty due to the potential difference between PEs.</li> <li>• Ensure the pins are correctly arranged during wiring.</li> <li>• The connector is made of resin. Do not strike the connectors to prevent them from being damaged.</li> <li>• When transporting the servo motor with motor cables connected, hold the servo motor by its body instead of cables. Failure to comply may damage the connector and the cable.</li> <li>• If flexible cables are used, do not apply stress to connectors during wiring. Failure to comply may damage the connector.</li> </ul>				





## 8 Unpacking and Handling

### 8.1 Unpacking

#### Unpacking precautions

- Pay attention to the handling icons on the package after receiving the motor.

Handling icons and their definitions:

Icon	Definition	Icon	Definition
	Upwards		Moisture-proof
	Fragile		No stacking

- Check whether all the products ordered are received.
  - Check whether the products received comply with the delivery note.
  - Contact the carrier immediately if you found any obvious sign of damage.
  - Contact Inovance office immediately if you found any parts missing.
  - The manual Safety Instructions for High-Response Servo Motors is within the scope of delivery. Keep it properly for future use.

#### Note

- Claims exceeding the deadline will not be accepted.
- Do not use damaged components.
- Observe local regulations when packing and handling the motor.

#### Unpacking inspection

Check the following items upon unpacking.

Item	Description
Check whether the delivered product is consistent with your order.	Check whether the motor model and specifications comply with your order. <b>Note:</b> Check whether the packing box is intact. If the packing box is damaged, contact your supplier immediately.
Check whether the product is intact.	Check whether the product delivered is in good condition. If there is any missing or damage, contact Inovance or your supplier immediately.

## 8.2 Handling

Observe related handling regulations and use proper grasping device or hold the motor by hands during handling. The motor may be damaged by improper operation during handling or installation. Operating on a damaged motor may damage the winding, bearing, or even the whole system.

## 8.3 Storage

Pack the motor into the original package if possible. Apply protective coating on the exposed shaft end, sealing components, and flange face. Store the motor in a dry, dust-free, and vibration-free place indoors. This is to prevent the motor from being affected by extreme weather factors. The motor can be stored for at most two years in temperatures between -20°C to +60°C. An excessively long storage time can affect the characteristics of the lubricating grease on the rolling bearing. Equipment damage caused by failure to comply with the preceding requirements is not covered by warranty.

The place where the motor is stored for more than six months must meet the following requirements.

Table 8-1 Storage environment condition

Item	Description
Ambient temperature	-20°C to +60°C
Maximum relative humidity	< 60% (without condensation)
Mechanical environment	Stable and vibration-free, $V_{\text{valid}} < 0.2 \text{ mm/s}$ The X-RAY absorbed dose of the storage site must be lower than 100 rad (silicone)/25 rad (air).

Check whether the motor state every six months:

- Check whether the motor suffers from moisture through detecting the insulation resistance (detection voltage: 500 VDC).
- Check whether connectors and fasteners are corroded and whether the sealing parts are intact.
- Perform necessary maintenance.
- Check the desiccant state and replace it if necessary.
- Make a record of the storage operations for the convenience of future use.

The insulation resistance is related to the temperature. If the insulation resistance is excessively low after long-term storage, take desiccation measures on the motor, such as dry the motor with hot air.

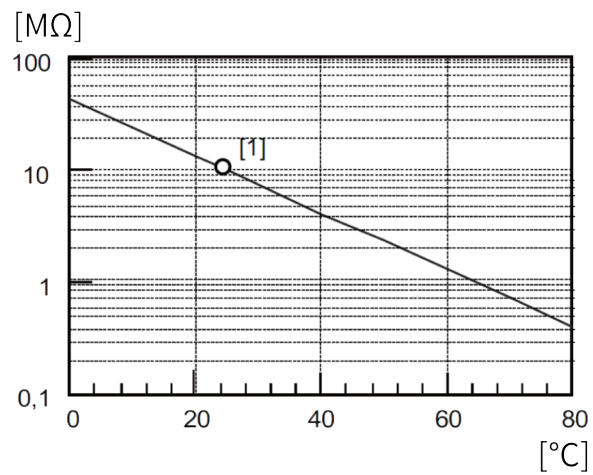

Figure 8-1 Relation between insulation resistance and temperature

---

**Note**

The following environment conditions may easily lead to water condensation:

- Dramatic temperature change;
- Direct sunlight;
- High temperature during storage;

Put a desiccant into the package and avoid preceding conditions.

---

# 9 Wiring

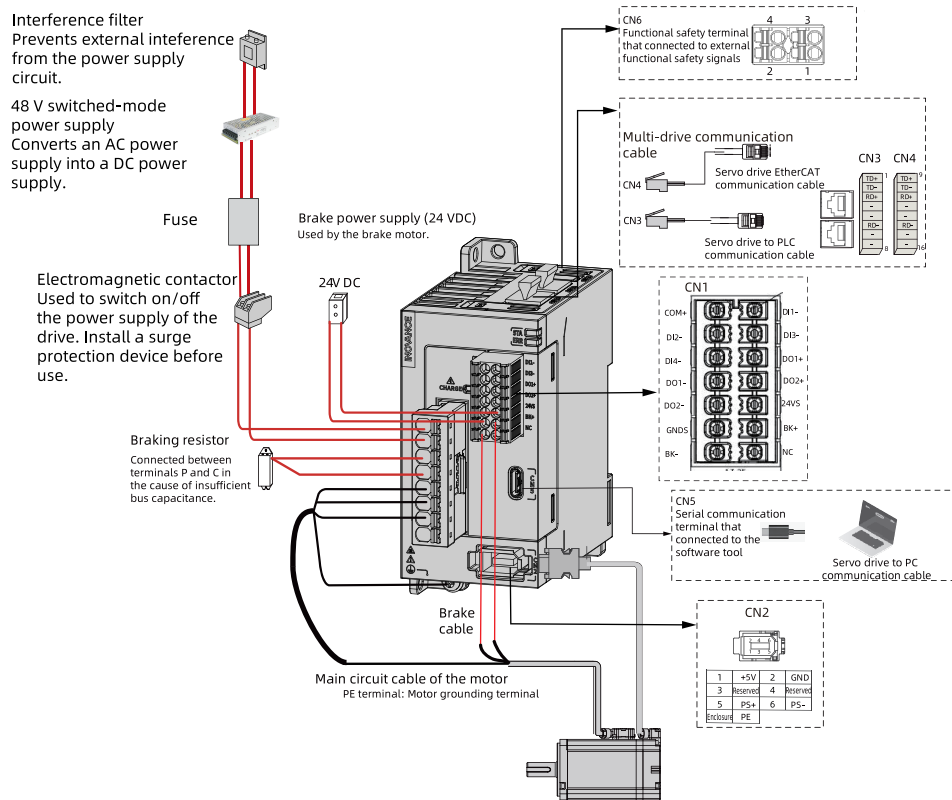

Figure 9-1 System wiring diagram

## 10 Maintenance Interval

To keep the servo drive and servo motor in good condition, perform maintenance regularly based on the following table. Contact Inovance or Inovance agent to check whether parts replacement is needed.

Item	Name	Standard interval	Remarks
Motor	Absolute encoder battery	Depends on the operating condition. See the operation instructions for the encoder battery for details.	If any device/component works improperly, replace it immediately.
	Insulation resistance	Check the insulation resistance at least once per year.	Use a insulation resistance gauge (set to 500 VDC) to measure the insulation resistance. Measurement method: Measure the resistance between the PE (grounding) and any phase among U/V/W. The resistance measured should be higher than 10 MΩ.
Equip-ment	Overall inspection	Perform overall inspection at least once every five years or every 20,000 hours, whichever comes first.	Perform maintenance based on the related maintenance guide of the equipment.

# 11 Maintenance

## 11.1 Routine Maintenance

Standard operating conditions:

Average annual ambient temperature < 30°C, daily operating time < 20 h

### 11.1.1 Routine Checklist

Check the following items during routine inspection.

Table 11-1 Routine checklist

No.	Item	Compliance
1	The ambient temperature and humidity are normal. There is no dust or unwanted objects in the motor.	<input type="checkbox"/>
2	There is no unusual vibration or noise.	<input type="checkbox"/>
3	The voltage of the power supply is normal.	<input type="checkbox"/>
4	There is no strange smell.	<input type="checkbox"/>
5	There are no fibers adhered to the air vent.	<input type="checkbox"/>
6	There is no intrusion of unwanted objects on the load end.	<input type="checkbox"/>

### 11.1.2 Routine Cleaning

Perform routine cleaning based on the following table.

Table 11-2 Routine cleaning list

No.	Routine cleaning list	Compliance
1	Clean the dust, especially the metal dust on the surface of the equipment.	<input type="checkbox"/>
2	Keep the front end of the servo drive and the connectors clean.	<input type="checkbox"/>
3	The service life of the bearing may be reduced when the motor rotates forwardly/reversely continuously at an angle lower than 150°. Therefore, rotate the motor shaft for more than one revolution at least once a day.	<input type="checkbox"/>

#### Note

- Before cleaning, switch off the power supply and clean with an air gun or a piece of dry cloth.
- Do not use gasoline, dilutes, alcohol, or acid or alkaline detergent to prevent enclosure discolor or damage.

## 11.2 Regular Checklist

Table 11-3 Regular checklist

No.	Regular checklist	Compliance
1	Check that the screws used to fix the couplings between devices are in place.	<input type="checkbox"/>
2	There is no sign of overtemperature.	<input type="checkbox"/>

---

No.	Regular checklist	Compliance
3	Terminal blocks are in good condition without any sign of damage.	<input type="checkbox"/>
4	The clamping units of terminal blocks are in place.	<input type="checkbox"/>

## 12 Certifications and Standards

### CE certification

Directive	Standard	
EMC Directive 2014/30/EU	Servo drive	EN 61800-3
	Servo motor	EN 61800-6-2 EN 61800-6-4 EN 55011
Low Voltage Directive 2014/35/EU	Servo drive	EN 61800-5-1
	Servo motor	EN 60034-1 EN 60034-5
RoHS Directive 2011/65/EU 2015/863/EU	Servo drive	EN 50581
	Servo motor	

### UL/cUL certification

Certification	Standard	
UL/cUL	Servo drive	UL61800-5-1 C22.2 No.274-17
	Servo motor	UL 1004-1 UL 1004-6 CSA C22.2 No. 100-14

---

### Note

The product complies with the latest version of directives and standards for CE and UL/cUL certifications.

---

## 13 Service and Support

### 13.1 Service and Support

Should you encounter a safety accident during the use or operation of the product, or face challenges in operating and maintaining the equipment, which remain unresolved after the relevant documentation is consulted, we provide multiple channels to ensure prompt resolution:

- Channel #1: Contact [service@inovance.com](mailto:service@inovance.com).
- Channel #2: Visit <https://www.inovance.com/global> to access document downloads, after-sales support, spare parts ordering, repair applications, and authenticity verification services.
- Channel #3: Download My Inovance app (<https://zshc-eu.inovance.com/download-pc/>) where you can access products info and documentation, and query product parameters.

We are committed to providing you with quick and professional technical support, and we look forward to your satisfaction and trust.



Copyright © Shenzhen Inovance Technology Co., Ltd.

PS00011274A03

---

**Shenzhen Inovance Technology Co., Ltd.**

[www.inovance.com](http://www.inovance.com)

---

**Suzhou Inovance Technology Co., Ltd.**

[www.inovance.com](http://www.inovance.com)

---

Add.: Inovance Headquarters Tower, High-tech Industrial Park,  
Guanlan Street, Longhua New District,  
Shenzhen 518000, P.R. China

Tel: (0755) 2979 9595

Fax: (0755) 2961 9897

---

Add.: No. 52, Tian E Dang Road, Wuzhong District, 215104,  
Suzhou City, Jiangsu Province, P.R. China

Tel: (0512) 6637 6666

Fax: (0512) 6285 6720