



**MAC1403M2-GAAJEPB**

Int.ServoAC 1500WS1 4.78Nm IP55 Inc EP 2xHvD



**General information**

**Description** Int.ServoAC 1500WS1 4.78Nm IP55 Inc EP 2xHvD, WxHxL: 80.5x120.3x199.5 mm. 3000 RPM. 4.78 Nm RMS / 14.33 Nm Peak, 48 VDC supply, IP55, Incremental magnetic 8192 CPR , 3000 RPM, - isolated ground, Color: Black, Ø19x40 mm with Keyway 6x6x25 mm, Built in Profinet. 4xM12. 2x4pF:Profinet 17pF:8xIOA +RS422+RS485, 2x Heavy duty DC power connectors

<b>Manufacture</b>	JVL	<b>Motor type</b>	Integr. AC-servo - Rotating
<b>Main supply [V]</b>	48	<b>Voltage type - Main</b>	DC
<b>Motor power [W]</b>	1500	<b>Power Peak [W]</b>	4500
<b>Duty Cycle</b>	S1	<b>Max Duty Cycle [%]</b>	100
<b>Continuous Torque</b>	4.78	<b>Peak torque [Nm]</b>	14.33
<b>Speed [Rpm]</b>	3000	<b>Speed Max. [Rpm]</b>	3600
<b>Encoder type</b>	Abs. Singleturn Encoder	<b>Encoder [Counts/rev]</b>	8192
<b>Integrated PLC</b>	Yes	<b>Brake</b>	No
<b>STO connector</b>	No	<b>Fan mounted</b>	No
<b>Integrated gear</b>	No	<b>Gear ratio</b>	-
<b>Flange size</b>	80x80		
<b>Shaft size - Front [mm]</b>	19.00mm	<b>Shaft Type Output</b>	Keyway
<b>Protection house</b>	IP55	<b>Protection shaft</b>	IP55
<b>Control voltage (CVI/O+) [VDC]</b>	18-30		
<b>PLC no. of DI/DO/AI</b>	8	<b>PLC no. of DI/DO</b>	
<b>Multifunction IOs</b>	8		
<b>Color</b>	Black		



## MAC1403M2-GAAJEPB

Int.ServoAC 1500WS1 4.78Nm IP55 Inc EP 2xHvD

### General information

<b>Software</b>	MacTalk	<b>Interface</b>	Profinet
<b>Approval - UL</b>	Pending	<b>Approval TÜV - STO</b>	No
<b>Ambient Temperature range [°C]:</b>		<b>Max. Amb. Temperature range - Torque derating:</b>	
<b>Maximum Installation Altitude [m]:</b>		<b>- Power Derating every 1000m over 1000m [%]:</b>	
<b>Weight net [kg]</b>	4.00	<b>Weight gross [kg]</b>	4.10
<b>Country Of Origin</b>	DK	<b>Tariff no</b>	85015220
<b>Tariff no US</b>			



**MAC1403M2-GAAJEPB**

Int.ServoAC 1500WS1 4.78Nm IP55 Inc EP 2xHvD

**Mechanical information**

<b>Motor type</b>	Integr. AC-servo - Rotating	<b>Color</b>	Black
<b>Rotor inertia [kgcm<sup>2</sup>]</b>	3.15	<b>Max inertia factor</b>	20
<b>Duty Cycle</b>	S1	<b>Max Duty Cycle [%]</b>	100
<b>Encoder type</b>	Abs. Singleturn Encoder	<b>Encoder [Counts/rev]</b>	8192
<b>Precision Motor - Absolute [Deg -/+]</b>	0.071	<b>Precision Motor - Max Load [Deg -/+]</b>	
<b>Precision Motor - Repeatability [Deg -/+]</b>	0.049		
<b>Brake</b>	No	<b>Brake - Go ON time [ms]</b>	-
<b>Brake Holding torque [Nm]</b>	-	<b>Brake - Go OFF time [ms]</b>	-
<b>Brake Backlash (Play)</b>			
<b>Radial load [N]</b>	335	<b>Radial load distance [mm]</b>	25
<b>Axial load [N]</b>	167		
<b>Axial play [mm]</b>	0.0	<b>Axial play force [N]</b>	147
<b>Front bearing type</b>	6004-ZZ	<b>Rear bearing type</b>	16002-ZZ
<b>Integrated gear</b>	No	<b>Gear ratio</b>	-
<b>Gear efficiency [%]</b>	< -	<b>Gear backlash [ArcMin]</b>	-
<b>Motor length [mm]</b>	199.5	<b>Motor width [mm]</b>	80.5
<b>Motor height [mm]</b>	120.3	<b>Protection house</b>	IP55
<b>Customer Sealing</b>	Standard		
<b>Flange size</b>	80x80	<b>Mounting holes front [mm]</b>	5.4
<b>Motor diameter center front [mm]</b>	70.0	<b>Bolt circle diameter front [mm]</b>	90.0
<b>Flange material</b>	Aluminium	<b>Flange Thickness [mm]</b>	8.00
<b>Shaft size - Front [mm]</b>	19.00mm	<b>Shaft Type Output</b>	Keyway
<b>Shaft length Front [mm]</b>	40.0	<b>Shaft material</b>	Steel 40Cr
<b>Shaft Key included</b>	Key included on shaft	<b>Shaft Key Dimension</b>	6x6x25
<b>Shaft Seal</b>	-	<b>Protection shaft</b>	IP55
<b>Approval - ROHS-3</b>	Yes	<b>Approval - UL</b>	Pending
<b>Approval TÜV - STO</b>	No	<b>Approval - ATEX</b>	No
<b>Datasheet - pdf</b>	No	<b>User Manual</b>	Download



## MAC1403M2-GAAJEPB

Int.ServoAC 1500WS1 4.78Nm IP55 Inc EP 2xHvD

### Mechanical information

REACH SVHC document

Download

No Dual Use

Read more here

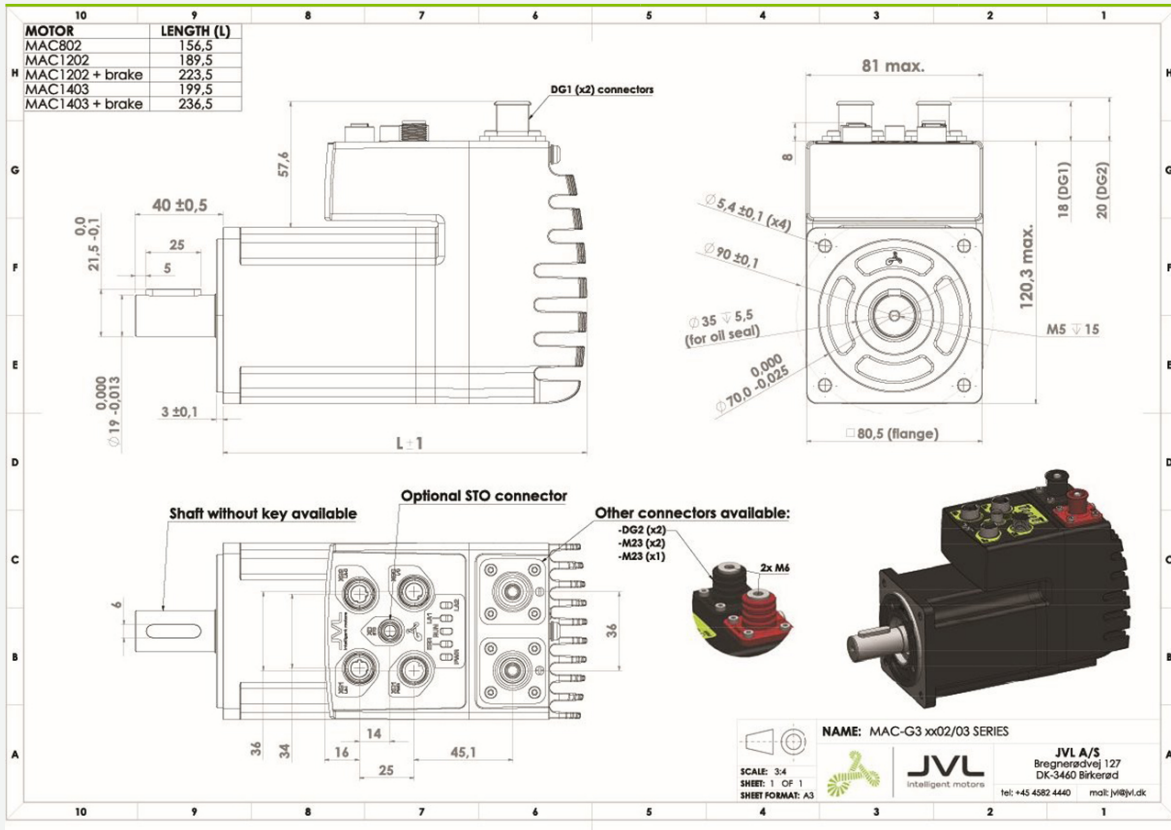

CAD 2D [PDF]

No

CAD 2D [DWG]

No

CAD 3D [DWG]

No

CAD 3D [EASM]

No

CAD 3D [IGES]

No

CAD 3D [STEP]

Download



**MAC1403M2-GAAJEPB**

Int.ServoAC 1500WS1 4.78Nm IP55 Inc EP 2xHvD

**Connector information**

**Motor connectors**

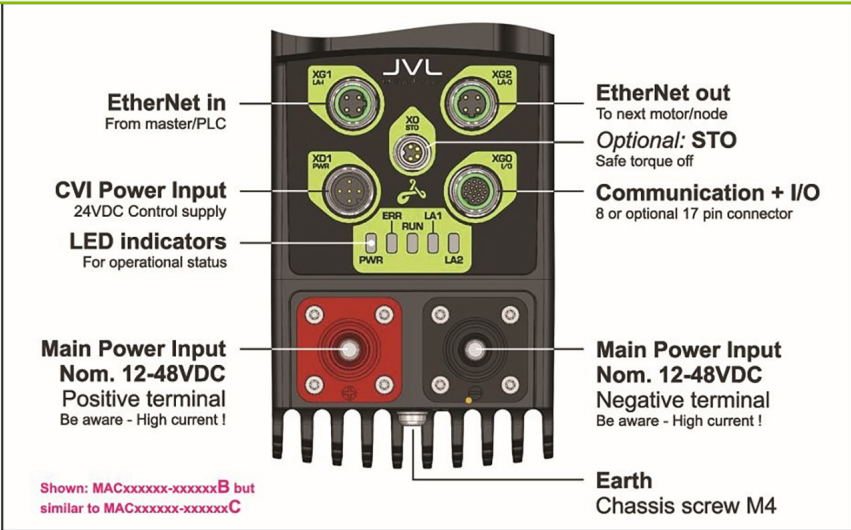

<b>Connector XD0 Description</b>	Power input: Heavy Duty Positive	<b>Connector XD0 Supplier</b>	JVL
<b>Connector XD0 Direction</b>	Straight		
<b>Connector XD1 Description</b>	Power input: Heavy Duty Negative	<b>Connector XD1 Supplier</b>	JVL
<b>Connector XD1 Direction</b>	Straight		
<b>Connector STO</b>	No	<b>STO Connector Type</b>	
<b>Connector XD10 label</b>	CVI Power Input	<b>Connector XD10</b>	M12 5-pin male A-coded
<b>Connector XG1 label</b>	Profinet in	<b>Connector XG1</b>	M12 4-pin female D-coded Ethernet
<b>Connector XG2 label</b>	Profinet out	<b>Connector XG2</b>	M12 4-pin female D-coded Ethernet
<b>Connector XG0 label</b>	Communication + I/O	<b>Connector XG0</b>	M12 17-pin female A-coded
<b>Connector XG1 RS485</b>	No	<b>Connector XG2 RS485</b>	No
<b>Connector XG0 RS485</b>	Yes		

**XD10 Pinout**

"PWR" (XD10) - Power input. M12 - 5pin male connector				
Signal name	Description	Pin no.	JVL Cable WI1000-M12F5TxxN	Isolation group
-	Not used	1	Brown	1
-	Not used	2	White	1
P-	Main supply ground. Connect with pin 5 *	3	Blue	1
CVI	Control and user output supply +7-32VDC. <b>DO NOT connect &gt;32V to this terminal!</b>	4	Black	1
P-	Main supply ground. Connect with pin 3 *	5	Grey	1

Connector housing/metal is connected to earth and at JVL supplied cables also to the cable screen.



**MAC1403M2-GAAJEPB**

Int.ServoAC 1500WS1 4.78Nm IP55 Inc EP 2xHvD

**Connector information**

**XG1 Pinout**

<b>“LA-I” (XG1) Ethernet In connector - M12 - 4pin female connector “D” coded</b>				
Signal name	Description	Pin no.	JVL Cable WI1046-M12 M4TM4TxxT	Isolation group (See note)
Tx0_P	Ethernet Transmit channel 0 - positive terminal	1	-	2
Rx0_P	Ethernet Receive channel 0 - positive terminal	2	-	2
Tx0_N	Ethernet Transmit channel 0 - negative terminal	3	-	2
Rx0_N	Ethernet Receive channel 0 - negative terminal	4	-	2

Connector housing/metal is connected to earth and at JVL supplied cables also to the cable screen.

**XG2 Pinout**

<b>“LA-O” (XG2) Ethernet Out connector M12 - 4 pin female connector “D” coded</b>				
Signal name	Description	Pin no.	JVL Cable WI1046-M12 M4TM4TxxT	Isolation group (see note)
Tx1_P	Ethernet Transmit channel 1 - positive terminal	1	-	3
Rx1_P	Ethernet Receive channel 1 - positive terminal	2	-	3
Tx1_N	Ethernet Transmit channel 1 - negative terminal	3	-	3
Rx1_N	Ethernet Receive channel 1 - negative terminal	4	-	3

Connector housing/metal is connected to earth and at JVL supplied cables also to the cable screen.

**XG0 Pinout**

<b>“I/O” (XG0) RS485 + I/O connector - M12 - 17pin female connector</b>				
Signal name	Description	Pin no.	JVL Cable WI1009M12 M17TxxN	Isolation group (see note)
IO1	I/O channel 1. Can be used as input or output 350mA	1	Brown	1
GND	Ground intended to be used together with the other signals in this connector	2	Blue	1
IO2	I/O channel 2. Can be used as input or output 350mA	3	White	1
IO3	I/O channel 3. Can be used as input or output 350mA	4	Green	1
RS422: B1-	RS422 I/O terminal B-	5	Pink	1
IO4	I/O channel 4. Can be used as input or output 350mA	6	Yellow	1
RS422: A1-	RS422 I/O terminal A-	7	Black	1
RS422: B1+	RS422 I/O terminal B+	8	Grey	1
CVO	Supply output. Connected internally to the CVI terminal in the PWR connector. <b>DO NOT connect &gt;30V to this terminal!</b>	9	Red	1
RS422: A1+	RS422 I/O terminal A+	10	Violet	1
IO5	I/O channel 5. Can be used as input or output 350mA	11	Grey/pink	1
IO6	I/O channel 6. Can be used as input or output 350mA	12	Red/blue	1
IO7	I/O channel 7. Can be used as input or output 350mA	13	White/Green	1
IO8	I/O channel 8. Can be used as input or output 350mA	14	Brown/Green	1
RS485: B0-	RS485 MacTalk interface. Leave open if unused	15	White/Yellow	1
GND	Ground intended to be used together with the other signals in this connector	16	Yellow/brown	1
RS485: A0+	RS485 MacTalk interface. Leave open if unused	17	White/grey	1

Connector housing/metal is connected to earth and at JVL supplied cables also to the cable screen.

**CON Main**

<b>“Main Power Input” - Main power for the motor - Heavy duty connectors</b>				
Signal name	Description	Pin no.	JVL Cable	Isolation group
M+	RED terminal - +12-48VDC (positive)	1	WP080x and others	4
M-	BLACK terminal - Ground (negative)	2	WP070x and others	4

Be aware that this is the main supply for the motor and these terminal is isolated from any other connector or terminals at the motor.  
The current can be up to **60ARMS** (continuously) and the up to **200A** I peak during motor acceleration.  
Be careful when dimensioning the power supply circuit and consult the power supply chapter in this manual for further details.



**MAC1403M2-GAAJEPB**

Int.ServoAC 1500WS1 4.78Nm IP55 Inc EP 2xHvD

**Torque, force and Power information**

<b>RMS torque [Nm]</b>	4.78	<b>Peak torque [Nm]</b>	14.33
<b>Supply Volt 1 [V]</b>	12	<b>Velocity max 1 [Rpm]</b>	1250
<b>Supply Volt 2 [V]</b>	24	<b>Velocity max 2 [Rpm]</b>	2000
<b>Supply Volt 3 [V]</b>	48	<b>Velocity max 3 [Rpm]</b>	3600
<b>Supply Volt 4 [V]</b>		<b>Velocity max 4 [Rpm]</b>	

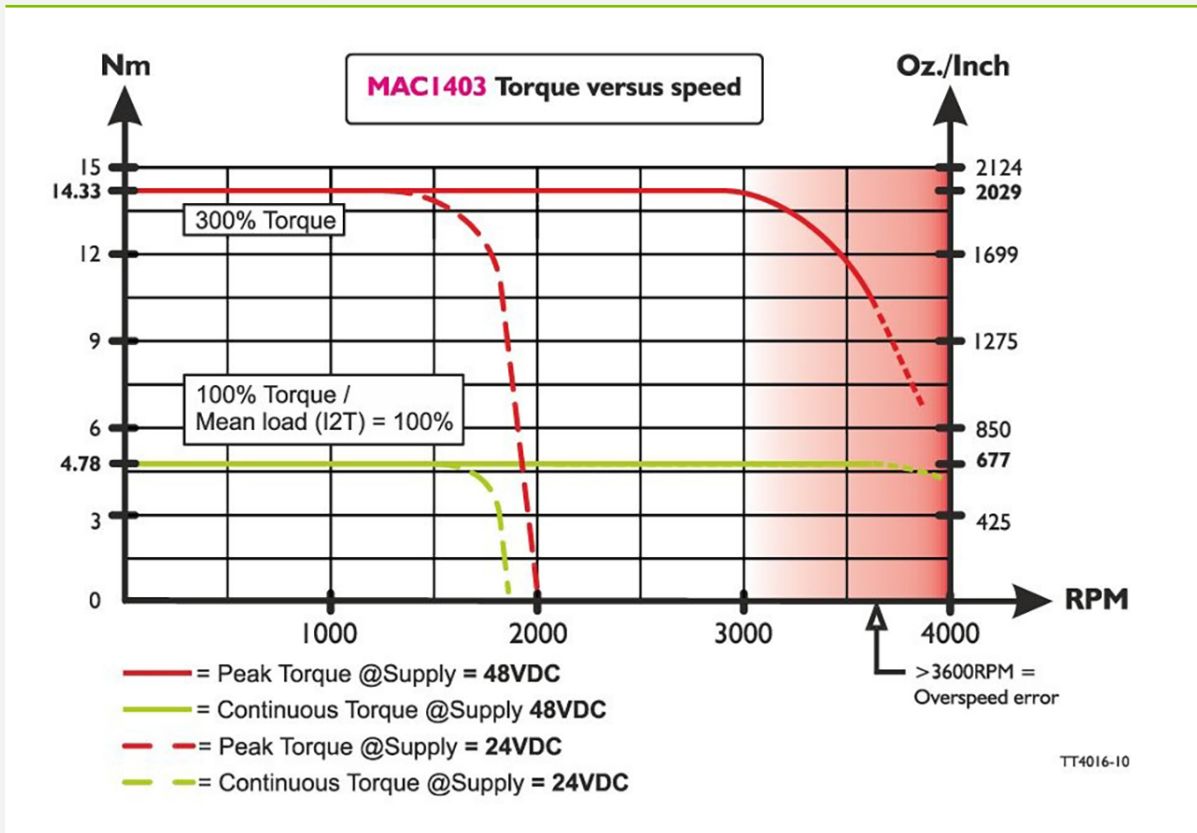



**MAC1403M2-GAAJEPB**

Int.ServoAC 1500WS1 4.78Nm IP55 Inc EP 2xHvD

**Electrical information**

<b>Main supply [V]</b>	48	<b>Main supply Min-Max [V]</b>	10-60
<b>Main Voltage possible</b>		<b>Inrush current -Main max [A]</b>	
<b>Input Voltage Frequency</b>			
<b>Recommended fuse</b>	T50A@48VDC if automatic use class D	<b>P- isolated from Earth ( Low Voltage ground (P-) isolated from housing)</b>	Yes
<b>Internal Power-Dump Resistance [Ohm]</b>	n/a	<b>Internal Power-Dump Power [W]</b>	n/a
<b>PD connection - Int/Ext</b>	Int/Ext PD in Parallel		
<b>External Power-Dump Resistance Minimum value [Ohm]</b>	n/a	<b>External Power-Dump Max Current [A]</b>	n/a
<b>Control voltage (CVI/O+) [VDC]</b>	18-30	<b>Control Voltage (CVI) Min-Max [VDC]</b>	18-32
<b>Max current CVI [A]</b>	0.25		
<b>PLC no. of DI/DO/AI</b>	8	<b>PLC no. of DI/DO</b>	
<b>Dig. Input impedans</b>	30k 0-5 V	<b>PLC DO max current [mA/DO]</b>	350
<b>PLC AIN voltage [VDC]</b>	0-5 VDC, 12 bit	<b>PLC AIN Min-Max [VDC]</b>	-10 / +30
<b>PLC AIN Max Tol. [%]</b>	±2		
<b>Multifunction IOs</b>	8	<b>PLC MF low level [VDC]</b>	-
<b>PLC MF high level [VDC]</b>	-	<b>PLC MF Max level [VDC]</b>	0-5 V -7 -> +12
<b>Temperature Error [°C]</b>			



**JVL A/S | Bregnerødvej 127 | DK-3460 Birkerød | Denmark | Tel. (+45) 4582 4440 | www.jvl.dk | sales@jvl.dk**

**MAC1403M2-GAAJEPB**

Int.ServoAC 1500WS1 4.78Nm IP55 Inc EP 2xHvD

**Communication information**

**Software** MacTalk

**Connectivity:** Profinet



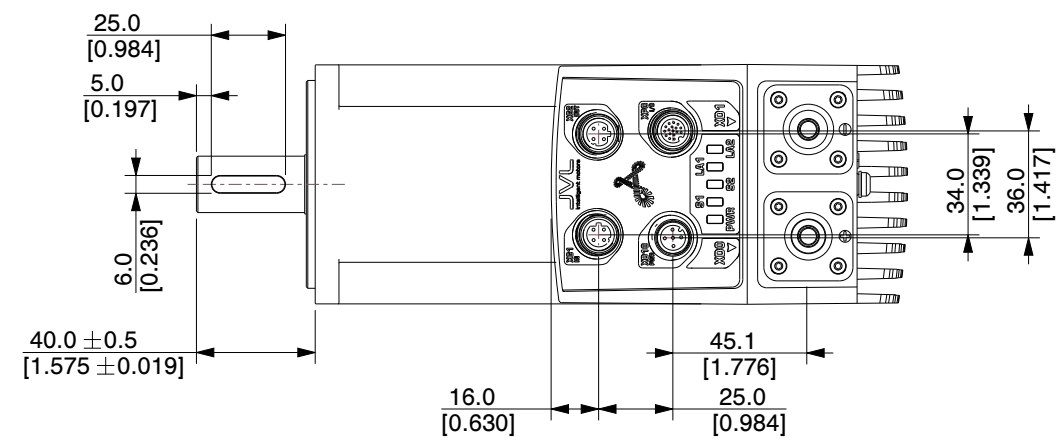
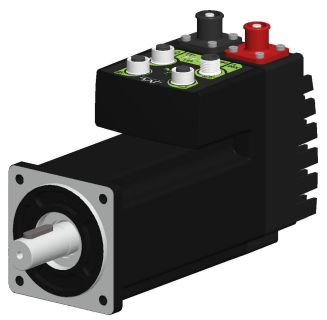
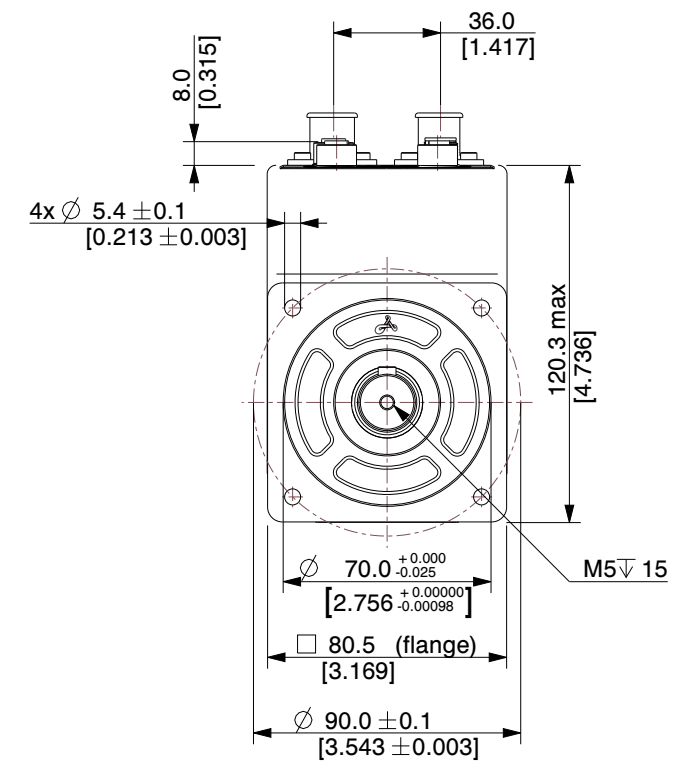
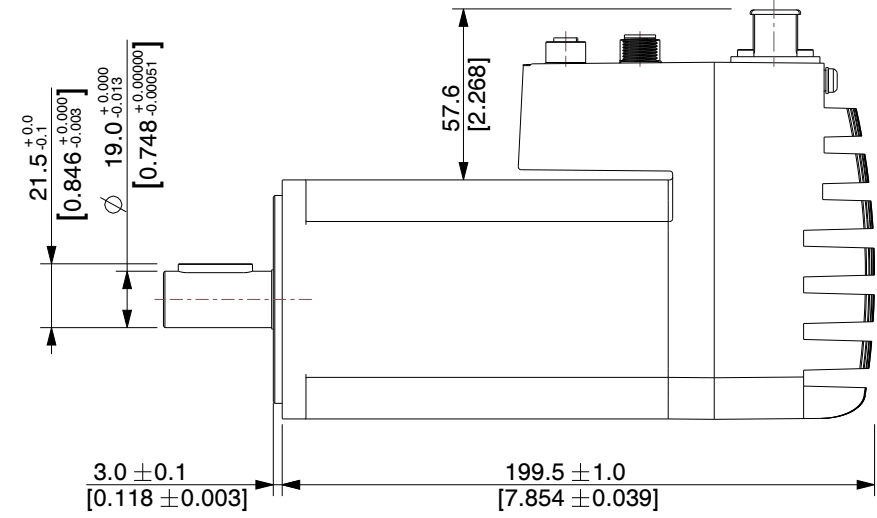
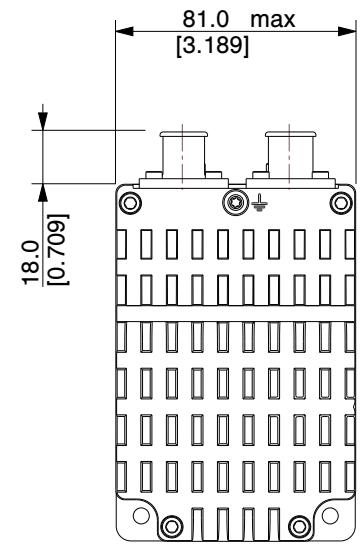

**e-PLC Files**

**Without module**

**Ethernet, PLC demo files**



**NOTES:**  
 1. Encoder Type: Absolute multturn 4096 Rev. Single 8192 CPR

<b>JVL A/S</b> Bregnerødvej 127 DK-3460 Birkerød Denmark		 	
<b>PART NUMBER:</b> <p style="text-align: center;"><b>MAC1403M2-GAAJEPB</b></p>			
<b>PART DESCRIPTION:</b> <p style="text-align: center;"><b>Integrated Stepper Motor</b></p>			
		<b>A4</b>	SCALE
			UNIT
			NTS
			MM [Inch]
<small>Unless specifically stated otherwise, this drawing is the property of JVL A/S and no feature embodied herein may be disclosed except as previously authorized</small>			