

PL/WPL series

精密 · 经济

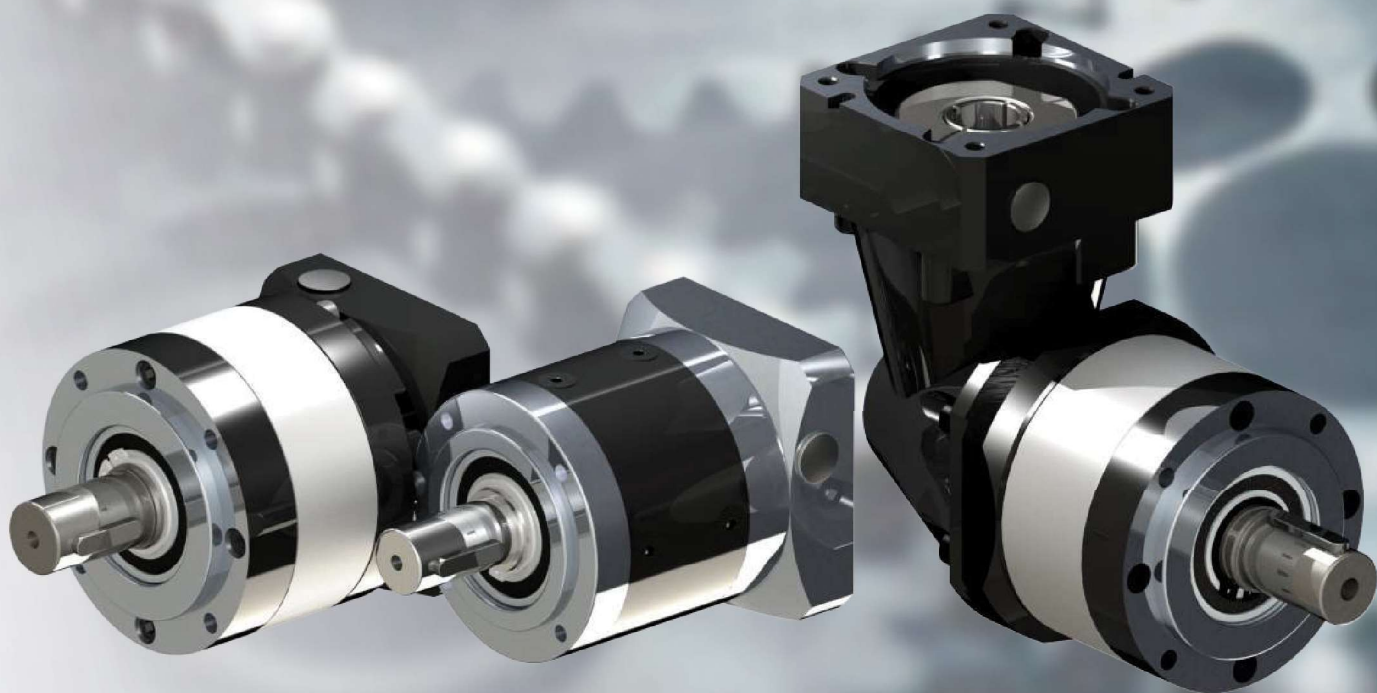

规格	节数	减速比	WPL040	WPL060	WPL080	WPL090	WPL120	WPL140	WPL160
减速比 Ratio	1	3	7.3	18.6	38	38	109	231	364
		4	13.4	34.5	73	73	207.5	452	770
		5	10	24	64	64	177.5	415	635
		6	4.7	20	55	55	128	323	432
		8	4.9	18.5	59.5	59.5	116	216	334.5
		10	—	14	41	41	65	120	192
	2	9	7.3	18.6	38	38	109	231	364
		12	13.4	34.5	73	73	207.5	452	770
		15	10	24	64	64	177.5	415	635
		16	13.4	34.5	73	73	207.5	452	770
		20	13.4	34.5	73	73	207.5	452	770
		25	10	24	64	64	177.5	415	635
		30	10	24	64	64	177.5	415	635
		32	13.4	34.5	73	73	207.5	452	770
		40	10	24	64	64	177.5	415	635
		50	10	24	64	64	177.5	415	635
		64	4.9	18.5	59.5	59.5	116	216	334.5
		80	4.9	18.5	59.5	59.5	116	216	334.5
最大加速力矩 T2B Maximum acceleration torque	Nm	1&2	详见各基座附表						
急停扭矩 T2Not Sudden stop torque	Nm	1&2	详见各基座附表						
额定输入转速 Nominal input speed	rpm	1&2	3000	3000	3000	3000	3000	3000	2000
最大输入转速 Maximum input speed	rpm	1&2	6000	6000	6000	6000	6000	6000	4000
精密背隙 Precision backlash	P1-arcmin	1	12	10	10	10	10	10	10
		2	14	12	12	12	12	12	12
	P2-arcmin	1	18	12	12	12	12	12	12
		2	20	14	14	14	14	14	14
噪音 Noise	dB(A)	1&2	60	63	65	65	68	68	70
容许最大径向负载 Maximum radial load	N	1&2	220	480	900	900	1850	2000	3600
容许最大轴向负载 Maximum axial load	N	1&2	200	600	1200	1200	2800	3500	8000
效率 Efficiency	%	1	≥95%						
		2	≥92%						
使用环境温度 Use of temperature	℃	1&2	<-15℃~+40℃>						
使用寿命 Service life	h	1&2	≥20000						
润滑 Lubrication		1&2	合成润滑脂 (终身免保养)						

AB
ADR
AD
ADR
AE
AER
AF
AFR
PN
WPN
IB
IBR
PW
PL
WPL
PF
WPF
PS
WPS
NTX

WPL 惯性力矩总表

惯性力矩 kgcm ²	速比	WPL040	WPL060			WPL080			WPL120			WPL140			WPL160		
		≤ φ8	≤ φ8	≤ φ14	≤ φ19	≤ φ14	≤ φ19	≤ φ24	≤ φ19	≤ φ24	≤ φ35	≤ φ24	≤ φ35	≤ φ42	≤ φ24	≤ φ35	≤ φ42
一段	3	0.09	0.31	0.39	0.58	2.12	2.45	4.2	6.74	8.34	15.4	23.1	27.5	40.7	23.1	27.5	40.7
	4	0.09	0.27	0.34	0.53	1.89	2.22	4.2	5.49	7.08	14.2	18.5	22.9	36.1	18.5	22.9	36.1
	5	0.09	0.25	0.32	0.51	1.8	2.13	4.2	5.02	6.61	13.7	16.9	21.2	34.5	16.9	21.2	34.5
	7	0.09	0.23	0.31	0.5	1.73	2.06	4.2	4.65	6.24	13.3	15.5	19.5	33.1	15.5	19.5	33.1
	8	0.09	0.23	0.31	0.5	1.71	2.04	4.2	4.65	6.14	13.2	15.2	19.5	32.8	15.2	19.5	32.84
	10	0.09	0.23	0.3	0.49	1.69	2.02	4.2	4.46	6.05	13.1	14.6	19	32.3	14.6	19	32.26
二段	9	0.09	0.07	0.11	0.26	0.41	0.6	2.1	2.58	4.7	7.2	8	15	20	8	15	20
	12	0.09	0.07	0.11	0.26	0.41	0.6	2.1	2.58	4.7	7.2	8	15	20	8	15	20
	15	0.09	0.07	0.11	0.26	0.46	0.6	2.1	2.58	4.7	7.2	8.88	15	20	8.88	15	20
	16	0.09	0.07	0.11	0.26	0.4	0.65	2.1	2.79	4.91	7.2	7.8	15.9	20	7.8	15.9	20
	20	0.09	0.06	0.11	0.26	0.4	0.6	2.1	2.53	4.65	7.2	7.75	15	20	7.75	15	20
	25	0.09	0.06	0.11	0.26	0.4	0.6	2.1	2.51	4.64	7.2	8.68	15	20	8.68	15	20
	30	0.09	0.06	0.11	0.26	0.4	0.6	2.1	2.2	4.33	7.2	7.75	13.6	20	7.75	13.6	20
	32	0.09	0.05	0.11	0.26	0.4	0.6	2.1	2.2	4.62	7.2	6.5	14.7	20	6.5	14.7	20
	40	0.09	0.06	0.11	0.26	0.4	0.6	2.1	2.48	4.61	7.2	6.5	13.6	20	6.5	13.6	20
	50	0.09	0.06	0.11	0.26	0.32	0.5	2.1	2.18	4.31	7.2	6.5	13.6	20	6.5	13.6	20
	64	0.09	0.06	0.11	0.26	0.32	0.5	2.1	2.18	4.31	7.2	6.5	13.6	20	6.5	13.6	20
80	0.09	0.06	0.11	0.26	0.32	0.5	2.1	2.18	4.31	7.2	6.5	13.6	20	6.5	13.6	20	

减速机订货选购说明 / Instructions for order and purchase of planetary reducer

WPL 040 L1 - 5 - P2 - S2



motor size

MODEL
系列代号

SIZE
规格

STAGE
段数 (级数)

Ratio i
减速比

Backlash
背隙

Output type
输出安装方式

伺服电机、交流电机、
步进电机、液压马达等

减速机外形尺寸图: 电机输入轴直径 ≤8 / Input ≤8

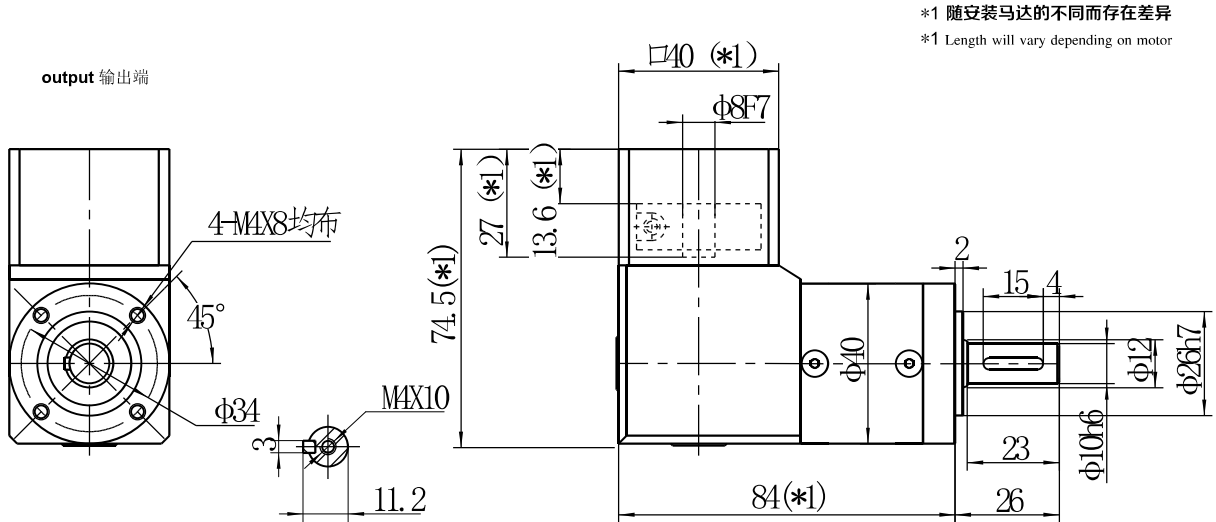

减速机性能参数 / Performance parameter

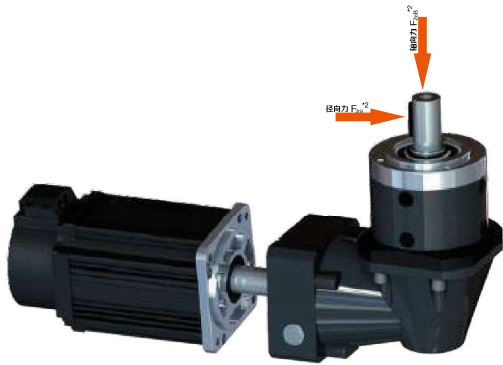

减速比 Ratio *1	i	3	4	5	6	8
额定输出扭矩 T _{2N} Nominal output torque	Nm	7.3	13.4	10	4.7	4.9
最大加速力矩 T _{2B} Maximum acceleration torque	Nm	23	20	16	7.9	7.4
急停扭矩 T _{2Not} Sudden stop torque	Nm	39	33.4	26.5	13.2	12.3
额定输入转速 Nominal input speed	rpm	3000				
最大输入转速 Maximum input speed	rpm	6000				
精密背隙 Precision backlash	P1-arcmin	≤12				
	P2-arcmin	≤18				
噪音 Noise	dB(A)	≤60				
容许最大径向负载 *2 Maximum radial load	N	220				
容许最大轴向负载 *2 Maximum axial load	N	200				
效率 Efficiency	%	≥95				
使用环境温度 Use of temperature	°C	<-15°C ~ +40°C>				
使用寿命 Service life	h	≥20000				
润滑 Lubrication *3		合成润滑油 (终身免保养)				
重量 (大概) Weight	kg	1kg				

减速机输出的几种方式 / Output mode

Output Shaft 实轴	S1	Shaft 光轴	S2	Shaft with key 单键轴
	S3	Spline shaft 花键轴	S-T	Special shaft 特殊轴
	According to customers 根据客户要求定制			
Output Shaft 孔轴	K1	Hollow 光内孔 (空心轴)	K2	Hollow with key 单键内孔
	K3	Spline hollow 花键内孔	K-T	Special hollow 特殊孔
	According to customers 根据客户要求定制			

*1. 减速比 i = N_{in}/N_{out} *2. 输出转速为 100rpm 时, 作用于输出轴中心位置 *3. 可定制高低温油脂

减速机订货选购说明 / Instructions for order and purchase of planetary reducer

WPL 040 L2-25-P2-S2



motor size

MODEL
系列代号

SIZE
规格

STAGE
段数 (级数)

Ratio i
减速比

Backlash
背隙

Output type
输出安装方式

伺服电机、交流电机、
步进电机、液压马达等

减速机外形尺寸图: 电机输入轴直径 ≤8 / Input ≤8

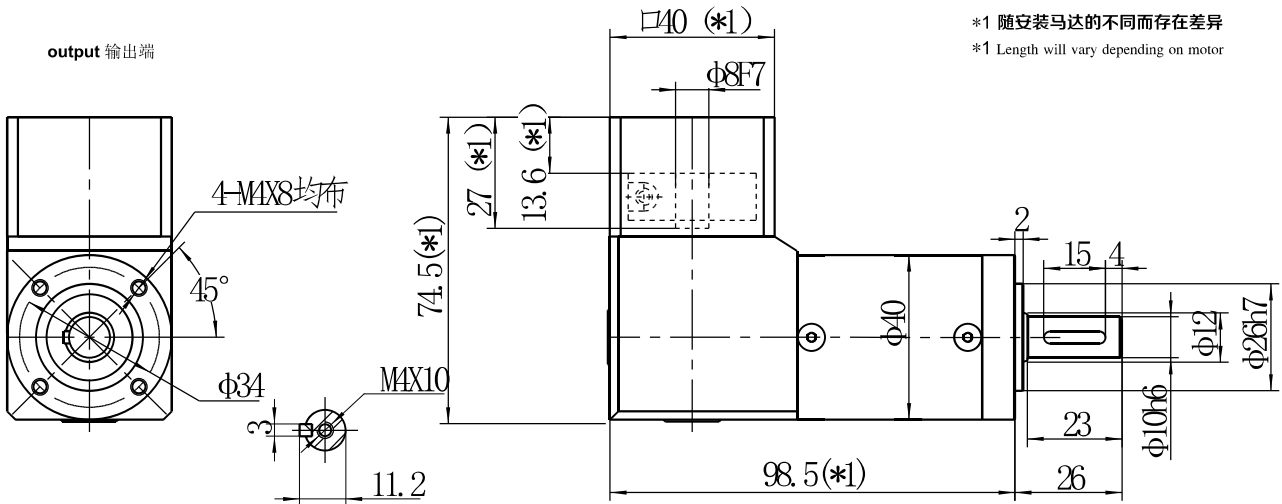

减速机性能参数 / Performance parameter

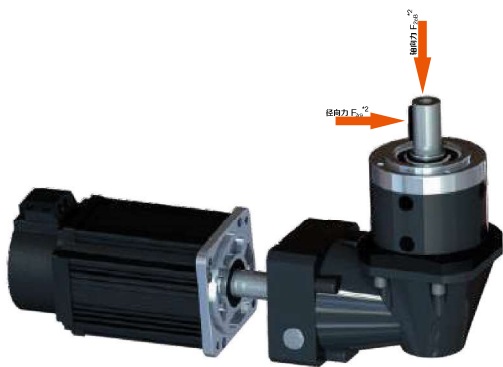

减速比 Ratio *1	i 推荐	9	12	16	15	25	/
	i 不推荐	20	32	40	50	64	
额定输出扭矩 T2N Nominal output torque	Nm	7.3	13.4	10	4.9		
最大加速力矩 T2B Maximum acceleration torque	Nm	23	20	16	7.4		
急停扭矩 T2Not Sudden stop torque	Nm	39	33.4	26.5	12.3		
额定输入转速 Nominal input speed	rpm	3000					
最大输入转速 Maximum input speed	rpm	6000					
精密背隙 Precision backlash	P1-arcmin	≤14					
	P2-arcmin	≤20					
噪音 Noise	dB(A)	≤60					
容许最大径向负载 *2 Maximum radial load	N	220					
容许最大轴向负载 *2 Maximum axial load	N	200					
效率 Efficiency	%	≥92					
使用环境温度 Use of temperature	°C	<-15°C~+40°C>					
使用寿命 Service life	h	≥20000					
润滑 Lubrication *3		合成润滑脂 (终身免保养)					
重量 (大概) Weight	kg	1.3kg					

减速机输出的几种方式 / Output mode

Output Shaft 实轴	S1	Shaft 光轴	S2	Shaft with key 单键轴
	S3	Spline shaft 花键轴	S-T	Special shaft 特殊轴
			According to customers 根据客户要求定制	
Output Shaft 孔轴	K1	Hollow 光内孔 (空心轴)	K2	Hollow with key 单键内孔
	K3	Spline hollow 花键内孔	K-T	Special hollow 特殊孔
			According to customers 根据客户要求定制	

*1. 减速比 $i = N_{in} / N_{out}$ *2. 输出转速为100rpm时, 作用于输出轴中心位置 *3. 可定制高低温油脂

减速机订货选购说明 / Instructions for order and purchase of planetary reducer

WPL 060 L1 - 5 - P2 - S2



motor size

MODEL
系列代号

SIZE
规格

STAGE
段数 (级数)

Ratio i
减速比

Backlash
背隙

Output type
输出安装方式

伺服电机、交流电机、
步进电机、液压马达等

减速机外形尺寸图: 电机输入轴直径 ≤ 8 / Input ≤ 8

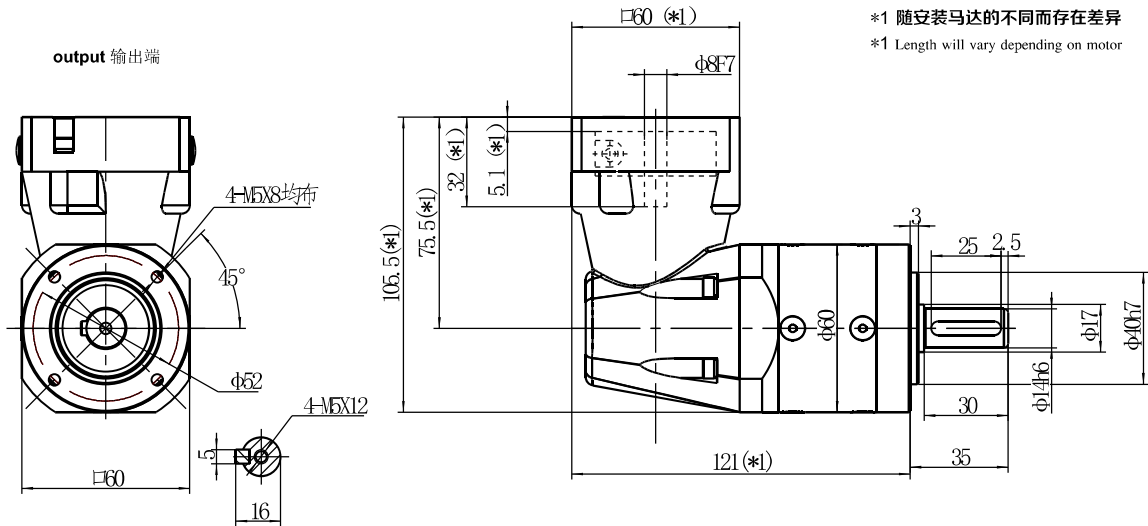

减速机性能参数 / Performance parameter

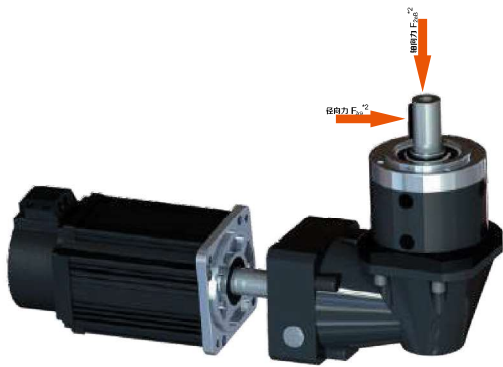

减速比 Ratio *1	i	3	4	5	6	8	10
额定输出扭矩 T2N Nominal output torque	Nm	18.6	34.5	24	20	18.5	14
最大加速力矩 T2B Maximum acceleration torque	Nm	57.5	82	64	39	38.5	25.5
急停扭矩 T2Not Sudden stop torque	Nm	96	137	107	65	64	42.8
额定输入转速 Nominal input speed	rpm	3000					
最大输入转速 Maximum input speed	rpm	6000					
精密背隙 Precision backlash	P1-arcmin	≤10					
	P2-arcmin	≤12					
噪音 Noise	dB(A)	≤63					
容许最大径向负载 *2 Maximum radial load	N	480					
容许最大轴向负载 *2 Maximum axial load	N	600					
效率 Efficiency	%	≥95					
使用环境温度 Use of temperature	°C	<-15°C ~ +40°C					
使用寿命 Service life	h	≥20000					
润滑 Lubrication *3		合成润滑脂 (终身免保养)					
重量 (大概) Weight	kg	2kg					

减速机输出的几种方式 / Output mode

Output Shaft 实轴	S1	Shaft 光轴	S2	Shaft with key 单键轴
	S3	Spline shaft 花键轴	S-T	Special shaft 特殊轴
	According to customers 根据客户要求定制			
Output Shaft 孔轴	K1	Hollow 光内孔 空心轴	K2	Hollow with key 带键内孔
	K3	Spline hollow 花键内孔	K-T	Special hollow 特殊孔
	According to customers 根据客户要求定制			

*1. 减速比 $i = N_{in} / N_{out}$ *2. 输出转速为100rpm时, 作用于输出轴中心位置 *3. 可定制高低温油脂

减速机订货选购说明 / Instructions for order and purchase of planetary reducer

WPL 060 L1 - 5 - P2 - S2



motor size

MODEL
系列代号

SIZE
规格

STAGE
段数 (级数)

Ratio i
减速比

Backlash
背隙

Output type
输出安装方式

伺服电机、交流电机、
步进电机、液压马达等

减速机外形尺寸图: 电机输入轴直径 ≤ 14 / Input ≤ 14

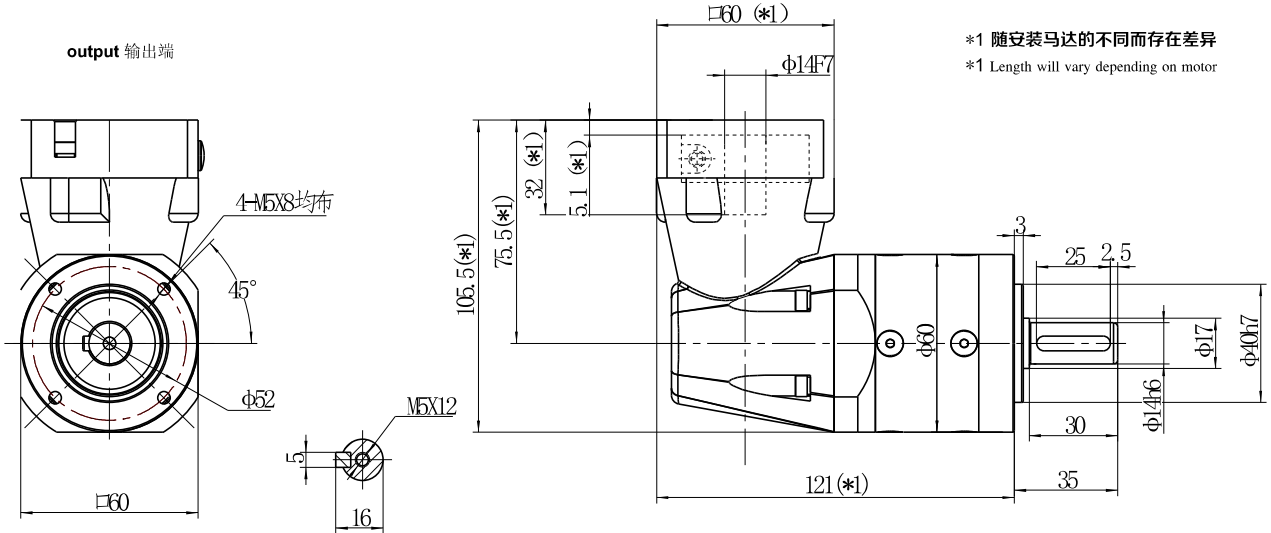

减速机性能参数 / Performance parameter

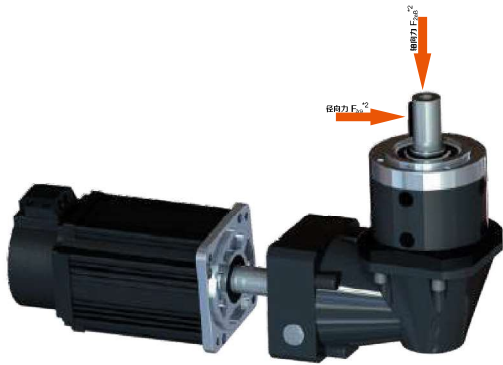

减速比 Ratio *1	i	3	4	5	6	8	10
额定输出扭矩 T2N Nominal output torque	Nm	18.6	34.5	24	20	18.5	14
最大加速力矩 T2B Maximum acceleration torque	Nm	57.5	82	64	39	38.5	25.5
急停扭矩 T2Not Sudden stop torque	Nm	96	137	107	65	64	42.8
额定输入转速 Nominal input speed	rpm	3000					
最大输入转速 Maximum input speed	rpm	6000					
精密背隙 Precision backlash	P1-arcmin	≤10					
	P2-arcmin	≤12					
噪音 Noise	dB(A)	≤63					
容许最大径向负载 *2 Maximum radial load	N	480					
容许最大轴向负载 *2 Maximum axial load	N	600					
效率 Efficiency	%	≥95					
使用环境温度 Use of temperature	°C	<-15°C ~ +40°C					
使用寿命 Service life	h	≥20000					
润滑 Lubrication *3		合成润滑脂 (终身免保养)					
重量 (大概) Weight	kg	2kg					

*1. 减速比 $i = N_{in} / N_{out}$ *2. 输出转速为100rpm时, 作用于输出轴中心位置 *3. 可定制高低温油脂

减速机输出的几种方式 / Output mode

Output Shaft 实轴	S1	Shaft 光轴	S2	Shaft with key 单键轴
	S3	Spline shaft 花键轴	S-T	Special shaft 特殊轴
Output Shaft 孔轴	K1	Hollow 光内孔 (inner hole)	K2	Hollow with key 单键内孔
	K3	Spline hollow 花键内孔	K-T	Special hollow 特殊孔
	According to customers 根据客户要求定制			

减速机订货选购说明 / Instructions for order and purchase of planetary reducer

WPL 060 L2-25-P2-S2



motor size

MODEL
系列代号

SIZE
规格

STAGE
段数 (级数)

Ratio i
减速比

Backlash
背隙

Output type
输出安装方式

伺服电机、交流电机、
步进电机、液压马达等

减速机外形尺寸图: 电机输入轴直径 ≤ 8 / Input ≤ 8

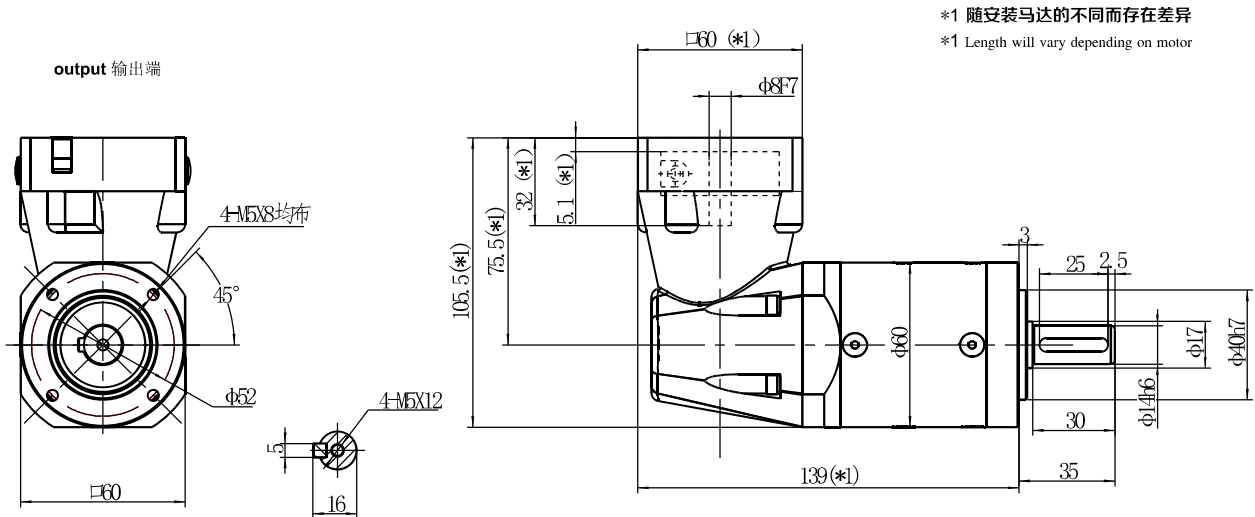

减速机性能参数 / Performance parameter

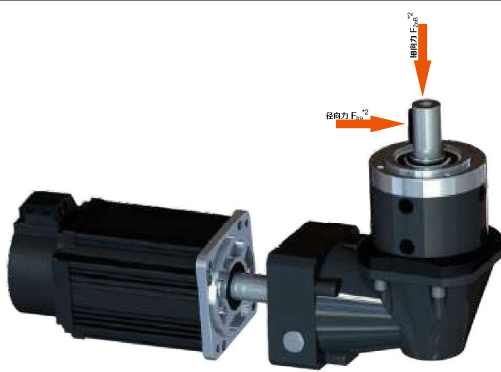

减速比 Ratio *1	i 推荐	9	12	16	15	25	/
	i 不推荐		20	32	40	50	
额定输出扭矩 T2N Nominal output torque	Nm	18.6	34.5	24	18.5		
最大加速力矩 T2B Maximum acceleration torque	Nm	57.5	82	64	38.5		
急停扭矩 T2Not Sudden stop torque	Nm	96	137	107	64		
额定输入转速 Nominal input speed	rpm	3000					
最大输入转速 Maximum input speed	rpm	6000					
精密背隙 Precision backlash	P1 -arcmin	≤12					
	P2 -arcmin	≤14					
噪音 Noise	dB(A)	≤63					
容许最大径向负载 *2 Maximum radial load	N	480					
容许最大轴向负载 *2 Maximum axial load	N	600					
效率 Efficiency	%	≥92					
使用环境温度 Use of temperature	°C	<-15°C ~ +40°C>					
使用寿命 Service life	h	≥20000					
润滑 Lubrication *3		合成润滑脂 (终身免保养)					
重量 (大概) Weight	kg	2.7kg					

减速机输出的几种方式 / Output mode

Output Shaft 实轴	S1	Shaft 光轴	S2	Shaft with key 单键轴
	S3	Spline shaft 花键轴	S-T	Special shaft 特殊轴
			According to customers 根据客户要求定制	
Output Shaft 孔轴	K1	Hollow 光内孔 (空心轴)	K2	Hollow with key 单键内孔
	K3	Spline hollow 花键内孔	K-T	Special hollow 特殊孔
			According to customers 根据客户要求定制	

*1. 减速比 i = N_{in} / N_{out} *2. 输出转速为 100rpm 时, 作用于输出轴中心位置 *3. 可定制高低温油脂

减速机订货选购说明 / Instructions for order and purchase of planetary reducer

WPL 060 L2-25-P2-S2



motor size

MODEL
系列代号

SIZE
规格

STAGE
段数 (级数)

Ratio i
减速比

Backlash
背隙

Output type
输出安装方式

伺服电机、交流电机、
步进电机、液压马达等

减速机外形尺寸图: 电机输入轴直径 ≤ 14 / Input ≤ 14

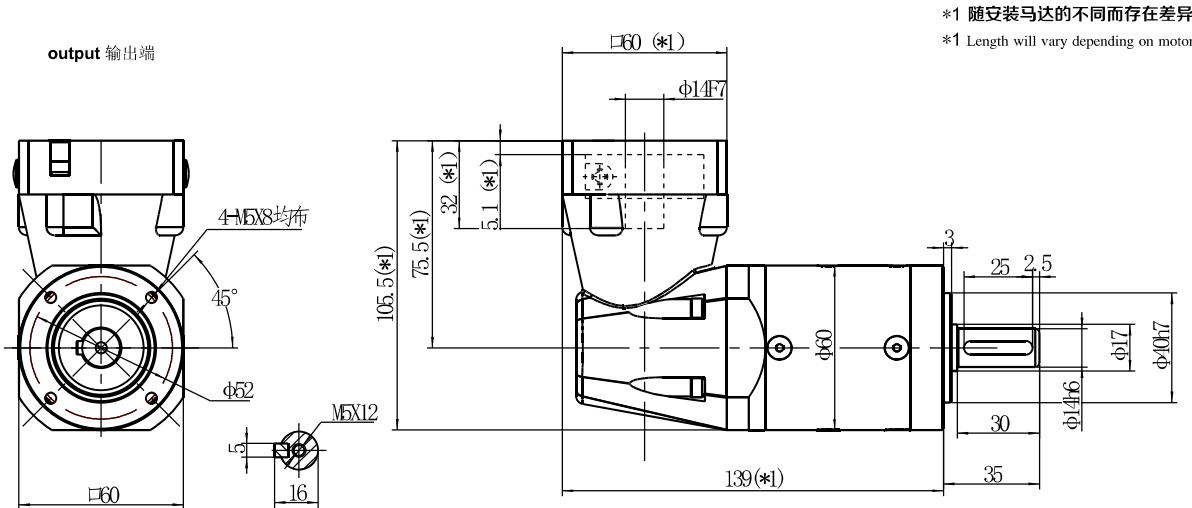

减速机性能参数 / Performance parameter

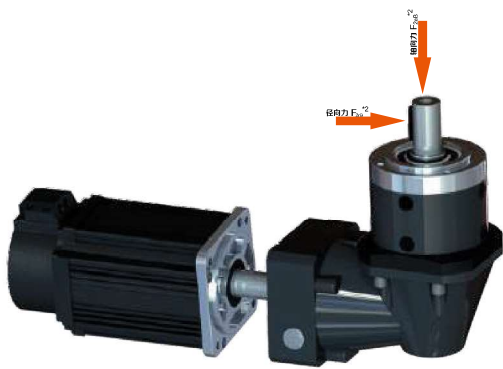

减速比 Ratio *1	i 推荐	9	12	16	15	25	64
	i 不推荐		20	32	40	50	80
额定输出扭矩 T2N Nominal output torque	Nm	18.6	34.5	24	18.5		
最大加速力矩 T2B Maximum acceleration torque	Nm	57.5	82	64	38.5		
急停扭矩 T2Not Sudden stop torque	Nm	96	137	107	64		
额定输入转速 Nominal input speed	rpm	3000					
最大输入转速 Maximum input speed	rpm	6000					
精密背隙 Precision backlash	P1-arcmin	≤12					
	P2-arcmin	≤14					
噪音 Noise	dB(A)	≤63					
容许最大径向负载 *2 Maximum radial load	N	480					
容许最大轴向负载 *2 Maximum axial load	N	600					
效率 Efficiency	%	≥92					
使用环境温度 Use of temperature	°C	<-15°C~+40°C>					
使用寿命 Service life	h	≥20000					
润滑 Lubrication *3		合成润滑脂 (终身免保养)					
重量 (大概) Weight	kg	2.7kg					

减速机输出的几种方式 / Output mode

Output Shaft 实轴	S1	Shaft 光轴	S2	Shaft with key 单键轴
	S3	Spline shaft 花键轴	S-T	Special shaft 特殊轴
			According to customers 根据客户要求定制	
Output Shaft 孔轴	K1	Hollow 光内孔 (空心轴)	K2	Hollow with key 带键内孔
	K3	Spline hollow 花键内孔	K-T	Special hollow 特殊孔
			According to customers 根据客户要求定制	

*1. 减速比 $i = N_{in} / N_{out}$ *2. 输出转速为100rpm时, 作用于输出轴中心位置 *3. 可定制高低温油脂

减速机订货选购说明 / Instructions for order and purchase of planetary reducer

WPL 080 L1 - 5 - P2 - S2



motor size

MODEL
系列代号

SIZE
规格

STAGE
段数 (级数)

Ratio i
减速比

Backlash
背隙

Output type
输出安装方式

伺服电机、交流电机、
步进电机、液压马达等

减速机外形尺寸图: 电机输入轴直径 ≤ 14 / Input ≤ 14

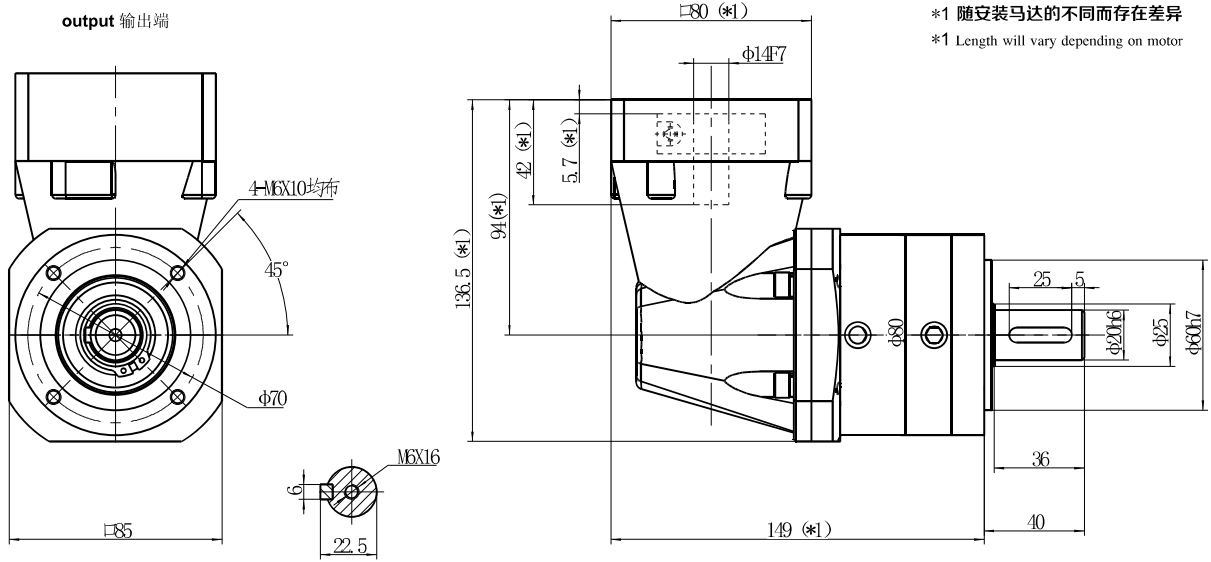

*1 随安装马达的不同而存在差异
*1 Length will vary depending on motor

减速机性能参数 / Performance parameter

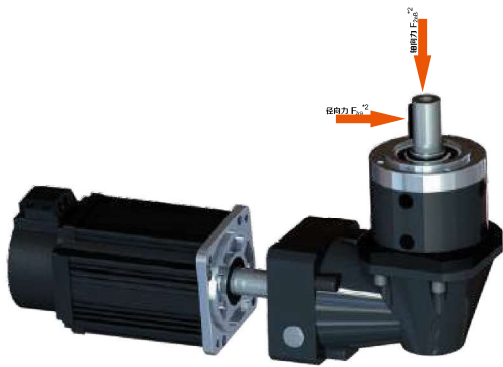

减速比 Ratio *1	i	3	4	5	6	8	10
额定输出扭矩 T2N Nominal output torque	Nm	38	73	64	55	59.5	41
最大加速力矩 T2B Maximum acceleration torque	Nm	120	200	136	84.5	93.5	61
急停扭矩 T2Not Sudden stop torque	Nm	200	333	226	141	156	102
额定输入转速 Nominal input speed	rpm	3000					
最大输入转速 Maximum input speed	rpm	6000					
精密背隙 Precision backlash	P1-arcmin	≤10					
	P2-arcmin	≤12					
噪音 Noise	dB(A)	≤65					
容许最大径向负载 *2 Maximum radial load	N	900					
容许最大轴向负载 *2 Maximum axial load	N	1200					
效率 Efficiency	%	≥95					
使用环境温度 Use of temperature	°C	<-15°C ~ +40°C					
使用寿命 Service life	h	≥20000					
润滑 Lubrication *3		合成润滑脂 (终身免保养)					
重量 (大概) Weight	kg	6.5kg					

*1. 减速比 $i = N_{in} / N_{out}$ *2. 输出转速为100rpm时, 作用于输出轴中心位置 *3. 可定制高低温油脂

减速机输出的几种方式 / Output mode

Output Shaft 实轴	S1	Shaft 光轴	S2	Shaft with key 单键轴
	S3	Spline shaft 花键轴	S-T	Special shaft 特殊轴
Output Shaft 孔轴	K1	Hollow 光内孔 空心轴	K2	Hollow with key 带键内孔
	K3	Spline hollow 花键内孔	K-T	Special hollow 特殊孔
	According to customers 根据客户要求定制			

减速机订货选购说明 / Instructions for order and purchase of planetary reducer

WPL 080 L1 - 5 - P2 - S2



motor size

MODEL
系列代号

SIZE
规格

STAGE
段数 (级数)

Ratio i
减速比

Backlash
背隙

Output type
输出安装方式

伺服电机、交流电机、
步进电机、液压马达等

减速机外形尺寸图: 电机输入轴直径 ≤ 19 / Input ≤ 19

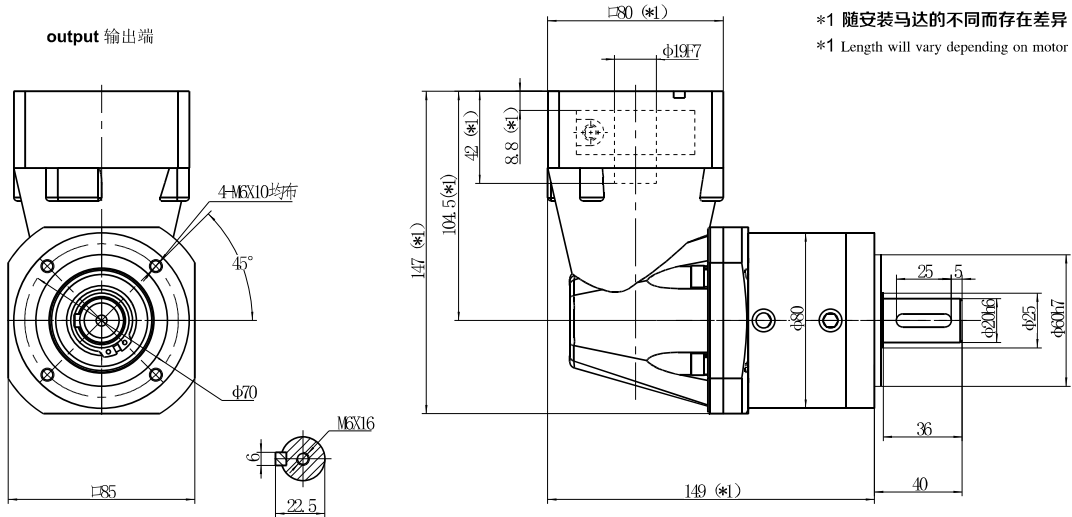

减速机性能参数 / Performance parameter

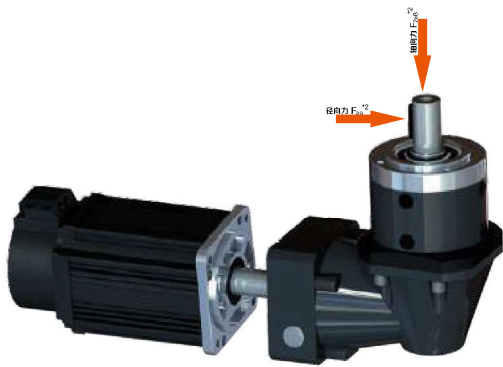

减速比 Ratio *1	i	3	4	5	6	8	10
额定输出扭矩 T2N Nominal output torque	Nm	38	73	64	55	59.5	41
最大加速力矩 T2B Maximum acceleration torque	Nm	120	200	136	84.5	93.5	61
急停扭矩 T2Not Sudden stop torque	Nm	200	333	226	141	156	102
额定输入转速 Nominal input speed	rpm	3000					
最大输入转速 Maximum input speed	rpm	6000					
精密背隙 Precision backlash	P1 - arcmin	≤ 10					
	P2 - arcmin	≤ 12					
噪音 Noise	dB(A)	≤ 65					
容许最大径向负载 *2 Maximum radial load	N	900					
容许最大轴向负载 *2 Maximum axial load	N	1200					
效率 Efficiency	%	≥ 95					
使用环境温度 Use of temperature	°C	< -15°C ~ +40°C					
使用寿命 Service life	h	≥ 20000					
润滑 Lubrication *3		合成润滑脂 (终身免保养)					
重量 (大概) Weight	kg	6.5kg					

*1. 减速比 $i = N_{in} / N_{out}$ *2. 输出转速为 100rpm 时, 作用于输出轴中心位置 *3. 可定制高低温油脂

减速机输出的几种方式 / Output mode

Output Shaft 实轴	S1	Shaft 光轴	S2	Shaft with key 单键轴
	S3	Spline shaft 花键轴	S-T	Special shaft 特殊轴
Output Shaft 孔轴	K1	Hollow 光内孔 (普通)	K2	Hollow with key 单键内孔
	K3	Spline hollow 花键内孔	K-T	Special hollow 特殊孔
	According to customers 根据客户要求定制			

减速机订货选购说明 / Instructions for order and purchase of planetary reducer

WPL 080 L2-25-P2-S2



motor size

MODEL
系列代号

SIZE
规格

STAGE
段数 (级数)

Ratio i
减速比

Backlash
背隙

Output type
输出安装方式

伺服电机、交流电机、
步进电机、液压马达等

减速机外形尺寸图: 电机输入轴直径 ≤ 14 / Input ≤ 14

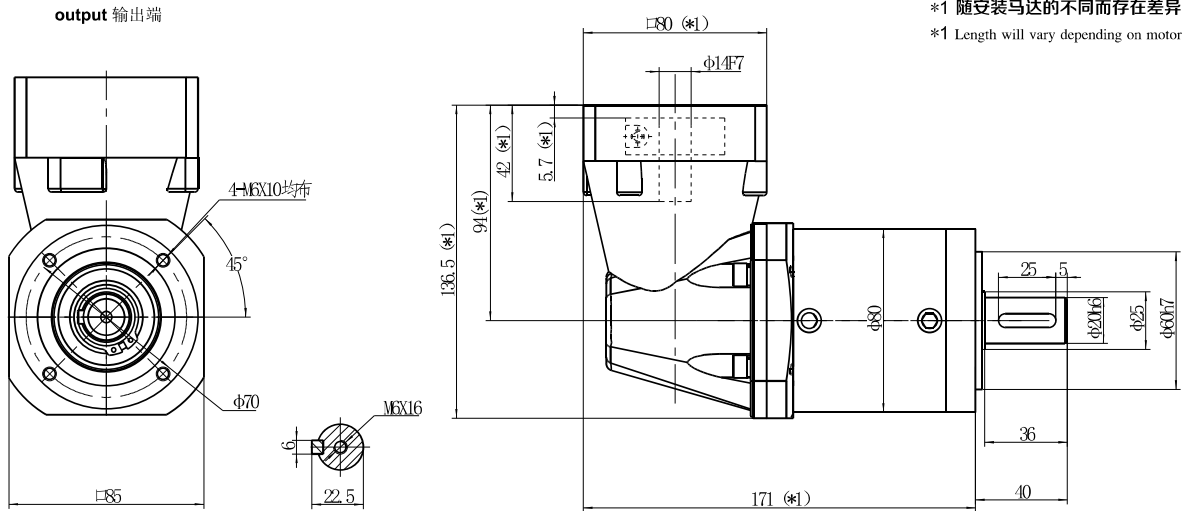

减速机性能参数 / Performance parameter

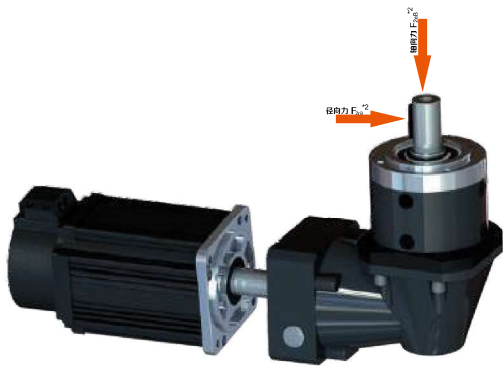

减速比 Ratio *1	i 推荐	9	12	16	15	25	/
	i 不推荐	20	32	40	50	64	
额定输出扭矩 T2N Nominal output torque	Nm	38	73	64	59.5		
最大加速力矩 T2B Maximum acceleration torque	Nm	120	200	135.5	93.5		
急停扭矩 T2Not Sudden stop torque	Nm	200	333	226	156		
额定输入转速 Nominal input speed	rpm	3000					
最大输入转速 Maximum input speed	rpm	6000					
精密背隙 Precision backlash	P1-arcmin	≤12					
	P2-arcmin	≤14					
噪音 Noise	dB(A)	≤65					
容许最大径向负载 *2 Maximum radial load	N	900					
容许最大轴向负载 *2 Maximum axial load	N	1200					
效率 Efficiency	%	≥92					
使用环境温度 Use of temperature	°C	<-15°C~+40°C>					
使用寿命 Service life	h	≥20000					
润滑 Lubrication *3		合成润滑脂 (终身免保养)					
重量 (大概) Weight	kg	7.7kg					

减速机输出的几种方式 / Output mode

Output Shaft 实轴	S1	Shaft 光轴	S2	Shaft with key 单键轴
	S3	Spline shaft 花键轴	S-T	Special shaft 特殊轴
		According to customers 根据客户要求定制		
Output Shaft 孔轴	K1	Hollow 光内孔 (空心轴)	K2	Hollow with key 带键内孔
	K3	Spline hollow 花键内孔	K-T	Special hollow 特殊孔
		According to customers 根据客户要求定制		

*1. 减速比 $i = N_{in} / N_{out}$ *2. 输出转速为100rpm时, 作用于输出轴中心位置 *3. 可定制高低温油脂

减速机订货选购说明 / Instructions for order and purchase of planetary reducer

WPL 080 L2-25-P2-S2



motor size

MODEL
系列代号

SIZE
规格

STAGE
段数(级数)

Ratio i
减速比

Backlash
背隙

Output type
输出安装方式

伺服电机、交流电机、
步进电机、液压马达等

减速机外形尺寸图: 电机输入轴直径 ≤ 19 / Input ≤ 19

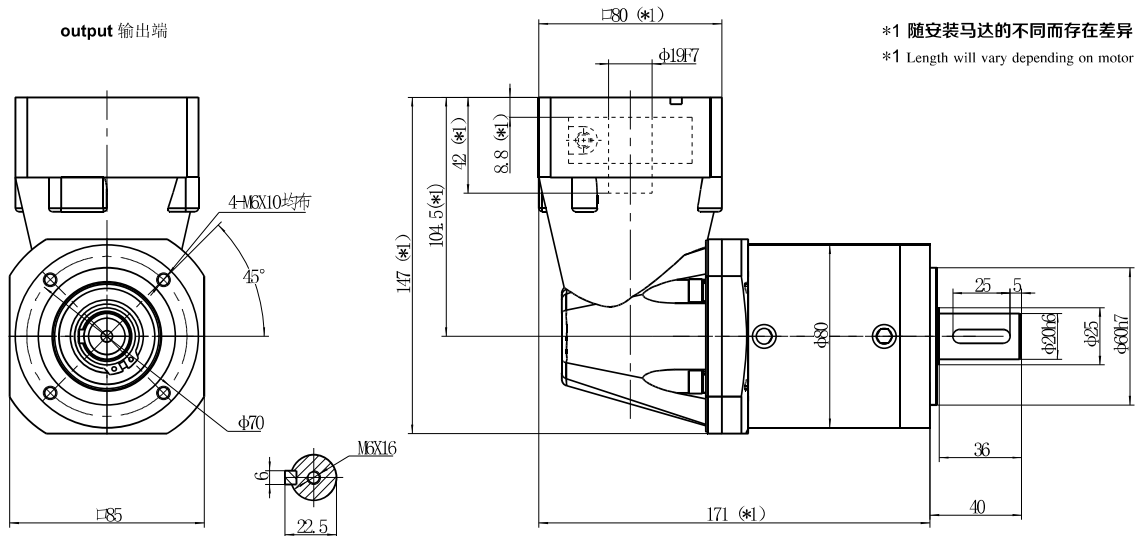

减速机性能参数 / Performance parameter

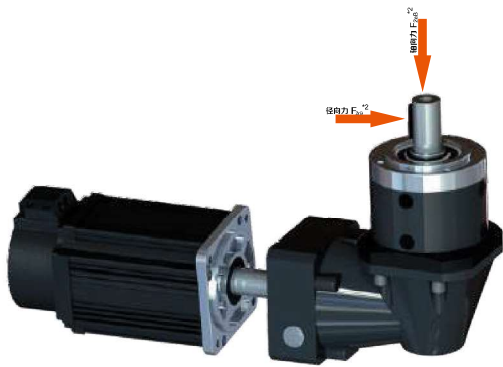

减速比 Ratio *1	i 推荐 i 不推荐	9	12	16	15	25	64
			20	32	40	50	80
额定输出扭矩 T2N Nominal output torque	Nm	38	73	64	59.5		
最大加速力矩 T2B Maximum acceleration torque	Nm	120	200	135.5	93.5		
急停扭矩 T2Not Sudden stop torque	Nm	200	333	226	156		
额定输入转速 Nominal input speed	rpm	3000					
最大输入转速 Maximum input speed	rpm	6000					
精密背隙 Precision backlash	P1-arcmin	≤12					
	P2-arcmin	≤14					
噪音 Noise	dB(A)	≤65					
容许最大径向负载 *2 Maximum radial load	N	900					
容许最大轴向负载 *2 Maximum axial load	N	1200					
效率 Efficiency	%	≥92					
使用环境温度 Use of temperature	°C	<-15°C~+40°C>					
使用寿命 Service life	h	≥20000					
润滑 Lubrication *3		合成润滑脂 (终身免保养)					
重量(大概) Weight	kg	7.7kg					

减速机输出的几种方式 / Output mode

Output Shaft 实轴	S1	Shaft 光轴	S2	Shaft with key 单键轴
	S3	Spline shaft 花键轴	S-T	Special shaft 特殊轴
			According to customers 根据客户要求定制	
Output Shaft 孔轴	K1	Hollow 光内孔 (空心轴)	K2	Hollow with key 带键内孔
	K3	Spline hollow 花键内孔	K-T	Special hollow 特殊孔
			According to customers 根据客户要求定制	

*1. 减速比 $i = N_{in} / N_{out}$ *2. 输出转速为100rpm时, 作用于输出轴中心位置 *3. 可定制高低温油脂

AB
ABR
AD
ADR
AE
AER
AF
AFR
PN
WPN
IB
IBR
PW
PL
WPL
PF
WPF
PS
WPS
NTX

减速机订货选购说明 / Instructions for order and purchase of planetary reducer

WPL 120 L1 - 5 - P2 - S2



motor size

MODEL
系列代号

SIZE
规格

STAGE
段数 (级数)

Ratio i
减速比

Backlash
背隙

Output type
输出安装方式

伺服电机、交流电机、
步进电机、液压马达等

减速机外形尺寸图: 电机输入轴直径 ≤ 19 / Input ≤ 19

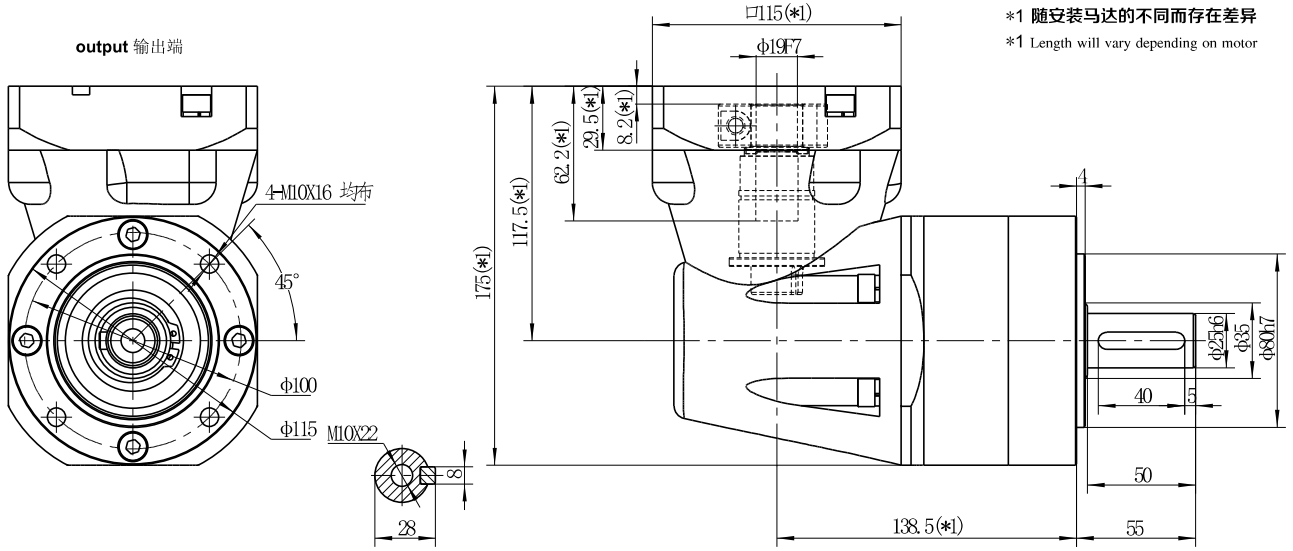

减速机性能参数 / Performance parameter

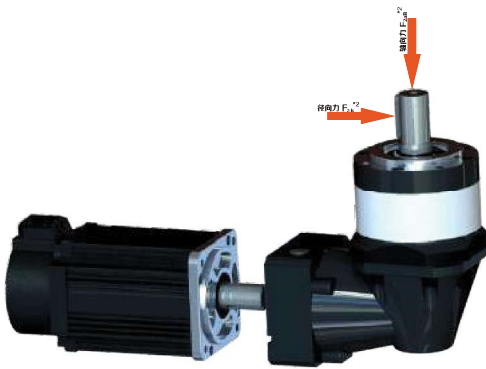

减速比 Ratio *1	i	3	4	5	6	8	10
额定输出扭矩 T2N Nominal output torque	Nm	109	208	178	128	116	65
最大加速力矩 T2B Maximum acceleration torque	Nm	306	471	296	173	182	105
急停扭矩 T2Not Sudden stop torque	Nm	510	785	494	289	304	175
额定输入转速 Nominal input speed	rpm	3000					
最大输入转速 Maximum input speed	rpm	6000					
精密背隙 Precision backlash	P1-arcmin	≤10					
	P2-arcmin	≤12					
噪音 Noise	dB(A)	≤68					
容许最大径向负载 *2 Maximum radial load	N	1850					
容许最大轴向负载 *2 Maximum axial load	N	2800					
效率 Efficiency	%	≥95					
使用环境温度 Use of temperature	°C	<-15°C ~ +40°C>					
使用寿命 Service life	h	≥20000					
润滑 Lubrication *3		合成润滑脂 (终身免保养)					
重量 (大概) Weight	kg	10.5kg					

减速机输出的几种方式 / Output mode

Output Shaft 实轴	S1	Shaft 光轴	S2	Shaft with key 单键轴
	S3	Spline shaft 花键轴	S-T	Special shaft 特殊轴
	According to customers 根据客户要求定制			
Output Shaft 孔轴	K1	Hollow 光内孔 (空心轴)	K2	Hollow with key 单键内孔
	K3	Spline hollow 花键内孔	K-T	Special hollow 特殊孔
	According to customers 根据客户要求定制			

*1. 减速比 i = N_{in} / N_{out} *2. 输出转速为 100rpm 时, 作用于输出轴中心位置 *3. 可定制高低温油脂

减速机订货选购说明 / Instructions for order and purchase of planetary reducer

WPL 120 L1 - 5 - P2 - S2



motor size

MODEL
系列代号

SIZE
规格

STAGE
段数 (级数)

Ratio i
减速比

Backlash
背隙

Output type
输出安装方式

伺服电机、交流电机、
步进电机、液压马达等

减速机外形尺寸图: 电机输入轴直径 ≤ 24 / Input ≤ 24

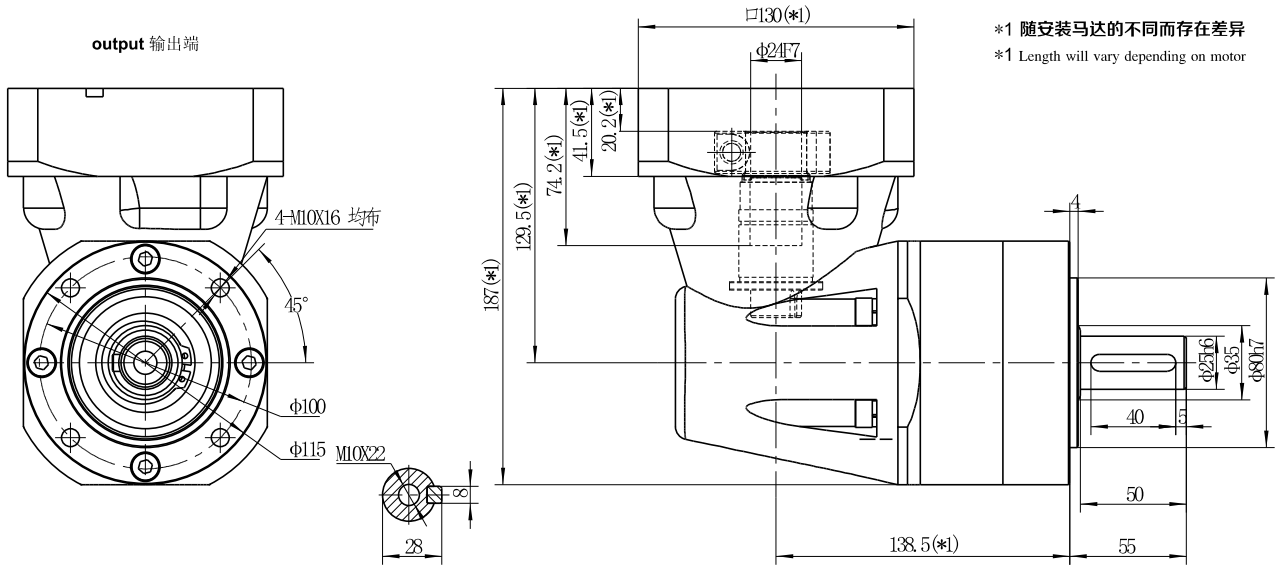

减速机性能参数 / Performance parameter

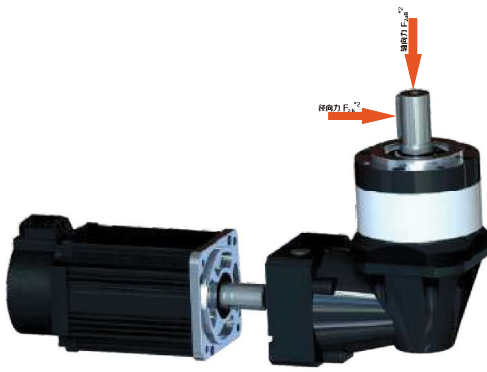

减速比 Ratio *1	i	3	4	5	6	8	10
额定输出扭矩 T2N Nominal output torque	Nm	109	208	178	128	116	65
最大加速力矩 T2B Maximum acceleration torque	Nm	306	471	296	173	182	105
急停扭矩 T2Not Sudden stop torque	Nm	510	785	494	289	304	175
额定输入转速 Nominal input speed	rpm	3000					
最大输入转速 Maximum input speed	rpm	6000					
精密背隙 Precision backlash	P1-arcmin	≤10					
	P2-arcmin	≤12					
噪音 Noise	dB(A)	≤68					
容许最大径向负载 *2 Maximum radial load	N	1850					
容许最大轴向负载 *2 Maximum axial load	N	2800					
效率 Efficiency	%	≥95					
使用环境温度 Use of temperature	°C	<-15°C ~ +40°C					
使用寿命 Service life	h	≥20000					
润滑 Lubrication *3		合成润滑脂 (终身免保养)					
重量 (大概) Weight	kg	10.5kg					

*1. 减速比 $i = N_{in} / N_{out}$ *2. 输出转速为100rpm时, 作用于输出轴中心位置 *3. 可定制高低温油脂

减速机输出的几种方式 / Output mode

Output Shaft 实轴	S1	Shaft 光轴	S2	Shaft with key 单键轴
	S3	Spline shaft 花键轴	S-T	Special shaft 特殊轴
	According to customers 根据客户要求定制			
Output Shaft 孔轴	K1	Hollow 光内孔 (空心轴)	K2	Hollow with key 单键内孔
	K3	Spline hollow 花键内孔	K-T	Special hollow 特殊孔
	According to customers 根据客户要求定制			

减速机订货选购说明 / Instructions for order and purchase of planetary reducer

WPL 120 L2-25-P2-S2



motor size

MODEL
系列代号

SIZE
规格

STAGE
段数 (级数)

Ratio i
减速比

Backlash
背隙

Output type
输出安装方式

伺服电机、交流电机、
步进电机、液压马达等

减速机外形尺寸图: 电机输入轴直径 ≤ 19 / Input ≤ 19

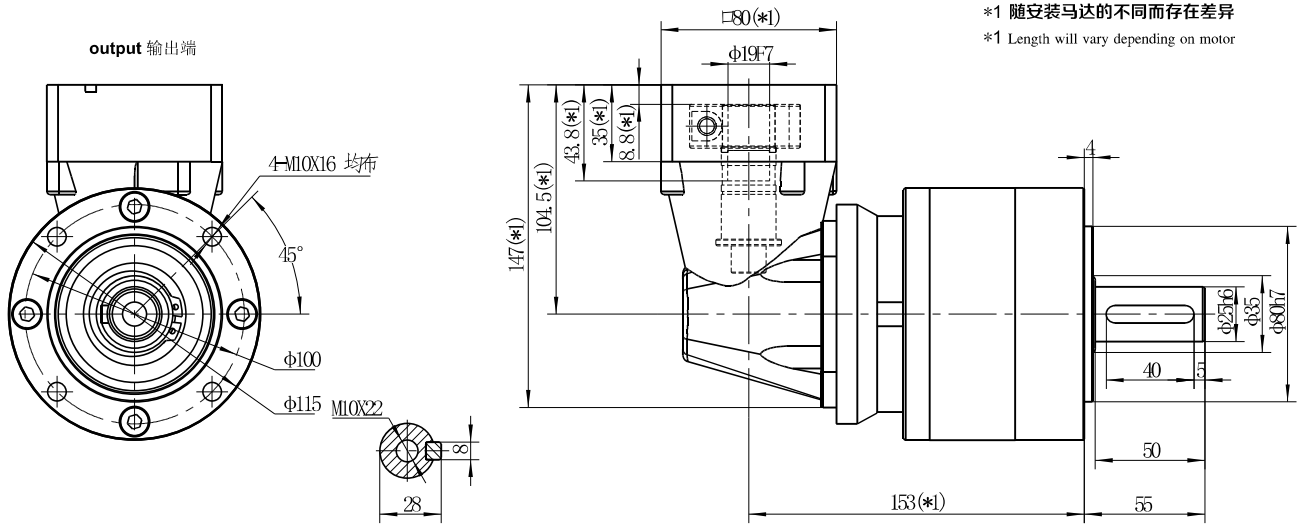

*1 随安装马达的不同而存在差异
*1 Length will vary depending on motor

减速机性能参数 / Performance parameter

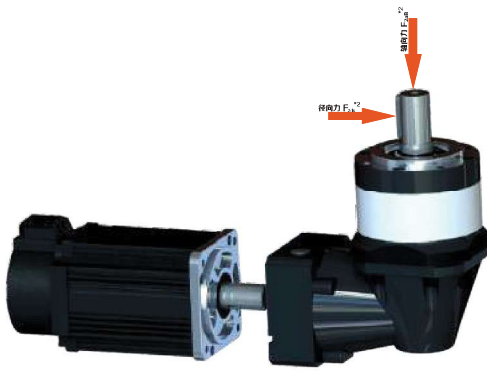

减速比 Ratio *1	i	3	4	5	6	8	10
额定输出扭矩 T2N Nominal output torque	Nm	109	208	178	128	116	65
最大加速力矩 T2B Maximum acceleration torque	Nm	306	471	296	173	182	105
急停扭矩 T2Not Sudden stop torque	Nm	510	785	494	289	304	175
额定输入转速 Nominal input speed	rpm	3000					
最大输入转速 Maximum input speed	rpm	6000					
精密背隙 Precision backlash	P1-arcmin	≤10					
	P2-arcmin	≤12					
噪音 Noise	dB(A)	≤68					
容许最大径向负载 *2 Maximum radial load	N	1850					
容许最大轴向负载 *2 Maximum axial load	N	2800					
效率 Efficiency	%	≥95					
使用环境温度 Use of temperature	°C	<-15°C ~ +40°C					
使用寿命 Service life	h	≥20000					
润滑 Lubrication *3		合成润滑脂 (终身免保养)					
重量 (大概) Weight	kg	10.5kg					

*1. 减速比 $i = N_{in} / N_{out}$ *2. 输出转速为100rpm时, 作用于输出轴中心位置 *3. 可定制高低温油脂

减速机输出的几种方式 / Output mode

Output Shaft 实轴	S1	Shaft 光轴	S2	Shaft with key 单键轴
	S3	Spline shaft 花键轴	S-T	Special shaft 特殊轴
			According to customers 根据客户要求定制	
Output Shaft 孔轴	K1	Hollow 光内孔 (空心轴)	K2	Hollow with key 单键内孔
	K3	Spline hollow 花键内孔	K-T	Special hollow 特殊孔
			According to customers 根据客户要求定制	

减速机订货选购说明 / Instructions for order and purchase of planetary reducer

WPL 120 L2-25-P2-S2



motor size

MODEL
系列代号

SIZE
规格

STAGE
段数 (级数)

Ratio i
减速比

Backlash
背隙

Output type
输出安装方式

伺服电机、交流电机、
步进电机、液压马达等

减速机外形尺寸图: 电机输入轴直径 ≤ 24 / Input ≤ 24

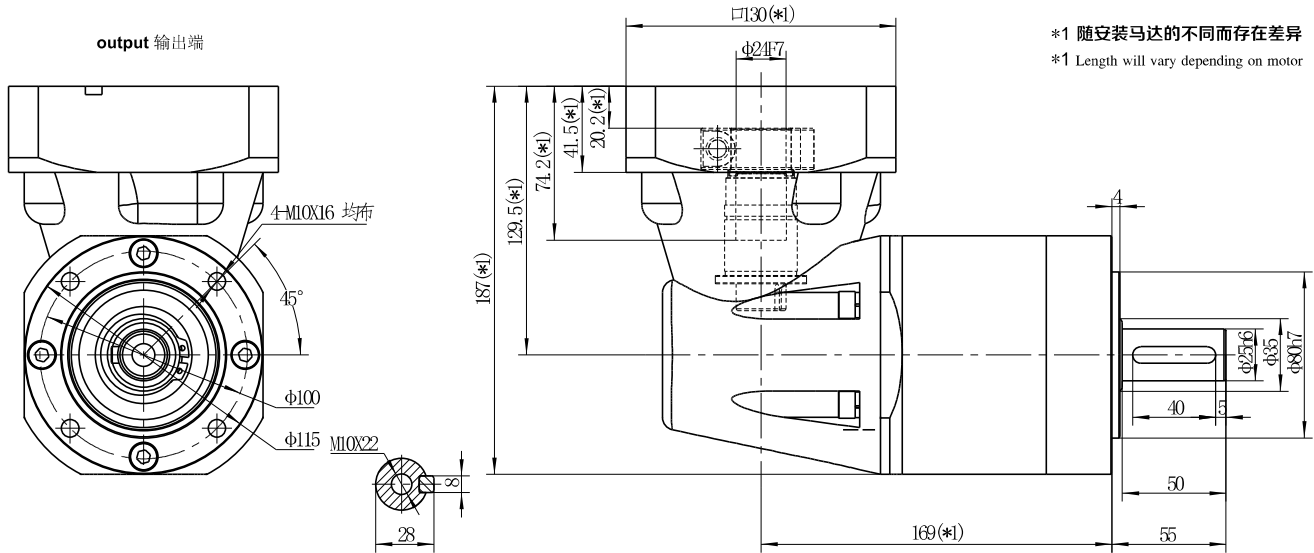

*1 随安装马达的不同而存在差异
*1 Length will vary depending on motor

减速机性能参数 / Performance parameter

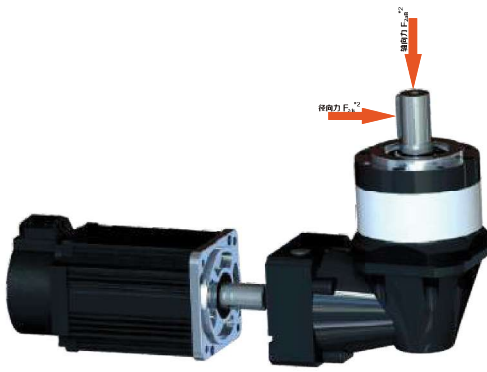

	减速比 Ratio *1	i 推荐					
		9	12	16	15	25	64
额定输出扭矩 T2N Nominal output torque	Nm	109	207.5	177.5	116	80	
最大加速力矩 T2B Maximum acceleration torque	Nm	306	471	296	182		
急停扭矩 T2Not Sudden stop torque	Nm	510	785	494	304		
额定输入转速 Nominal input speed	rpm	3000					
最大输入转速 Maximum input speed	rpm	6000					
精密背隙 Precision backlash	P1-arcmin	≤12					
	P2-arcmin	≤14					
噪音 Noise	dB(A)	≤68					
容许最大径向负载 Maximum radial load	N	1850					
容许最大轴向负载 *2 Maximum axial load	N	2800					
效率 Efficiency	%	≥92					
使用环境温度 Use of temperature	°C	<-15°C~+40°C>					
使用寿命 Service life	h	≥20000					
润滑 Lubrication *3		合成润滑脂 (终身免保养)					
重量 (大概) Weight	kg	13kg					

*1. 减速比 $i = N_{in} / N_{out}$ *2. 输出转速为100rpm时, 作用于输出轴中心位置 *3. 可定制高低温油脂

减速机输出的几种方式 / Output mode

Output Shaft 实轴	S1	Shaft 光轴	S2	Shaft with key 单键轴
	S3	Spline shaft 花键轴	S-T	Special shaft 特殊轴
			According to customers 根据客户要求定制	
Output Shaft 孔轴	K1	Hollow 光内孔 (空心轴)	K2	Hollow with key 单键内孔
	K3	Spline hollow 花键内孔	K-T	Special hollow 特殊孔
			According to customers 根据客户要求定制	

减速机订货选购说明 / Instructions for order and purchase of planetary reducer

WPL 140 L1 - 5 - P2 - S2



motor size

MODEL
系列代号

SIZE
规格

STAGE
段数 (级数)

Ratio i
减速比

Backlash
背隙

Output type
输出安装方式

伺服电机、交流电机、
步进电机、液压马达等

减速机外形尺寸图: 电机输入轴直径 ≤ 22 / Input ≤ 22

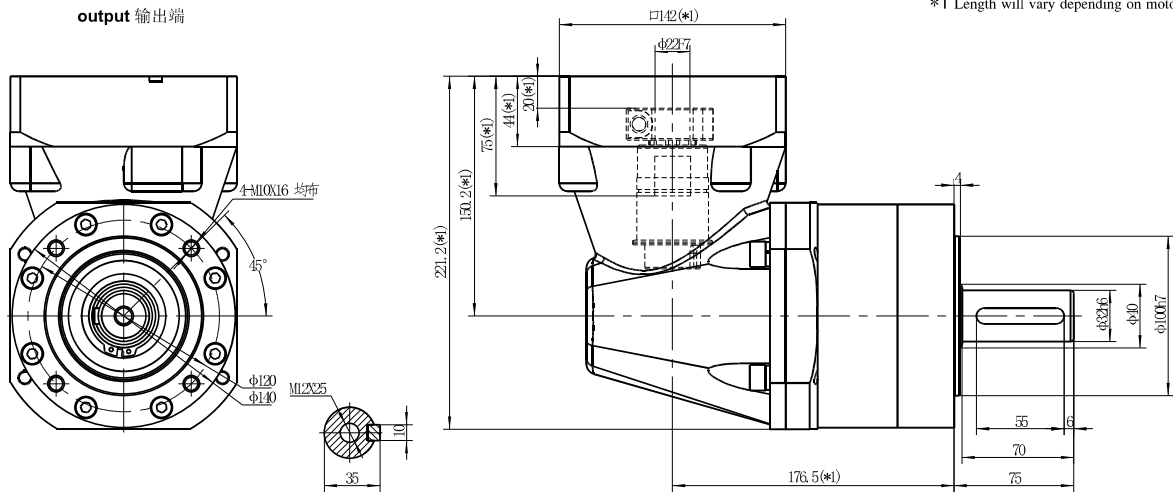

*1 随安装马达的不同而存在差异

*1 Length will vary depending on motor

减速机性能参数 / Performance parameter

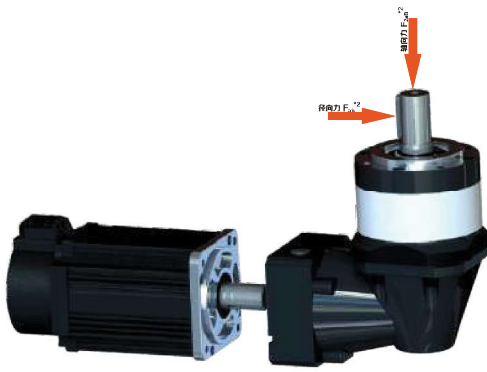

减速比 Ratio *1	i	3	4	5	6	8	10
额定输出扭矩 T2N Nominal output torque	Nm	231	452	415	324	216	120
最大加速力矩 T2B Maximum acceleration torque	Nm	669	922	577	392	347	194
急停扭矩 T2Not Sudden stop torque	Nm	1116	1537	962	653	579	323
额定输入转速 Nominal input speed	rpm	3000					
最大输入转速 Maximum input speed	rpm	6000					
精密背隙 Precision backlash	P1-arcmin	≤ 6					
	P2-arcmin	≤ 8					
噪音 Noise	dB(A)	≤ 68					
容许最大径向负载 *2 Maximum radial load	N	2000					
容许最大轴向负载 *2 Maximum axial load	N	3500					
效率 Efficiency	%	≥ 97					
使用环境温度 Use of temperature	°C	<-15°C ~ +40°C					
使用寿命 Service life	h	≥ 20000					
润滑 Lubrication *3		合成润滑脂 (终身免保养)					
重量 (大概) Weight	kg	6kg					

*1. 减速比 $i = N_{in} / N_{out}$ *2. 输出转速为 100rpm 时, 作用于输出轴中心位置 *3. 可定制高低温油脂

减速机输出的几种方式 / Output mode

Output Shaft 实轴	S1	Shaft 光轴	S2	Shaft with key 单键轴
	S3	Spline shaft 花键轴	S-T	Special shaft 特殊轴
Output Shaft 孔轴	K1	Hollow 光内孔 (center)	K2	Hollow with key 单键内孔
	K3	Spline hollow 花键内孔	K-T	Special hollow 特殊孔
				According to customers 根据客户要求定制

减速机订货选购说明 / Instructions for order and purchase of planetary reducer

WPL 140 L1 - 5 - P2 - S2



motor size

MODEL
系列代号

SIZE
规格

STAGE
段数 (级数)

Ratio i
减速比

Backlash
背隙

Output type
输出安装方式

伺服电机、交流电机、
步进电机、液压马达等

减速机外形尺寸图: 电机输入轴直径 ≤ 35 / Input ≤ 35

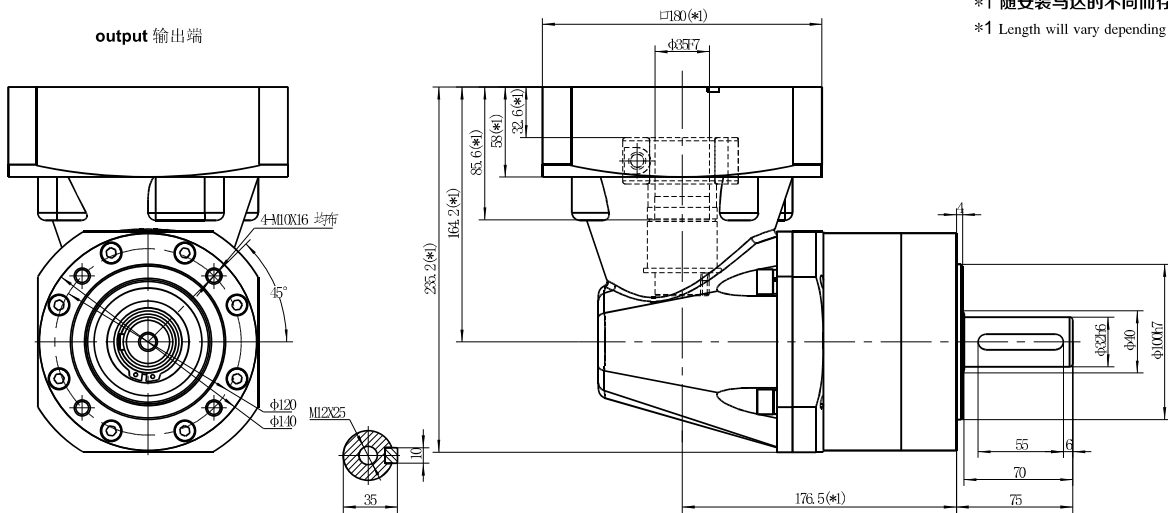

*1 随安装马达的不同而存在差异
*1 Length will vary depending on motor

减速机性能参数 / Performance parameter

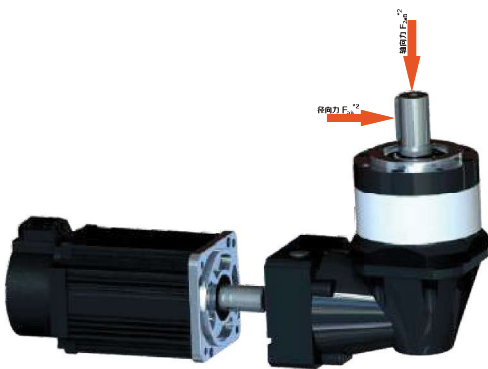

减速比 Ratio *1	i	3	4	5	6	8	10
额定输出扭矩 T2N Nominal output torque	Nm	231	452	415	324	216	120
最大加速力矩 T2B Maximum acceleration torque	Nm	669	922	577	392	347	194
急停扭矩 T2Not Sudden stop torque	Nm	1116	1537	962	653	579	323
额定输入转速 Nominal input speed	rpm	3000					
最大输入转速 Maximum input speed	rpm	6000					
精密背隙 Precision backlash	P1-arcmin	≤6					
	P2-arcmin	≤8					
噪音 Noise	dB(A)	≤68					
容许最大径向负载 *2 Maximum radial load	N	2000					
容许最大轴向负载 *2 Maximum axial load	N	3500					
效率 Efficiency	%	≥97					
使用环境温度 Use of temperature	°C	<-15°C ~ +40°C>					
使用寿命 Service life	h	≥20000					
润滑 Lubrication *3		合成润滑脂 (终身免保养)					
重量 (大概) Weight	kg	6kg					

*1. 减速比 $i = N_{in} / N_{out}$ *2. 输出转速为100rpm时, 作用于输出轴中心位置 *3. 可定制高低温油脂

减速机输出的几种方式 / Output mode

Output Shaft 实轴	S1	Shaft 光轴	S2	Shaft with key 单键轴
	S3	Spline shaft 花键轴	S-T	Special shaft 特殊轴
Output Shaft 孔轴	K1	Hollow 光内孔 (concentric)	K2	Hollow with key 单键内孔
	K3	Spline hollow 花键内孔	K-T	Special hollow 特殊孔
			According to customers 根据客户要求定制	

减速机订货选购说明 / Instructions for order and purchase of planetary reducer

WPL 140 L2 - 25 - P2 - S2



motor size

MODEL
系列代号

SIZE
规格

STAGE
段数 (级数)

Ratio i
减速比

Backlash
背隙

Output type
输出安装方式

伺服电机、交流电机、
步进电机、液压马达等

减速机外形尺寸图: 电机输入轴直径≤22/ Input ≤22

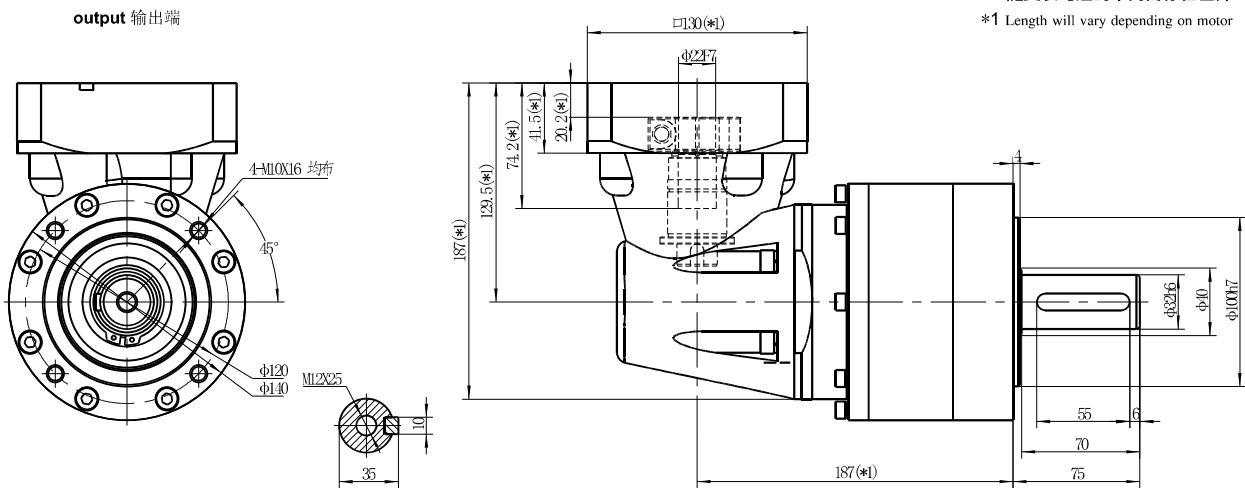

减速机性能参数 / Performance parameter

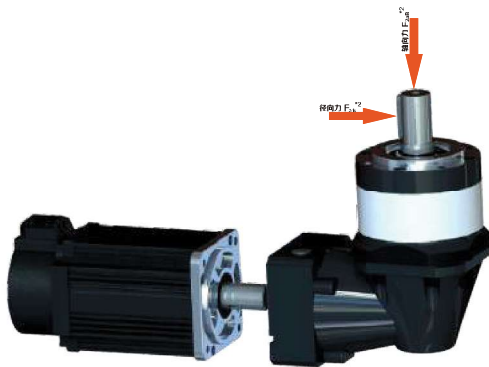

减速机性能参数	减速比 Ratio *1	i 推荐					
		9	12	16	15	25	64
额定输出扭矩 T2N Nominal output torque	Nm	231	452	415	216		
最大加速力矩 T2B Maximum acceleration torque	Nm	669	922	577	347		
急停扭矩 T2Not Sudden stop torque	Nm	1116	1537	962	579		
额定输入转速 Nominal input speed	rpm	3000					
最大输入转速 Maximum input speed	rpm	6000					
精密背隙 Precision backlash	P1-arcmin	≤8					
	P2-arcmin	≤10					
噪音 Noise	dB(A)	≤68					
容许最大径向负载 Maximum radial load	N	2000					
容许最大轴向负载 *2 Maximum axial load	N	3500					
效率 Efficiency	%	≥94					
使用环境温度 Use of temperature	°C	<-15°C ~ +40°C>					
使用寿命 Service life	h	≥20000					
润滑 Lubrication *3		合成润滑脂 (终身免保养)					
重量 (大概) Weight	kg	8kg					

减速机输出的几种方式 / Output mode

Output Shaft 实轴	S1 Shaft 光轴	S2 Shaft with key 单键轴
Output Shaft 孔轴	K1 Hollow 光内孔 (带键槽)	K2 Hollow with key 单键内孔
	S3 Splindle shaft 花键轴	S-T Special shaft 特殊轴
		According to customers 根据客户要求定制
	K3 Splindle hollow 花键内孔	K-T Special hollow 特殊内孔
		According to customers 根据客户要求定制

*1. 减速比 $i = N_{in} / N_{out}$ *2. 输出转速为100rpm时, 作用于输出轴中心位置 *3. 可定制高低温油脂

减速机订货选购说明 / Instructions for order and purchase of planetary reducer

WPL 140 L2 - 25 - P2 - S2



motor size

MODEL
系列代号

SIZE
规格

STAGE
段数 (级数)

Ratio i
减速比

Backlash
背隙

Output type
输出安装方式

伺服电机、交流电机、
步进电机、液压马达等

减速机外形尺寸图: 电机输入轴直径 ≤ 35 / Input ≤ 35

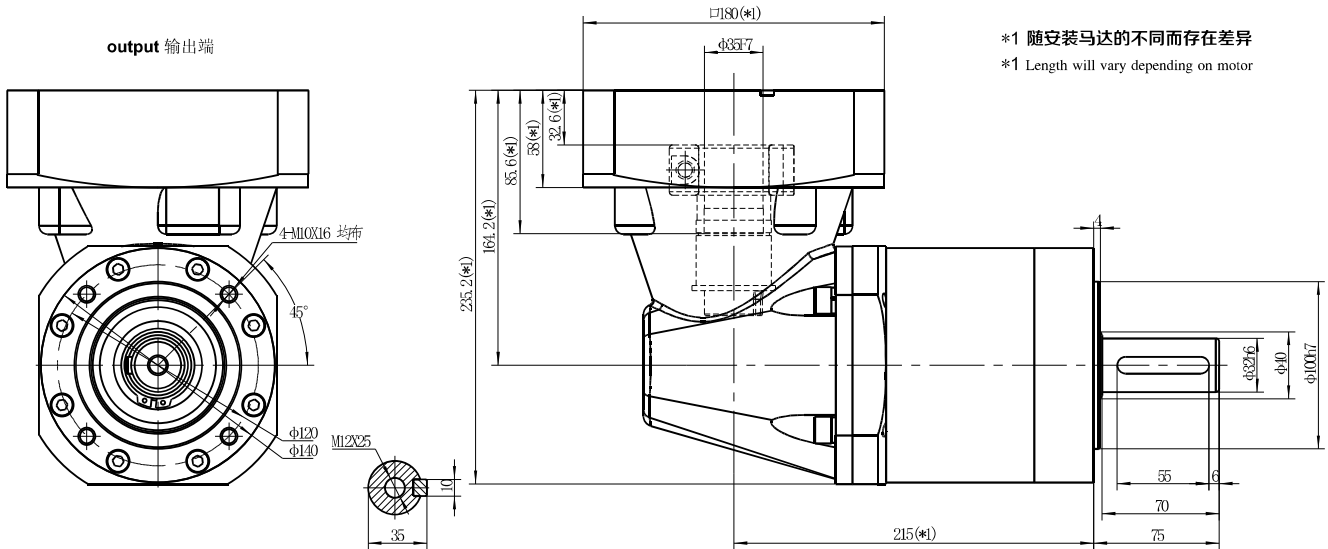

*1 随安装马达的不同而存在差异
*1 Length will vary depending on motor

减速机性能参数 / Performance parameter

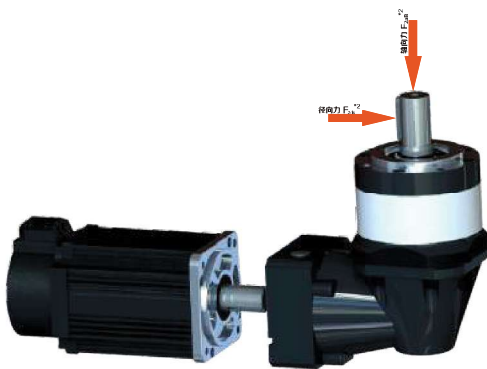

减速机性能参数	减速比 Ratio *1	i 推荐					
		9	12	16	15	25	64
额定输出扭矩 T2N Nominal output torque	Nm	231	452	415	216	80	
最大加速力矩 T2B Maximum acceleration torque	Nm	669	922	577	347	80	
急停扭矩 T2Not Sudden stop torque	Nm	1116	1537	962	579	80	
额定输入转速 Nominal input speed	rpm	3000					
最大输入转速 Maximum input speed	rpm	6000					
精密背隙 Precision backlash	P1-arcmin	≤ 8					
	P2-arcmin	≤ 10					
噪音 Noise	dB(A)	≤ 68					
容许最大径向负载 *2 Maximum radial load	N	2000					
容许最大轴向负载 *2 Maximum axial load	N	3500					
效率 Efficiency	%	≥ 94					
使用环境温度 Use of temperature	°C	<-15°C ~ +40°C>					
使用寿命 Service life	h	≥ 20000					
润滑 Lubrication *3		合成润滑油 (终身免保养)					
重量 (大概) Weight	kg	8kg					

*1. 减速比 $i = N_{in} / N_{out}$ *2. 输出转速为 100rpm 时, 作用于输出轴中心位置 *3. 可定制高低温油脂

减速机输出的几种方式 / Output mode

Output Shaft 实轴	S1	Shaft 光轴	S2	Shaft with key 单键轴
	S3	Spline shaft 花键轴	S-T	Special shaft 特殊轴
			According to customers 根据客户要求定制	
Output Shaft 孔轴	K1	Hollow 光内孔 (空心轴)	K2	Hollow with key 单键内孔
	K3	Spline hollow 花键内孔	K-T	Special hollow 特殊孔
			According to customers 根据客户要求定制	

减速机订货选购说明 / Instructions for order and purchase of planetary reducer

WPL 160 L1 - 5 - P2 - S2



motor size

MODEL
系列代号

SIZE
规格

STAGE
段数 (级数)

Ratio i
减速比

Backlash
背隙

Output type
输出安装方式

伺服电机、交流电机、
步进电机、液压马达等

减速机外形尺寸图: 电机输入轴直径 ≤ 24 / Input ≤ 24

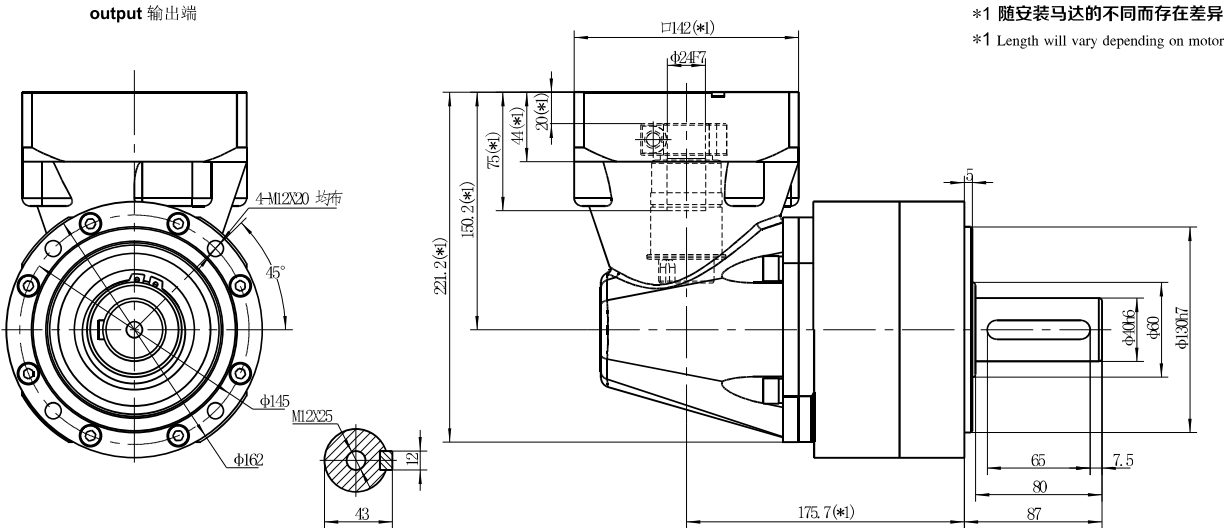

减速机性能参数 / Performance parameter

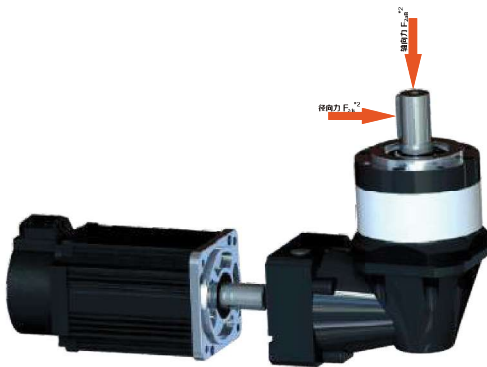

减速比 Ratio *1	i	3	4	5	6	8	10
额定输出扭矩 T2N Nominal output torque	Nm	364	770	635	432	335	192
最大加速力矩 T2B Maximum acceleration torque	Nm	844	1408	889	530	505	318
急停扭矩 T2Not Sudden stop torque	Nm	1407	2348	1482	884	842	530
额定输入转速 Nominal input speed	rpm	2000					
最大输入转速 Maximum input speed	rpm	4000					
精密背隙 Precision backlash	P1-arcmin	≤10					
	P2-arcmin	≤12					
噪音 Noise	dB(A)	≤70					
容许最大径向负载 *2 Maximum radial load	N	3600					
容许最大轴向负载 *2 Maximum axial load	N	8000					
效率 Efficiency	%	≥95					
使用环境温度 Use of temperature	°C	<-15°C ~ +40°C					
使用寿命 Service life	h	≥20000					
润滑 Lubrication *3		合成润滑脂 (终身免保养)					
重量 (大概) Weight	kg	21kg					

*1. 减速比 $i = N_{in} / N_{out}$ *2. 输出转速为100rpm时, 作用于输出轴中心位置 *3. 可定制高低温油脂

减速机输出的几种方式 / Output mode

Output Shaft 实轴	S1	Shaft 光轴	S2	Shaft with key 单键轴
	S3	Spline shaft 花键轴	S-T	Special shaft 特殊轴
	According to customers 根据客户要求定制			
Output Shaft 孔轴	K1	Hollow 光内孔 (空心轴)	K2	Hollow with key 单键内孔
	K3	Spline hollow 花键内孔	K-T	Special hollow 特殊孔
	According to customers 根据客户要求定制			

减速机订货选购说明 / Instructions for order and purchase of planetary reducer

WPL 160 L1 - 5 - P2 - S2



motor size

MODEL
系列代号

SIZE
规格

STAGE
段数 (级数)

Ratio i
减速比

Backlash
背隙

Output type
输出安装方式

伺服电机、交流电机、
步进电机、液压马达等

减速机外形尺寸图: 电机输入轴直径 ≤ 35 / Input ≤ 35

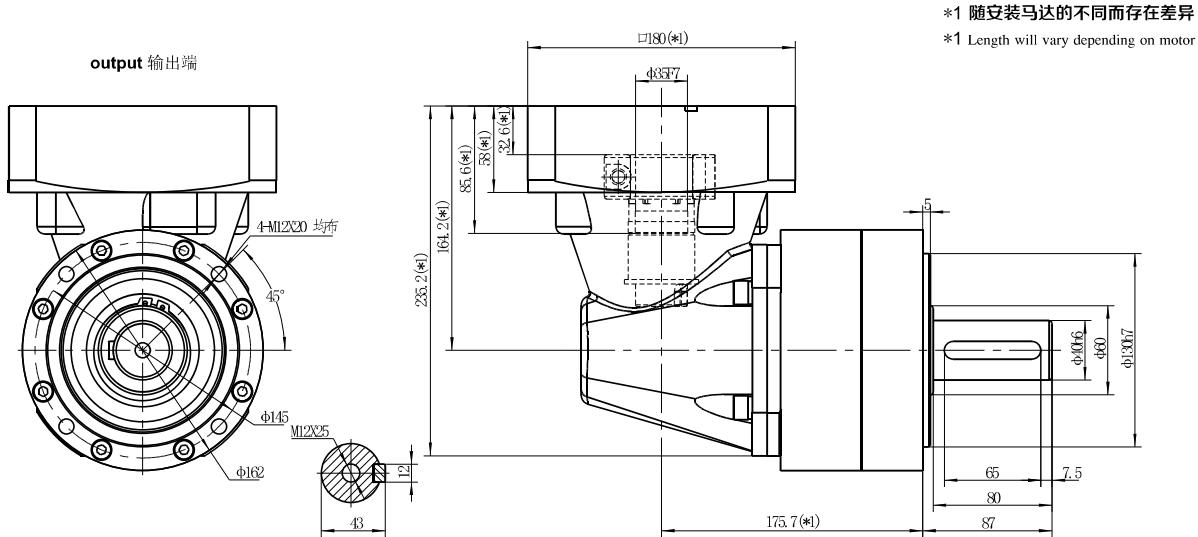

*1 随安装马达的不同而存在差异
*1 Length will vary depending on motor

减速机性能参数 / Performance parameter

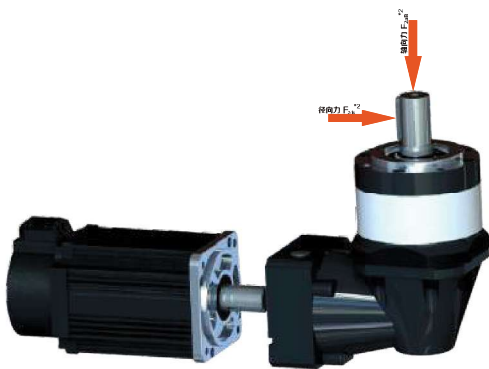

减速比 Ratio *1	i	3	4	5	6	8	10
额定输出扭矩 T2N Nominal output torque	Nm	364	770	635	432	335	192
最大加速力矩 T2B Maximum acceleration torque	Nm	844	1408	889	530	505	318
急停扭矩 T2Not Sudden stop torque	Nm	1407	2348	1482	884	842	530
额定输入转速 Nominal input speed	rpm	2000					
最大输入转速 Maximum input speed	rpm	4000					
精密背隙 Precision backlash	P1 - arcmin	≤ 10					
	P2 - arcmin	≤ 12					
噪音 Noise	dB(A)	≤ 70					
容许最大径向负载 *2 Maximum radial load	N	3600					
容许最大轴向负载 *2 Maximum axial load	N	8000					
效率 Efficiency	%	≥ 95					
使用环境温度 Use of temperature	°C	< -15°C ~ +40°C					
使用寿命 Service life	h	≥ 20000					
润滑 Lubrication *3		合成润滑脂 (终身免保养)					
重量 (大概) Weight	kg	21kg					

*1. 减速比 $i = N_{in} / N_{out}$ *2. 输出转速为 100rpm 时, 作用于输出轴中心位置 *3. 可定制高低温油脂

减速机输出的几种方式 / Output mode

Output Shaft 实轴	S1	Shaft 光轴	S2	Shaft with key 单键轴
	S3	Spline shaft 花键轴	S-T	Special shaft 特殊轴
	According to customers 根据客户要求定制			
Output Shaft 孔轴	K1	Hollow 光内孔 (空心轴)	K2	Hollow with key 单键内孔
	K3	Spline hollow 花键内孔	K-T	Special hollow 特殊孔
	According to customers 根据客户要求定制			

减速机订货选购说明 / Instructions for order and purchase of planetary reducer

WPL 160 L2 - 25 - P2 - S2



motor size

MODEL
系列代号

SIZE
规格

STAGE
段数 (级数)

Ratio i
减速比

Backlash
背隙

Output type
输出安装方式

伺服电机、交流电机、
步进电机、液压马达等

减速机外形尺寸图: 电机输入轴直径 ≤ 24 / Input ≤ 24

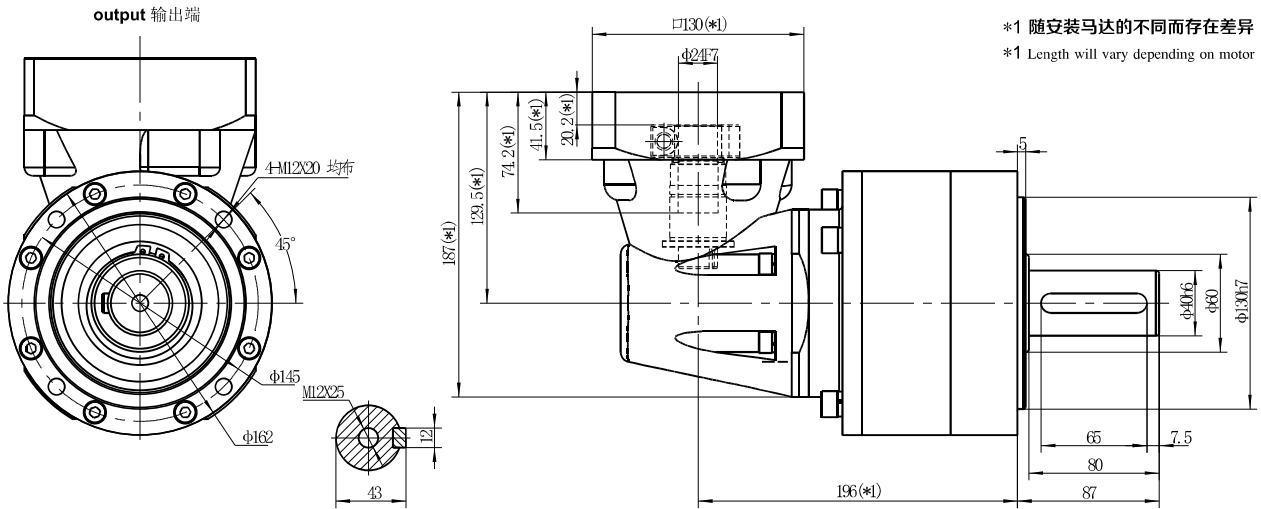

减速机性能参数 / Performance parameter

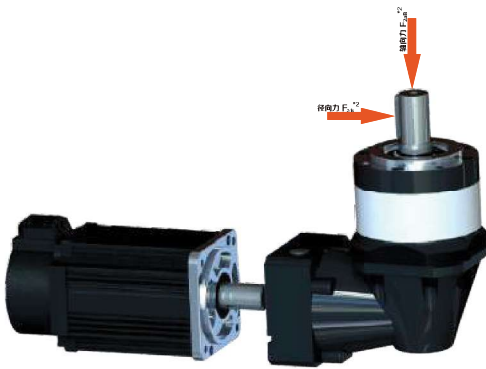

减速比 Ratio *1	i	3	4	5	6	8	10
额定输出扭矩 T2N Nominal output torque	Nm	364	770	635	432	335	192
最大加速力矩 T2B Maximum acceleration torque	Nm	844	1408	889	530	505	318
急停扭矩 T2Not Sudden stop torque	Nm	1407	2348	1482	884	842	530
额定输入转速 Nominal input speed	rpm	2000					
最大输入转速 Maximum input speed	rpm	4000					
精密背隙 Precision backlash	P1 -arcmin	≤10					
	P2 -arcmin	≤12					
噪音 Noise	dB(A)	≤70					
容许最大径向负载 *2 Maximum radial load	N	3600					
容许最大轴向负载 *2 Maximum axial load	N	8000					
效率 Efficiency	%	≥95					
使用环境温度 Use of temperature	°C	<-15°C ~ +40°C					
使用寿命 Service life	h	≥20000					
润滑 Lubrication *3		合成润滑脂 (终身免保养)					
重量 (大概) Weight	kg	21kg					

减速机输出的几种方式 / Output mode

Output Shaft 实轴	S1	Shaft 光轴	S2	Shaft with key 单键轴
	S3	Spline shaft 花键轴	S-T	Special shaft 特殊轴
Output Shaft 孔轴	K1	Hollow 光内孔 (空心轴)	K2	Hollow with key 单键内孔
	K3	Spline hollow 花键内孔	K-T	Special hollow 特殊孔
				According to customers 根据客户要求定制

*1. 减速比 $i = N_{in} / N_{out}$ *2. 输出转速为 100rpm 时, 作用于输出轴中心位置 *3. 可定制高低温油脂

减速机订货选购说明 / Instructions for order and purchase of planetary reducer

WPL 160 L2 - 25 - P2 - S2



motor size

MODEL
系列代号

SIZE
规格

STAGE
段数 (级数)

Ratio i
减速比

Backlash
背隙

Output type
输出安装方式

伺服电机、交流电机、
步进电机、液压马达等

减速机外形尺寸图: 电机输入轴直径 ≤ 35 / Input ≤ 35

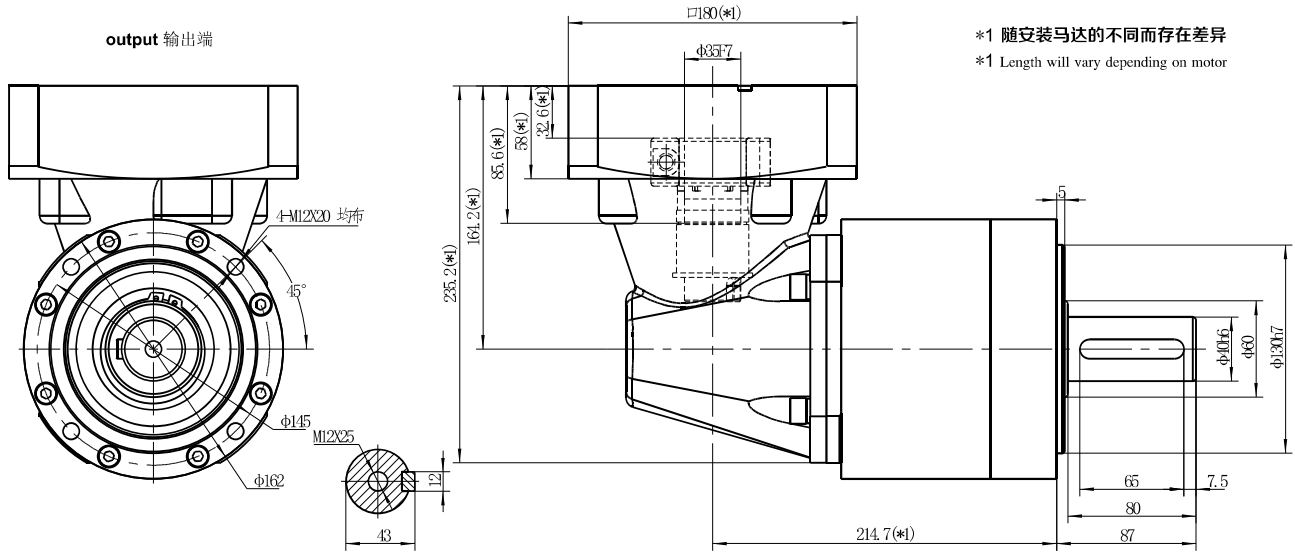

减速机性能参数 / Performance parameter

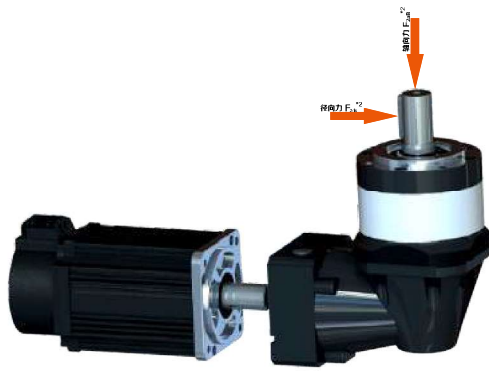

	减速比 Ratio *1	i 推荐					
		9	12	16	15	25	64
额定输出扭矩 T2N Nominal output torque	Nm	364	770	635	335	80	
最大加速力矩 T2B Maximum acceleration torque	Nm	844	1408	889	505		
急停扭矩 T2Not Sudden stop torque	Nm	1407	2348	1482	842		
额定输入转速 Nominal input speed	rpm	2000					
最大输入转速 Maximum input speed	rpm	4000					
精密背隙 Precision backlash	P1-arcmin	≤12					
	P2-arcmin	≤14					
噪音 Noise	dB(A)	≤70					
容许最大径向负载 *2 Maximum radial load	N	3600					
容许最大轴向负载 *2 Maximum axial load	N	8000					
效率 Efficiency	%	≥92					
使用环境温度 Use of temperature	°C	<-15°C~+40°C>					
使用寿命 Service life	h	≥20000					
润滑 Lubrication *3		合成润滑油 (终身免保养)					
重量 (大概) Weight	kg	26kg					

*1. 减速比 $i = N_{in} / N_{out}$ *2. 输出转速为100rpm时, 作用于输出轴中心位置 *3. 可定制高低温油脂

减速机输出的几种方式 / Output mode

Output Shaft 实轴	S1	Shaft 光轴	S2	Shaft with key 单键轴
	S3	Spline shaft 花键轴	S-T	Special shaft 特殊轴
			According to customers 根据客户要求定制	
Output Shaft 孔轴	K1	Hollow 光内孔 (空心轴)	K2	Hollow with key 单键内孔
	K3	Spline hollow 花键内孔	K-T	Special hollow 特殊孔
			According to customers 根据客户要求定制	