



PS00007037A01

GL20-0008ETN Series Digital Output Module User Guide

Suzhou Inovance Technology Co., Ltd.

Add.: No.52, Tian E Dang Road, Wuzhong District,
Suzhou 215104, P.R. China

Tel: (0512) 6637 6666 Fax: (0512) 6285 6720

www.inovance.com



Preface

■ Introduction

GL20-0008ETN series 8-channel digital NPN transistor output module can be used with Easy series PLCs and GL20 series communication interface modules such as GL20-RTU-ECT.

This guide describes the mechanical installation, electrical installation, and program commissioning of the product.

■ Standards Compliance

The following table lists the certifications, directives, and standards that the product may comply with. For details about the acquired certificates, see the certification marks on the product nameplate.

Certification	Directive		Standard
CE Certification	EMC Directive	2014/30/EU	24 VDC products: EN 61131-2 220 VAC products: EN 61131-2 EN 61000-3-2 EN 61000-3-3
	LVD Directive	2014/35/EU	EN 61010-1 EN 61010-2-201
	RoHS Directive	2011/65/EU amended by (EU) 2015/863	EN IEC 63000
UL/cUL Certification	-		UL 61010-1 UL 61010-2-201 UL 61010-2-030 CAN/CSA-C22.2 No. 61010-1 CSA C22.2 NO. 61010-2-201 CSA C22.2 NO. 61010-2-030

Certification	Directive	Standard
KCC Certification	-	-
EAC Certification	-	-

■ More Data

Name	Code	Description
GL20-RTU-ECT32 Series Communication Interface Module User Guide	PS00013434	Introduces the mechanical installation, electrical installation, program commissioning, troubleshooting, and version matching information of the product.
GL20-RTU-ECT Series Communication Interface Module User Guide	PS00004985	
GL20-RTU-EIP Series Communication Interface Module User Guide	PS00014402	
GL20-0008ETN Series Digital Output Module User Guide (This guide)	PS00007037	

■ Revision History

Date	Version	Revision
March 2025	A01	Added: <ul style="list-style-type: none">● Added "<i>1.4 Environmental Specifications</i>" on page 14.● Added "<i>2.1 Installation Precautions</i>" on page 16.● Added "<i>Troubleshooting</i>" on page 28.● Added "<i>Appendix: Version Matching Information</i>" on page 30. Modified: <ul style="list-style-type: none">● Modified the output PDO data volume in "<i>1.3 Technical Specifications</i>" on page 12.● Modified the dimension diagram in "<i>2.1 Installation Precautions</i>" on page 16.● Modified the terminal wiring diagram in "<i>3.3 Terminal Wiring</i>" on page 23.
September 2022	A00	First release.

■ Access to the Guide

This guide is not delivered with the product. You can obtain the PDF version by the following methods:

- Do keyword search under Service and Support at www.inovance.com.
- Scan the QR code on the product with your smart phone.
- Scan the QR code below to install My Inovance app, where you can search for and download user guides.



■ Warranty Disclaimer

The warranty period of the product is 18 months as of the date of manufacture (refer to the barcode on the equipment). If otherwise agreed upon, the agreed terms and conditions shall prevail. After the warranty period expires, maintenance will be charged.

The warranty does not cover any damage caused by:

- Damage caused by operations not following the instructions in the user guide
- Damage caused by fire, flood, or unusual voltage
- Damage caused by unintended use of the product
- Damage caused by use beyond the specified scope of application of the product
- Damage or secondary damage caused by force majeure (natural disaster, earthquake, and lightning strike)

The maintenance is charged according to the latest Price List of Inovance. If otherwise agreed upon, the terms and conditions in the agreement shall prevail.

For details, see the Product Warranty Card.

Safety Precautions

■ Safety Disclaimer

1. Read and follow the safety instructions when installing, operating, and maintaining the equipment.
2. To ensure your safety and prevent damage to the equipment, follow the marks on the equipment and all the safety instructions in this guide.
3. "CAUTION", "WARNING", and "DANGER" items in the guide do not indicate all safety precautions that need to be followed; instead, they just supplement the safety precautions.
4. Use this equipment according to the designated environment requirements; otherwise, a fault may occur. Malfunction or damage caused by improper use is not covered by warranty.
5. Inovance shall take no responsibility for any personal injury or property damage caused by improper use.

■ Safety Levels and Definitions

 **DANGER**: "DANGER" indicates that failure to comply with the notice can result in severe personal injury or even death.

 **WARNING**: "WARNING" indicates that failure to comply with the notice may result in severe personal injury or even death.

 **CAUTION**: "CAUTION" indicates that failure to comply with the notice may result in minor or moderate personal injury or equipment damage. Keep this user guide properly for future use and deliver it to the end user.

Control System Design

 **DANGER**

- Provide a safety circuit outside the PLC so that the control system can still work safely once external power failure or controller fault occurs.
- Add a fuse or circuit breaker because the module may smoke or catch fire due to long-time overcurrent caused by operation above rated current or load short-circuit.



- An emergency stop circuit, a protection circuit, a forward/reverse operation interlocked circuit, and an upper position limit and lower position limit interlocked circuit must be set in the external circuits of PLC to prevent damage to the equipment.
- To ensure safe operation, for the output signals that may cause critical accidents, use external protection circuits and safety mechanism.
- Once the CPU of the controller detects an exception in the system, all outputs may be closed. When a fault occurs in the controller circuit, the output may not be under control. Therefore, it is necessary to set up an external control circuit to ensure normal operation.
- If the output units such as relays or transistors are damaged, the output may fail to switch between ON and OFF states according to the commands.
- The PLC is designed to be used in an indoor electrical environment (overvoltage category II). The power supply must have a system-level surge protector, assuring that overvoltage due to lightning shock cannot be applied to the PLC's power supply input terminals, signal input terminals, and output terminals, to prevent damage to the equipment.

Installation



- Installation must be carried out by skilled personal who have undergone specialized electrical training and possess comprehensive electrical expertise.
- Disconnect all external power supplies of the system before disassembling the module. Failure to do so may result in electric shock, module fault, or malfunction.
- Do not use the PLC in environments with dust, greasy smoke, conductive dust, corrosive or combustible gases, exposed to high temperature, condensation, wind & rain, or subject to vibration and shock. Electric shock, fire, and malfunction may also result in damage or deterioration to the product.
- The PLC is open-type equipment that must be installed in a control cabinet with lock (cabinet housing protection > IP20). Only the skilled personnel who have undergone specialized electrical training and possess comprehensive electrical expertise can open the cabinet.



- Prevent metal filings and wire ends from dropping into ventilation holes of the PLC during installation. Failure to comply may result in fire, fault, and malfunction.
- Ensure there are no unwanted matters on ventilation surface. Failure to comply may result in poor ventilation, which may cause fire, fault, and malfunction.
- Ensure the module is connected to the respective connector securely and hook the module firmly. Improper installation may result in malfunction, fault, or fall-off.

Wiring



- Wiring must be carried out by skilled personnel who have undergone specialized electrical training and possess comprehensive electrical expertise.
- Disconnect all external power supplies of the system before wiring. Failure to comply may result in electric shock, module fault, or malfunction.
- Install the terminal cover attached to the product before power-on or operation after wiring is done. Failure to comply may result in electric shock.
- Insulate the cable terminals properly to ensure the insulation distance between cables will not be shortened after cables are connected to the terminal block. Failure to comply may result in electric shock or damage to the equipment.



- To avoid electric shock, cut off the power supply before connecting the product to the power supply.
- The input power of the product must meet the specifications listed in this guide. If the power input does not meet the specifications, the equipment may be damaged. Thus, check regularly that the DC power provided by the switching-mode power supply unit is stable.

Operation and Maintenance



- Operation and maintenance must be carried out by skilled personnel who have undergone specialized electrical training and possess comprehensive electrical expertise.
- Do not touch the terminals while the power is on. Failure to comply may result in electric shock or malfunction.
- Disconnect all external power supplies of the system before cleaning the module. Failure to comply may result in electric shock.
- Disconnect all external power supplies of the system before assembling/disassembling the module or connecting/removing the communication cables. Failure to comply may result in electric shock or malfunction.

Safety Recommendations

- In the position where the operator directly touches the machinery part, for example, where a machinery tool is loaded/unloaded, or where a machine runs automatically, the on-site manual operating devices and any other alternative means must be carefully arranged and designed so that they are independent of the PLC and can start or terminate the automatic running of the system.
- If modification on the program is needed during system operation, use the lock function or other protective measures. Ensure that only authorized personnel can make the necessary modifications.

Disposal



- Treat the scrapped product as industrial waste. Dispose of the battery according to local laws and regulations.
- Recycle retired equipment by observing industry waste disposal standards to avoid environmental pollution.

1 Product Information

1.1 Naming Rules and Nameplate

GL 20 -00 08 E TN

①

②

③

④

⑤

⑥

① **Product Information**

GL: Inovance general
local module

③ **Number of Input
Channels**

00: 0 input
channel

⑤ **Module Type**

E: Logic I/O expansion
module

② **Series Number**

20: 20 series module

④ **Number of
Output Channels**

08: 8 output
channels

⑥ **Output Type**

R: Relay output
TP: Transistor output
(source mode)
TN: Transistor output (sink
mode)

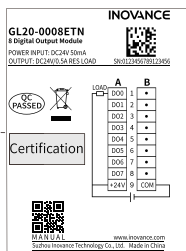





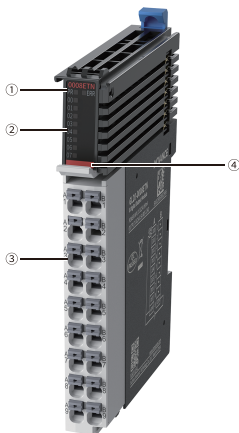

The data for ordering the product is shown in the following table.

Model	Description	Material Code	Applicable Model
GL20-0008ETN	GL20-0008ETN series 8-channel digital NPN transistor output module	01440379	Easy series products and GL20 series communication interface modules such as GL20-RTU-ECT

1.2 Components



No.	Name	Description			
①	Signal indicator	PR (POWER +RUN)	Power/Operation indicator	Yellow- green	Steady ON: The module is in normal operation. Flashing: The module is preparing or stopped. OFF: The module is faulty.
		ERR	Fault indicator	Red	ON when the module is faulty. For details, see " Troubleshooting " on page 28 .
②	I/O signal indicator	Corresponding to various input signals, ON: input active OFF: input inactive			
③	I/O terminals	For details, see " 3.2 Terminal Definition " on page 22 .			

No.	Name	Description	
④	Color identification	 Red: Digital output	 Orange: Analog output
		 Gray: Digital input	 Green: Analog input
		 White: Communication	 Blue: Other modules

Note

Flashing: The indicator is on for 200 ms and off for 200 ms, repeating this cycle.

1.3 Technical Specifications

■ Power supply specifications

Item	Specification
Rated voltage of bus input power supply	5 VDC (4.75 VDC to 5.25 VDC)
Rated current of bus input power supply	115 mA (typical value @5 V)
Rated voltage of terminal input power supply	24 VDC (20.4 VDC to 28.8 VDC)
Rated current of terminal input power supply	50 mA (typical value @24 V)
Rated voltage of terminal output power supply	/
Rated current of terminal output power supply	/
Hot swap	Not supported

■ Output specifications

Item	Specification
Output type	Digital output, low side transistor output
Output mode	Sink mode
Number of output channels	8

Item	Specification
Output voltage class	24 VDC \pm 10% (21.6 VDC to 26.4 VDC)
Output load (resistive load)	0.5 A/channel; 2 A/module
Output load (inductive load)	7.2 W/channel; 12 W/module
Output load (lamp load)	5 W/channel; 9 W/module
Hardware response time upon ON/OFF	100 μ s/100 μ s
Leakage current upon OFF	10 μ A
Switching frequency	Resistive load: 100 Hz; inductive load: 0.5 Hz; lamp load: 10 Hz
Isolation	Isolated
Output indicator	The output indicator turns on (controlled by software) when the output is in drive state.
Output derating	Not supported
Protective functions	Short circuit protection, overcurrent protection

■ Software specifications

Item	Specification
Output PDO data volume	Max. 1 byte
Output state mode during fault stop	Output zero, last value, or preset value
Preset value output during fault stop	0 or 1
Output terminal fault detection and indication	Not supported
Output channel logic level configuration	Not supported
Independent channel enable configuration	Not supported
Diagnostic report function configuration	Not supported

Item	Specification
Output in the stop mode	Output zero, last value, or preset value according to the output state mode during fault stop, without further refreshing.
I/O mapping	Support bitwise, byte-wise, and word-wise I/O mapping modes

Note

Stop at fault refers to:

- Background start/stop;
- The bus of GL20 communication interface module is out of communication due to disconnection of the network cable or manual state switching;
- The local bus stops operation.

1.4 Environmental Specifications

Item	Specification
Installation/application environment	Free from conductive dust, conductive fibers, explosive dust, flammable gases, water mist/greasy dirt, corrosive dusts/gases, strong vibration, and repetitive shock
Altitude	≤ 2,000 m
Pollution degree	2
Immunity	2 kV on power supply cable (compliant with IEC 61000-4-4)
Overvoltage category	I
EMC immunity level	Zone B, IEC61131-2
Anti-static rating	Contact discharge +/-6 kV and air discharge +/-8 kV
Vibration resistance	<ul style="list-style-type: none"> • Application scenario: Tested according to IEC60068-2-6, 3.5 mm amplitude from 5 Hz to 8.4 Hz; 1 g acceleration from 8.4 Hz to 200 Hz; 10 cycles per axial direction • Transportation scenario: Tested according to IEC60068-2-64, 0.01 g²/Hz power spectral density from 5 Hz to 100 Hz; 0.001 g²/Hz power spectral density at 200 Hz; 1.14 g Grms

Item	Specification
Shock resistance	Application/Transportation scenario: Tested according to IEC60068-2-27; 15 g peak acceleration, 11 ms pulse width, 18 cycles in total in X, Y and Z axial directions
Operating temperature/humidity	<ul style="list-style-type: none"> ● Temperature: -20°C to +55°C ● Humidity: < 95% RH (30°C), without condensation
Storage temperature/humidity	<ul style="list-style-type: none"> ● Temperature: -20°C to +60°C ● Humidity: < 95% RH (30°C), without condensation
Transportation temperature/humidity	<ul style="list-style-type: none"> ● Temperature: -40°C to +70°C ● Humidity: < 95% RH (40°C), without condensation

2 Mechanical Installation

2.1 Installation Precautions

- Make sure the module is powered off before installing or removing.
- Do not hot swap the modules. Otherwise, the modules may be damaged by overcurrent or overvoltage, and the communication interface module or PLC may be subject to restart, user data loss or corruption.
- Do not drop or shock the housing or terminals of the module to avoid damage.

2.2 Installation Dimensions

■ Module

The installation dimensions (in mm) are shown in the figure below.

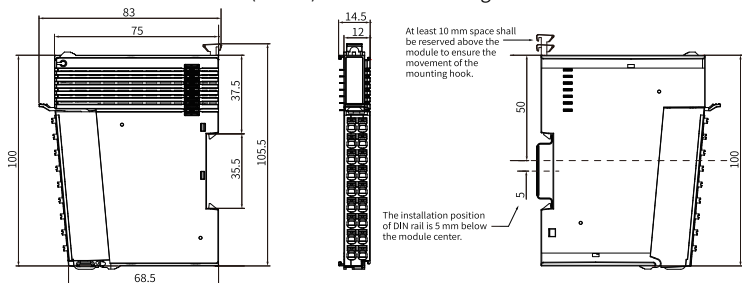

■ Cable connection

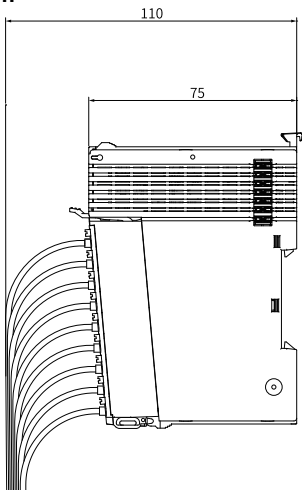

2.3 Installation Method

The module is mounted onto a DIN rail according to IEC 60715 (width: 35 mm, thickness: 1 mm). The dimensions (in mm) are shown below.

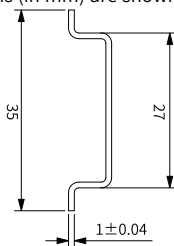



Caution

If the thickness of the DIN rail is not as required, the product cannot fit in or function properly as the DIN rail mounting hook does not work.

■ Installing modules side by side

Install modules side by side by sliding them along the top and bottom guide rails of adjacent modules.

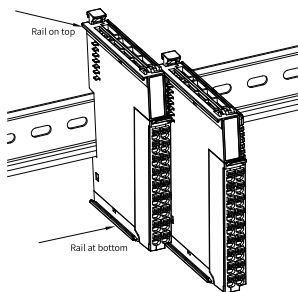

■ Installing modules onto DIN Rail

1. Align the module with the DIN rail and push the module in the direction indicated by the arrow until you hear a click, as shown below.

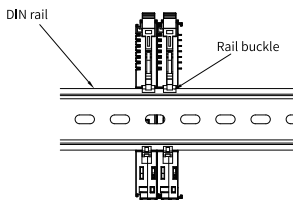
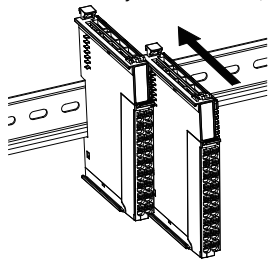

2. Make sure the DIN rail mounting hook of the module is locked. The locked and unlocked states of the mounting hook are shown below.

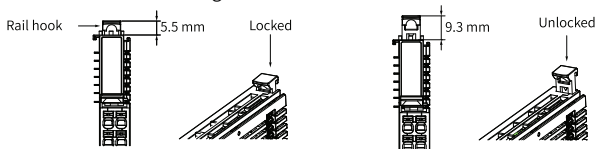

- If the mounting hook is pressed down, it is locked.
- If the mounting hook is lifted up, it is unlocked.

To lock the module to the DIN rail, press down the mounting hook.



When the module is not installed on the DIN rail, keep the rail hook in locked state. A hook that kept in unlocked state for a long period of time may fail to function properly.

3. Install a DIN rail end plate on both sides of the PLC or the module.

To install the end plate, hook the bottom of it to the bottom of the DIN rail, rotate the end plate to hook the top of it to the top of the DIN rail, and then tighten the screw to lock the end plate in place,

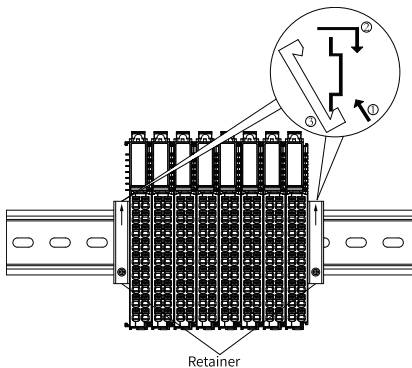

■ Removing modules

Pry the DIN rail mounting hook upwards with a tool such as slotted screwdriver, hold the protrusions and pull the module out straight forward, and then press down the top of the DIN rail mounting hook.

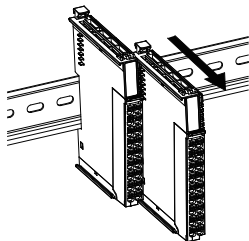
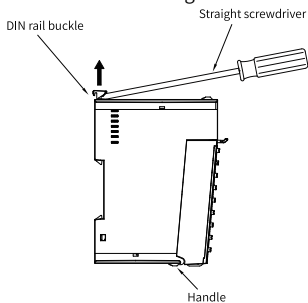

3 Electrical Installation

3.1 Cable Selection

The cable lug and cable diameter included in the following table are only for reference.

Material Name	Applicable Cable Diameter		KST		Suzhou Yuanli	
	mm ²	AWG	Model	Crimping tool	Model	Crimping tool
Tubular lug	0.3	22	E0308	KST2000L	0308	YAC-5
	0.5	20	E0508		0508	
	0.75	18	E7508		7508	
	1.0	18	E1008		1008	
	1.5	16	E1508		1508	

To use other types of tubular lugs, crimp the lug to the cables according to the shape and dimension requirements shown below.

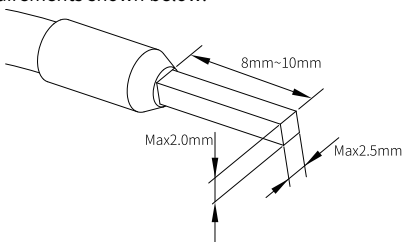

3.2 Terminal Definition



Left Indicator	Left Signal	Left Terminal	Right Terminal	Right Signal	Right Indicator
00	DO0	A1	B1	•	/
01	DO1	A2	B2	•	/
02	DO2	A3	B3	•	/
03	DO3	A4	B4	•	/
04	DO4	A5	B5	•	/
05	DO5	A6	B6	•	/
06	DO6	A7	B7	•	/
07	DO7	A8	B8	•	/
/	24V	A9	B9	COM	/

3.3 Terminal Wiring

This section introduces the wiring precautions and circuit block diagram of the GL20-0008ETP digital output module.

■ Wiring precautions

- Do not bundle the expansion cable together with power cables (with high voltage, large current) that produce strong interference signals; otherwise, the expansion cable may be influenced by noise, surge, and induction. Separate it from other cables and avoid cabling in parallel.
- Use recommended cables and adapter boards for connection. It is recommended that shielded cables be used as expansion cables to enhance anti-interference capacity.
- Apply single-point grounding for the shielding of shielded cable and solder sealed cable.

■ Circuit block diagram and wiring diagram

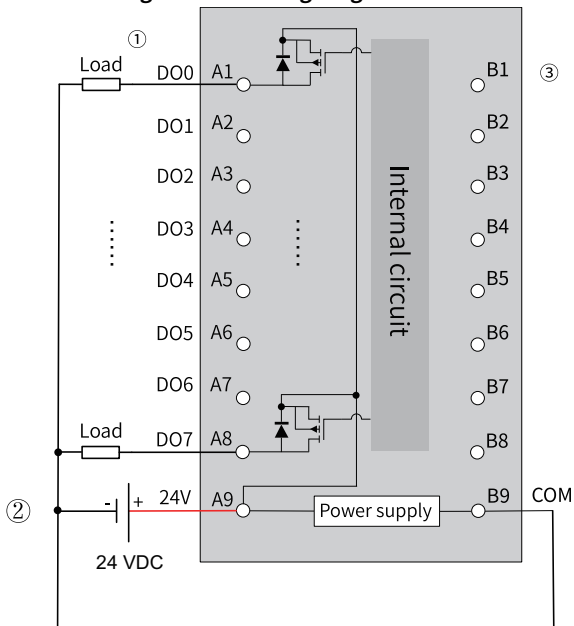

No.	Remark
①	Wiring of output terminals (A1 to A8)
②	Wiring of power supply (A9 and B9)
③	Unused terminals (B1 to B8)

4 Program Commissioning

The following is an example where the variable of the GL20-0008ETN module is assigned to the corresponding output variable, and the AM600 series PLC is used as the master control module.

1. Add the GL20-0008ETN module.

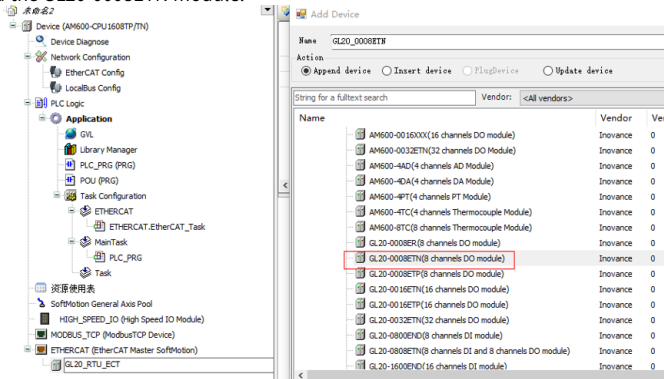

2. Double-click the GL20-0008ETN module in the left **Devices** pane and set the **Out Status after stop or disconnection** on the **Channels Config** tab.

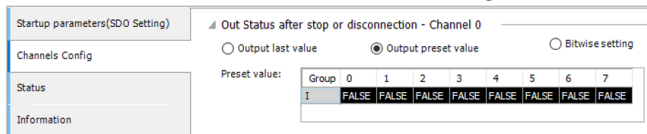

The **Out Status after stop or disconnection** refers to the output mode of the output channel of the module in non-OP state (when the module is stopped or the coupler is disconnected). The following options are supported:

- **Output last value:** All channels in the corresponding group retain the output state before module stop or network disconnection.
- **Output preset value:** The output mode of each channel in the corresponding group matches the preset values. The preset value is matched by bit, with one bit representing one channel.

For example, if bit0 is set to FALSE, the output state of channel 0 is 0; if bit0 is set to TRUE, the output state of channel 0 is 1.

- **Bitwise setting:** The output mode of each channel in the corresponding group is matched by bit, with one bit representing one channel. For example, bit0 represents channel 0.

If bit0 is set to TRUE, channel 0 outputs according to its preset value. If bit0 is set to FALSE, channel 0 retains the last output state.

3. Add a custom output variable "CH0". Set the scope of "CH0" to "VAR" and data type to "INT".

	Scope	Name	Address	Data type	Initialization	Persistent	Constant	Comment	Attributes
1	VAR_GLOBAL	CH0		INT		<input type="checkbox"/>	<input type="checkbox"/>		

4. Map "CH0" to channel 0 of the configured module.

Variable	Mapping	Channel	Address	Type	Default Value	Unit	Description
		Device control	%QW1	UINT			Device control
Application.CH0		GL20_0008ETH Digital output 8bit	%QB4	USINT			GL20_0008ETH Digital output 8bit
		LBus status	%IW1	UINT			LBus status
		Fault ID	%IW2	UINT			Fault ID

5. Define a variable "D0" with the LD programming language.

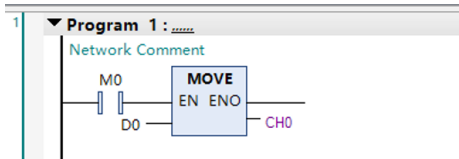

6. Double-click **PLC_PRG** in the left **Devices** pane and complete the programming on the **PLC_PRG** page.
7. Check, compile, log in, download, and run the program.

- a. Click on the toolbar at the top of the interface to check whether the program is correct.
- b. Click on the toolbar to compile all the code into PLC executable code.
- c. Click on the toolbar, and follow the interface prompts to log in to the PLC and download the program.

d. Click  on the toolbar to execute the program.

5 Troubleshooting

When the ERR indicator is ON, it indicates that the module is faulty. The module reports a fault code. You can get the fault code through the diagnostic data object dictionary value displayed on the **CoE Online** interface, as shown below. For the module installed in slot n (n=0-31), the object dictionary definition for index 0xA000 + 0x40*n is shown in the table below.

General Read this page Auto Update Offline from ESI file Online from device

Process Data(PDO Setting)

Startup parameters(SDO Setting)

Online

CoE Online

Device Diagnosis

EtherCAT I/O Mapping

EtherCAT IEC Objects

Status

Information

Index:Subindex	Name	Flags	Type	Value
16#1000:16#00	Device type	RO	UDINT	
16#1001:16#00	Error Register	RO	USINT	
16#1008:16#00	Device Name	RO	STRING(16)	
16#1009:16#00	Hardware version	RO	STRING(16)	
16#100A:16#00	Software version	RO	STRING(16)	
* 16#1018:16#00	Identity	RO	USINT	
* 16#1C00:16#00	Sync manager type	RO	USINT	
* 16#1C12:16#00	RxPDO assign	RO	USINT	
* 16#1C13:16#00	TxPDO assign	RO	USINT	
* 16#1C32:16#00	SM output parameter	RO	USINT	
* 16#1C33:16#00	SM input parameter	RO	USINT	
* 16#3010:16#00	Port 0 error counter	RO	USINT	
* 16#3011:16#00	Port 1 error counter	RO	USINT	
* 16#3012:16#00	ESC error counter	RO	USINT	
* 16#3016:16#00	Station address	RO	USINT	
16#3020:16#00	Fpga soft version	RO	UDINT	
* 16#3021:16#00	Module software version	RO	USINT	
* 16#7000:16#00	0008ETN output	RO	USINT	
* 16#8000:16#00	0008ETN module configure stopmode parameters	RW	USINT	
* 16#8001:16#00	0008ETN module configure stopvalue parameters	RW	USINT	
* 16#A000:16#00	0008ETN Diagnosis information	RO	USINT	
:16#01	0008ETN Module Diagnosis information	RO	UINT	
:16#02	0008ETN CH0 Diagnosis information	RO	UINT	
* 16#F000:16#00	Modular device profile	RO	USINT	
* 16#F030:16#00	Configured Module Ident List	RO	USINT	
* 16#F050:16#00	Detected Module Ident List	RO	USINT	
* 16#F100:16#00	Device Status	RO	USINT	
* 16#F110:16#00	Module Error Flag	RO	USINT	
* 16#F120:16#00	LBus Count	RO	USINT	
* 16#F800:16#00	Device configuration data	RO	USINT	
16#FB00:16#00	Control word	RW	UINT	

Index	0xA000+0x40*n: 08008ETN Diagnostic Information				
Subindex	Name	Data Type	Access Mode	Mapping	Default Value
0	0008ETN module diagnosis information	USINT	RW	Not supported	2
1	0008ETN module fault information	UINT	RO	Not supported	0
2	0008ETN CH0 diagnosis information	UINT	RO	Not supported	0

■ Module fault code

Code	Description	Solution
0x5003	External 24 V power supply failure	Check the isolated power supply of the module.

6 Appendix: Version Matching Information

Contact Inovance technical support to obtain the firmware of GL20-0008ETN module and the firmware of communication interface module. XML files and the AutoShop/InoProShop software can be downloaded from the software and debugging tools tab on the GL20 series product page at <https://www.inovance.com>. The following table describes the version matching information.

Module Firmware Version	Communication Interface Module Firmware Version	XML/GSD File Version	AutoShop/InoProShop Version
Logic software: 0.1.2.0 and later	<ul style="list-style-type: none">● GL20-RTU-ECT: Board software 2.4.13.0 and later● GL20-RTU-EIP: Board software 1.1.6.0 and later	<ul style="list-style-type: none">● GL20-RTU-ECT: 1.3.9.0 and later● GL20-RTU-EIP: V00.01 and later	<ul style="list-style-type: none">● AutoShop: V4.6.5.0 and later● InoProShop: V1.7.3 SP5 and later