

**21000 Series
Size 8 Hybrid Linear Actuators**

Size 8 Hybrid Precision Stepper Motor is part of our extensive, award winning miniature motor product line and is one of the world's smallest linear actuators.

More Compact Option for Motion Applications

The 21000 Series Size 8 Linear Actuator occupies a minimal 0.8" (21 mm) space and includes numerous patented innovations that provide customers high performance and endurance in a very small package.

The 21000 Series is available in a wide variety of resolutions - from 0.00006" (.0015mm) per step to 0.00157" (0.04 mm) per step.

The Size 8 Actuator delivers thrust of up to 10 lbs (44N)

In this new standard design, the anti-rotation spline shaft and plain bushing of our popular Captive-style actuator is upgraded with a recirculating ball spline bushing assembly. The result is an impressive increase in the radial stiffness and/or position stability of the extending output shaft

This makes our Ball Spline Captive perfect for applications such as tip-tilt or rotational alignment of optical devices for:

- Highly dynamic operation, such as tracking, scanning, image stabilization, elimination of drift and vibration
- Static positioning of optical systems and samples

And as will all HKP Captive Actuators:

- Reduced size footprint compared to externally guided solutions
- A wide range from fine to coarse resolution options
- Highly configurable and customizable



Size 8 Ball Spline Captive Shaft

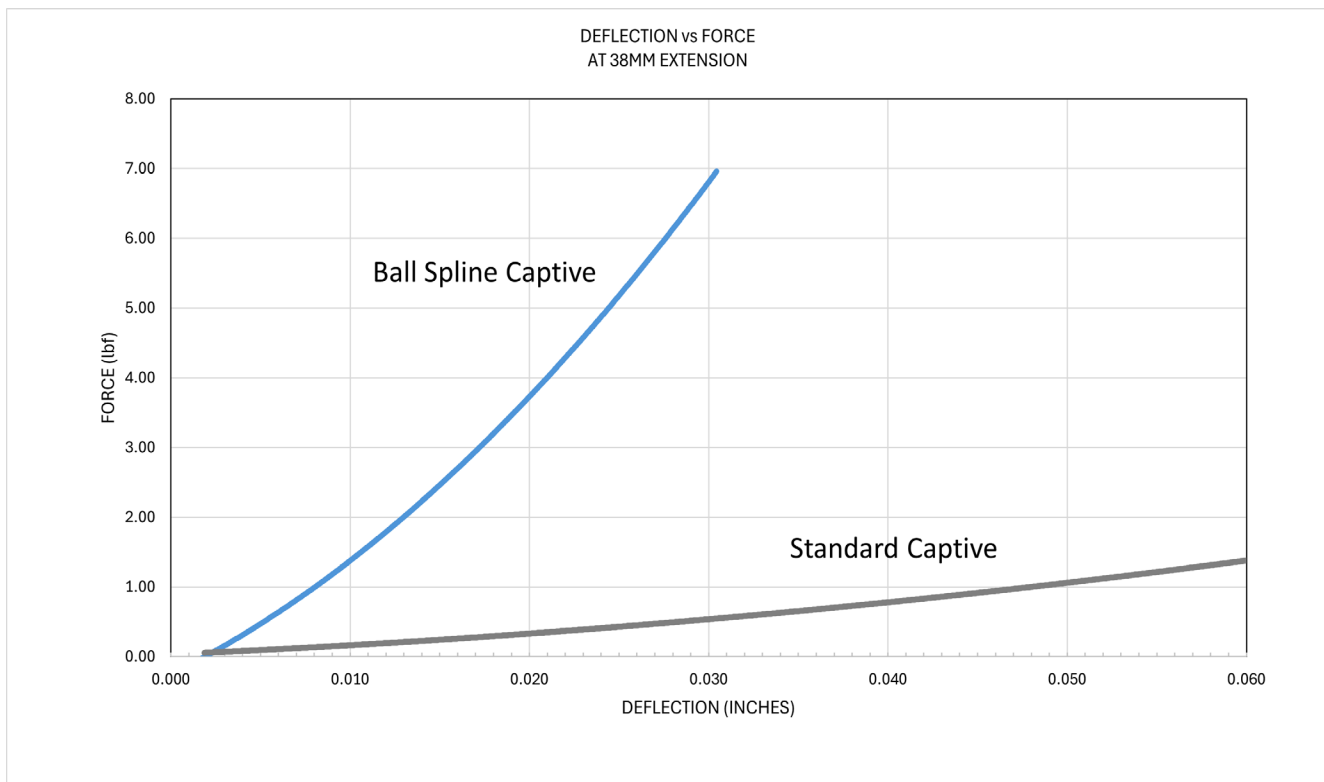

Specifications

Size 8: 21 mm (0.8-in) Hybrid Linear Actuator (1.8° Step Angle)			
Part No.	Captive	BSC21H4 ■ ■ ■ ■ ■ ■ †	
Wiring	Bipolar		
Winding Voltage	2.5 VDC	5 VDC	7.5 VDC
Current (RMS)/phase	.49 A	.24 A	.16 A
Resistance/phase	5.1 Ω	20.4 Ω	45.9 Ω
Inductance/phase	1.5 mH	5.0 mH	11.7 mH
Power Consumption	2.45 W Total		
Rotor Inertia	1.4 gcm ²		
Insulation Class	Class B (Class F available)		
Weight	1.5 oz (43 g)		
Insulation Resistance	20 MΩ		

†Part numbering information on page 4

Linear Travel / Step		Order Code I.D.
Screw Ø.14-in (3.56mm)		
inches	mm	
.00006	.0015*	U**1
.000098*	.0025	AA**
.00012	.0030*	N
.00019*	.005	AB
.00024	.006*	K
.00039*	.01	AC
.00048	.0121*	J
.00078*	.02	AD
.00157	.04	AE

*Before we can provide a quote for the U resolution, we'll need you to speak with an applications engineer

*Values truncated

**TFE coating not available

Standard motors are Class B rated for maximum temperature of 130°C.

Special drive considerations may be necessary when leaving shaft fully extended or fully retracted.

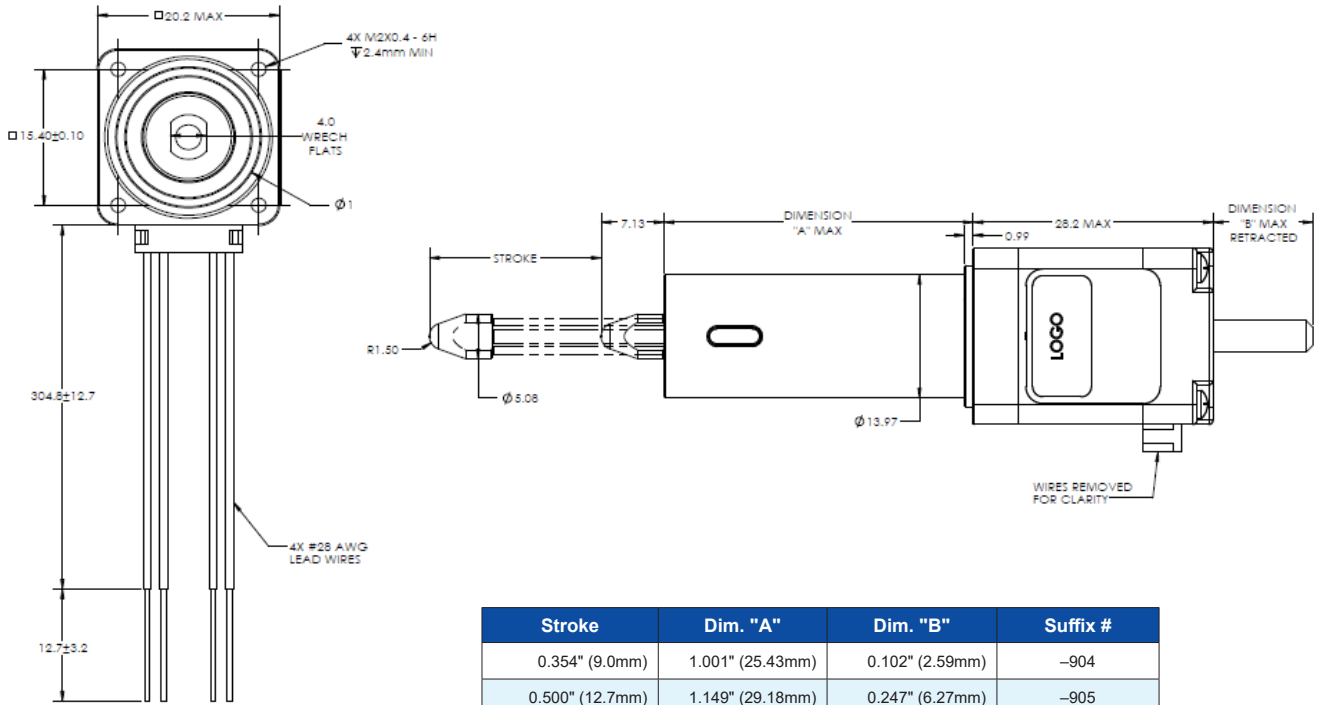

Stroke	Dim. "A"	Dim. "B"	Suffix #
0.354" (9.0mm)	1.001" (25.43mm)	0.102" (2.59mm)	-904
0.500" (12.7mm)	1.149" (29.18mm)	0.247" (6.27mm)	-905
0.750" (19.05mm)	1.395" (35.43mm)	0.496" (12.61mm)	-907
1.000" (25.4mm)	1.651" (41.93mm)	0.746" (18.96mm)	-910
1.250" (31.8mm)	1.897" (48.18mm)	0.996" (25.31mm)	-912
1.500" (38.1mm)	2.143" (54.43mm)	1.247" (31.67mm)	-915

FORCE vs. PULSE RATE

- Chopper
- Bipolar
- 100% Duty Cycle
- Ø .14 (3.56) Lead Screw

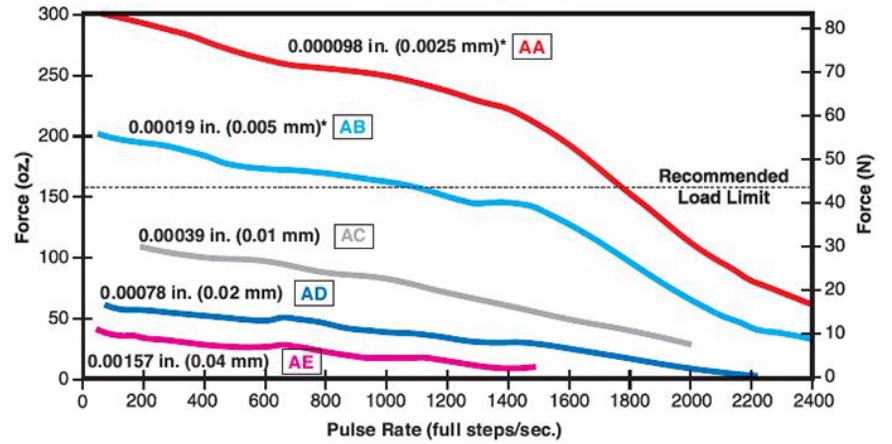
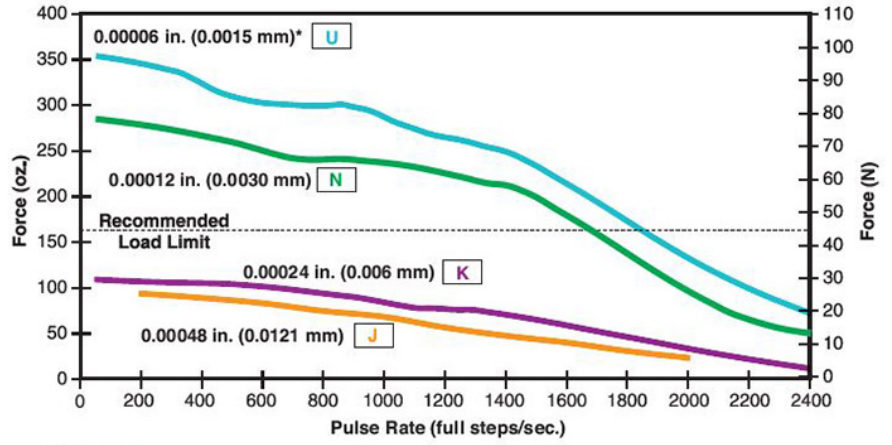

FORCE vs. LINEAR VELOCITY

- Chopper
- Bipolar
- 100% Duty Cycle
- Ø .14 (3.56) Lead Screw

*Care should be taken when utilizing these screw pitches to ensure that the physical load limits of the motor are not exceeded. Please consult the factory for advice in selecting the proper pitch for your application.

NOTE: All chopper drive curves were created with a 5 volt motor and a 40 volt power supply.

Ramping can increase the performance of a motor either by increasing the top speed or getting a heavier load accelerated up to speed faster. Also, deceleration can be used to stop the motor without overshoot.

With L/R drives peak force and speeds are reduced, using a unipolar drive will yield a further 30% force reduction.

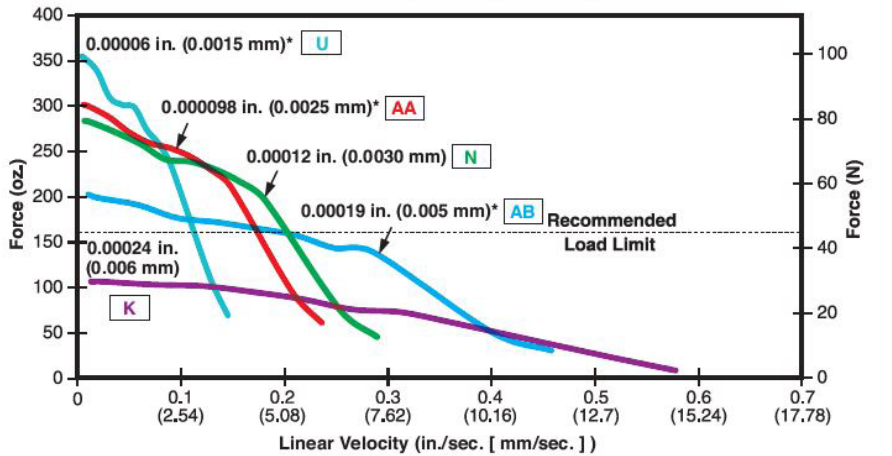
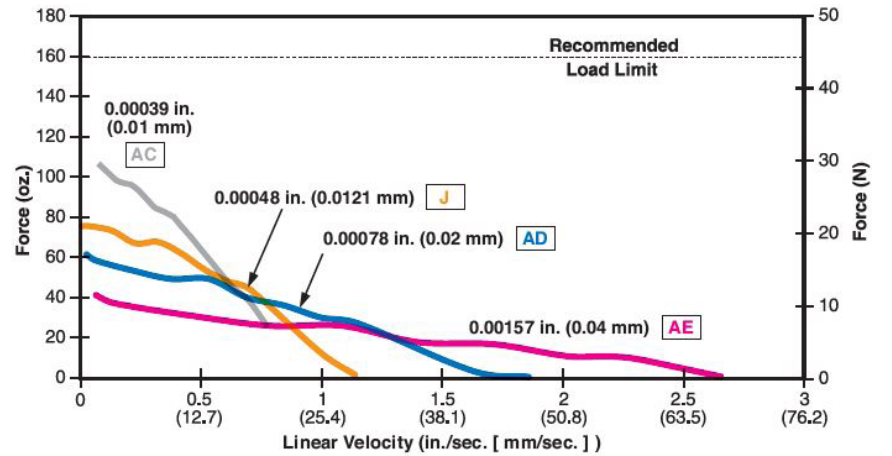

Identifying the Hybrid Part Number Codes when Ordering

BSC	21	H	4	AB	7.5	910
Prefix (include only when using the following) BSC = Ball Spline Captivel	Series Number Designation 21 = 21000 (Series numbers represent approximate width of motor body)	Style H = 1.8° Captive	Coils 4 = Bipolar (4 wire)	Code ID Resolution Travel/Step U*1 = .00006-in (.0015) AA* = .000098-in (.0025) N = .00012-in (.0030) AB = .00019-in (.005) K = .00024-in (.006) AC = .00039-in (.01) J = .00048-in (.0121) AD = .00078-in (.02) AE = .00157-in (.04) *TFE not available 1Before we can provide a quote for the U resolution, we'll need you to speak with an applications engineer.	Voltage 2.5 = 2.5 VDC 05 = 5 VDC 7.5 = 7.5 VDC Custom V available	Suffix Stroke Example: -910 = 1-in (Refer to Stroke chart on Captive motor series product page.) -XXX = Proprietary suffix assigned to a specific customer application. The identifier can apply to either a standard or custom part.

NOTE: Dashes must be included in Part Number (-) as shown above. For assistance call our Engineering Team at 203 756 7441

Hybrids: Wiring

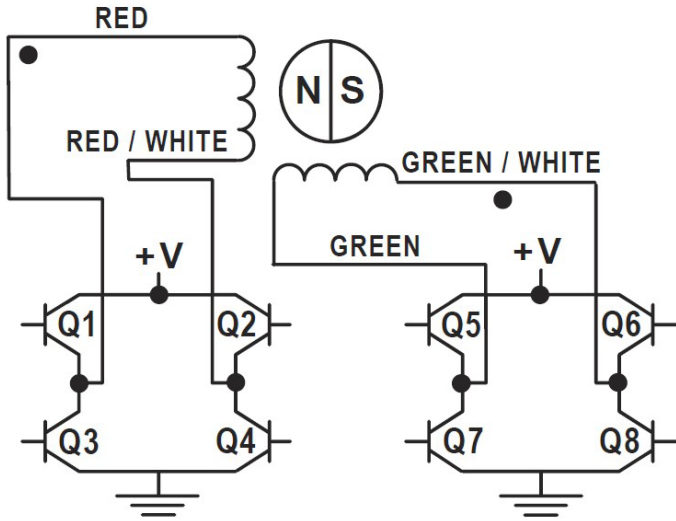

Hybrids: Stepping Sequence

EXTEND CW ↓	Bipolar	Q2-Q3	Q1-Q4	Q6-Q7	Q5-Q8	↑ RETRACT CCW
	Step					
	1	ON	OFF	ON	OFF	
	2	OFF	ON	ON	OFF	
	3	OFF	ON	OFF	ON	
	4	ON	OFF	OFF	ON	
	1	ON	OFF	ON	OFF	

Note: Half stepping is accomplished by inserting an off state between transitioning phases.

Integrated Connector for Hybrid Size 8

Offered alone or with a harness assembly, this connector is RoHS compliant and features a positive latch in order for high connection integrity. The connector is rated up to 2 amps and the mating connector will handle a range of wire gauges from 24 to 28. Ideal for those that want to plug in directly to pre-existing harnesses.

- Motor Connector:
JST part # S04B-ZESK-2D
- Mating Connector:
JST part # ZER-04V
Haydon Kerk Part # 56-2369-1 (12 in. Leads)
- Wire to Board Connector:
JST part # SZE-002T-P0.3

Pin #	Bipolar	Color
1	Phase 2 Start	G/W
2	Phase 2 Finish	Green
3	Phase 1 Finish	R/W
4	Phase 1 Start	Red

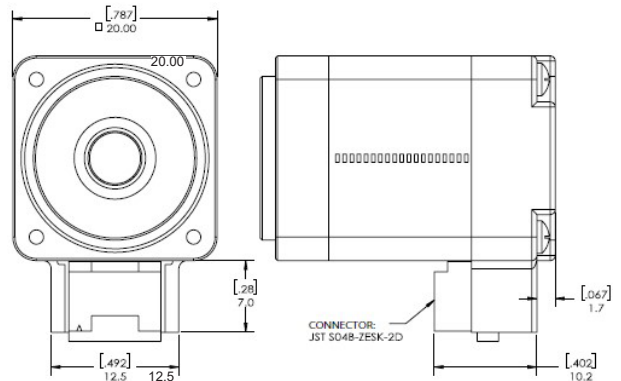

Encoders for Size 8 Hybrid Linear Actuators

All Haydon Hybrid Linear Actuators are available with specifically designed encoders for applications that require feedback. The compact optical incremental encoder design is available with two channel quadrature TTL squarewave outputs. An optional index is also available as a 3rd channel. The Size 8 Encoder provides resolutions for applications that require 250 and 300 counts per revolution. Encoders are available for all motor configurations – captive, non-captive and external linear.

Simplicity and low cost make Encoders ideal for both high and low volume motion control applications. The internal monolithic electronic module converts the real-time shaft angle, speed, and direction into TTL compatible outputs. The encoder module incorporates a lensed LED light source and monolithic photo-detector array with signal shaping electronics to produce the two channel bounceless TTL outputs.

21mm 21000 Series Size 8

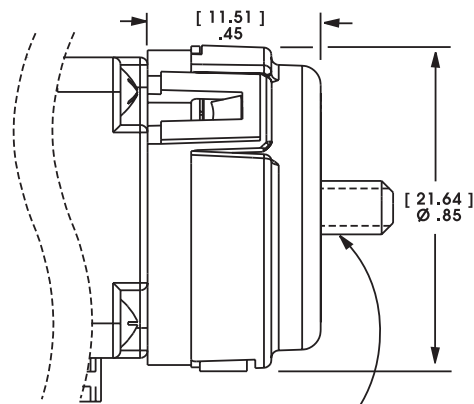

NOTE: Lead Screw extends beyond encoder on specific captive and non-captive motors.
External linear shaft extension is available upon request.

Single Ended Encoder - Pinout - Size 8	
Connector Pin #	Description
1	+5 VDC Power
2	Channel A
3	Ground
4	Channel B



Size 8 with Encoder

Electrical Specifications				
	Minimum	Typical	Maximum	Units
Input Voltage	4.5	5.0	5.5	VDC
Output Signals	4.5	5.0	5.5	VDC

2 channel quadrature TTL squarewave outputs.
Channel B leads A for a clockwise rotation of the rotor viewed from the encoder cover.
Tracks at speeds of 0 to 100,000 cycles/sec.
Optional index available as a 3rd channel (one pulse per revolution).

Operating Temperature		
Size 8	Minimum	Maximum
	- 10°C (14°F)	85°C (185°F)

Mechanical Specifications	
	Maximum
Acceleration	250,000 rad/sec ²
Vibration (5 Hz to 2 kHz)	20 g

Resolution			
4 Standard Cycles Per Revolution (CPR) or Pulses Per Revolution (PPR)			
Size 8	CPR	250	300
	PPR	1000	1200

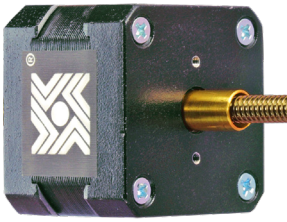

Encoder Ready Option Shown 34000 Series Size 17

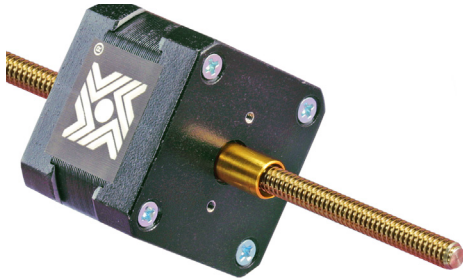

Extended Rotor Journal Shown 34000 Series Size 17



End of Stroke Proximity Sensor



TFE Coated Lead Screw

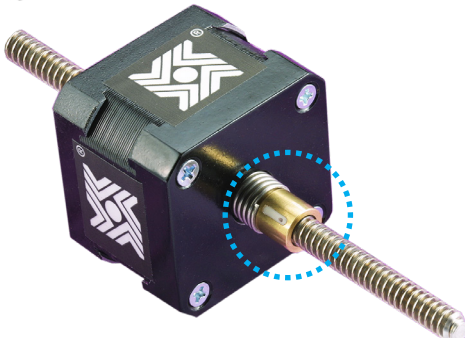

Integrated Anti-Backlash Nut

Encoder Ready Option for all Hybrid Sizes

Our Hybrid Linear Actuators can now be manufactured as an Encoder Ready Actuator. Encoder Ready Actuators can be used to install several popular hollow shaft encoders. Available with an extended rotor journal and a threaded rear housing. The motor uses a proprietary manufacturing process which incorporates engineering thermoplastics in the rotor drive nut and a stainless steel Acme Lead Screw that allows the motor to be much more efficient and durable than today's more commonly used V-thread bronze nut configurations.

Extended Rotor Journal for all Hybrid Sizes

Available with an extended rotor journal. The extended rotor journal can be used for encoder installation, manual adjustment, or flag installation for a positioning sensor.

Home Position Switch for Hybrids

A miniature electronic Home Position Switch capable of monitoring the home positions of linear actuators. The switch mounts on the rear sleeve of captive linear motors and allows the user to identify start, stop or home positions.

When ordering motors with the home position switch the part number should be preceded by an "S" prefix.

End of Stroke Proximity Sensor for all Hybrid Sizes

The Sensor incorporates a hall effect device, which is activated by a rare earth magnet embedded in the end of the internal screw. The compact profile of the sensor allows for installation in limited space applications. The sensor has a virtually unlimited cycle life. Special cabling and connectors can also be provided. When ordering motors with the proximity sensor, the part number should be preceded by a "P" prefix.

Black Ice® and Kerkote® TFE Coated Lead Screws*

TFE Coated Lead Screws for applications that require a *greaseless* screw and nut interface.

A dry (non-lubricated) TFE coated lead screw provides improved performance in both life and thrust as compared to a conventional stainless steel lead-screw. TFE can be applied to a wide variety of lead-screw pitches and is available for our brand captive, non-captive and external linear actuators. Not available for 0.00006-in (.0015 mm) and 0.000098-in (.0025 mm) resolutions.

*Certain conditions apply.

Integrated Anti-Backlash Nut for Hybrids*

Most sizes (except Size 34) of our captive and non-captive hybrid stepper motors can be equipped with an integral anti-backlash feature. There is a normal backlash between the lead screw and integral rotor nut.

Our actuators are designed for millions of cycles. However over time, additional backlash could increase and eventually double. Haydon Kerk Integrated Anti-Backlash Nut can eliminate all backlash. Designed specifically for our captive and non-captive hybrid motors, nuts use an opposing spring force to eliminate backlash between the screw and the nut interface. The nuts will self-compensate and accommodate any wear. Haydon Kerk Motion Solutions application engineers can help you select the appropriate preload for your application

*Except Size 34.