

UNIMOTION



MAINTENANCE - AND ASSEMBLY INSTRUCTIONS

CTV SERIES

Hypex d.o.o.
Alpska cesta 43, 4248 Lesce
Slovenia

Tel: +386 (0)4 531 8700 Fax: +386 (0)4 531 8740
www.unimotion.eu e-mail: sales@unimotion.eu

www.unimotion.eu

NOTES

TABLE OF CONTENTS

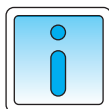

CONTENTS

PAGE

GENERAL INFORMATION						1.005.0
Used symbols	—	—	—	—	—	1.005.0
Tightening torques	—	—	—	—	—	1.005.0
General safety instructions	—	—	—	—	—	1.005.0
Safe operation	—	—	—	—	—	1.005.0
Modification of the linear unit	—	—	—	—	—	1.010.0
Labels and notices	—	—	—	—	—	1.010.0
Warranty	—	—	—	—	—	1.010.0
Handling the linear unit	—	—	—	—	—	1.015.0
Product description	—	—	—	—	—	1.025.0
Overview	—	—	—	—	—	1.030.0
MOUNTING						1.030.0
Fixing system - clamping fixtures	—	—	—	—	—	1.030.0
Fixing system - tapered / pin holes	—	—	—	—	—	1.030.0
Connection plates	—	—	—	—	—	1.035.0
Magnetic field sensor	—	—	—	—	—	1.040.0
Mechanical and inductive switch	—	—	—	—	—	1.045.0
Motor with coupling	—	—	—	—	—	1.050.0
Motor with motor side drive	—	—	—	—	—	1.055.0
MAINTENANCE						1.070.0
Lubrication of the carriage and ball nut	—	—	—	—	—	1.070.0
Lubricant	—	—	—	—	—	1.075.0
Lubricant quantities and intervals	—	—	—	—	—	1.075.0
Normal operating conditions	—	—	—	—	—	1.075.0
ASSEMBLIES						1.080.0
CTV 90 S	—	—	—	—	—	1.080.0
CTV 90 L	—	—	—	—	—	1.085.0
CTV 110 S	—	—	—	—	—	1.090.0
CTV 110 L	—	—	—	—	—	1.095.0
CTV 145 S	—	—	—	—	—	1.100.0
CTV 145 L	—	—	—	—	—	1.105.0
REPLACEMENT OF ASSEMBLIES						1.110.0
Replacing the floating bearing	—	—	—	—	—	1.110.0
Removing the spindle and ball nut from module	—	—	—	—	—	1.115.0
Replacing the fixed bearing	—	—	—	—	—	1.115.0
Replacing the spindle, ball nut and/or the carriage	—	—	—	—	—	1.120.0
Replacing the rails	—	—	—	—	—	1.125.0
Replacing the protection strip	—	—	—	—	—	1.130.0

GENERAL INFORMATION

USED SYMBOLS



Remark, note



Warning!



Danger!

Risk of coming into contact with power conducting parts! Cut off power supply!



Caution!

Keep Linear Unit clean!
Cover it, if necessary!



For more information see the catalogue



Do not use glue in current step



Use appropriate tools for the current step



Use a different tightening torque than in table on page 1.005.0

TIGHTENING TORQUES

Following tightening torques are recommended for screws of strength class 8.8

8.8	M2	M2,5	M3	M4	M5	M6	M8	M10	M12
M_{max} [Nm]	0.4	0.7	1.3	2.8	5.6	9.6	23	45	74



Screw



Tightening torque

Following tightening torques are recommended for screws of the self locking device

8.8	M2,5	M3	M4	M5	M6	M8
M_{max} [Nm]	1.2	2.1	4.9	9.7	17	41

GENERAL SAFETY INSTRUCTIONS

To ensure the right functionality of the CTV Linear Unit, it must be handled with care. It is not allowed to put any tools or any other items which can cause damage to the linear unit on the linear unit.

The linear Unit must be protected against any liquid that can cause damage to it.

The CTV Linear unit must be placed in a dry, clean environment. For information on conditions in which the linear module can operate, please contact us.

If the Linear Unit isn't in use, place it in a dry, clean environment and cover it to prevent any damage.

SAFE OPERATION

The linear unit must not be put into service until the final machinery into which it is installed has been declared in conformity with the provisions of the Machinery Directive, where appropriate.

Each operation of the Linear Unit that is not in compliance with its intended use can lead to the product being damaged, accidents and at the same time stoppages in production. To ensure a safe operation please refer to this Instruction Manual and the operating manual of other machinery where the Linear Unit is to be incorporated.

The linear unit satisfies the requirements of EC Machinery Directive 2006/42/EC according to European or national standards of safety of machinery:

- EN ISO12100-1
- EN ISO 12100-2



Checking the linear unit

In accordance with EU Health and Safety Directive 89/655/EEC article 4a, the operating company must subject the unit to thorough checking prior to putting it into operation, after carrying out repairs, and after malfunctions have occurred.



Requirements for personnel

The Linear Units may only be installed, operated, maintained, repaired or dismantled by appropriately qualified personnel in accordance with specifications used in this manual use. All qualified personnel must have read and understood this Instructions Manual.

MODIFICATION OF THE LINEAR UNIT

The linear unit must not be modified without our written consent. Any such unauthorised modification will void our liability in respect of the unit. The operating company may only carry out the maintenance and repair work detailed in this Instruction Manual.

LABELS AND NOTICES

All notices and labels attached to the linear unit must be fully visible and must not be removed. They must ensure compliance with all the instructions contained on them. Damaged or illegible notices and labels must be replaced.

WARRANTY

The warranty conditions are laid down in the terms and conditions of delivery and payment issued at time of the order. Warranty cover will be annulled if:

- the Unit is not operated in accordance with the stipulated regulation use;
- the instructions set out in this Instruction Manual are not followed;
- the Unit is modified without the consent of the manufacturers;
- the screws sealed by locking varnish are unlocked.

The manufacturer's warranty in respect of maintenance and repair work applies only if original replacement parts are used.

HANDLING THE LINEAR UNIT

The Linear units are carefully packed in a HARD WOODEN BOX for a safe transportation.

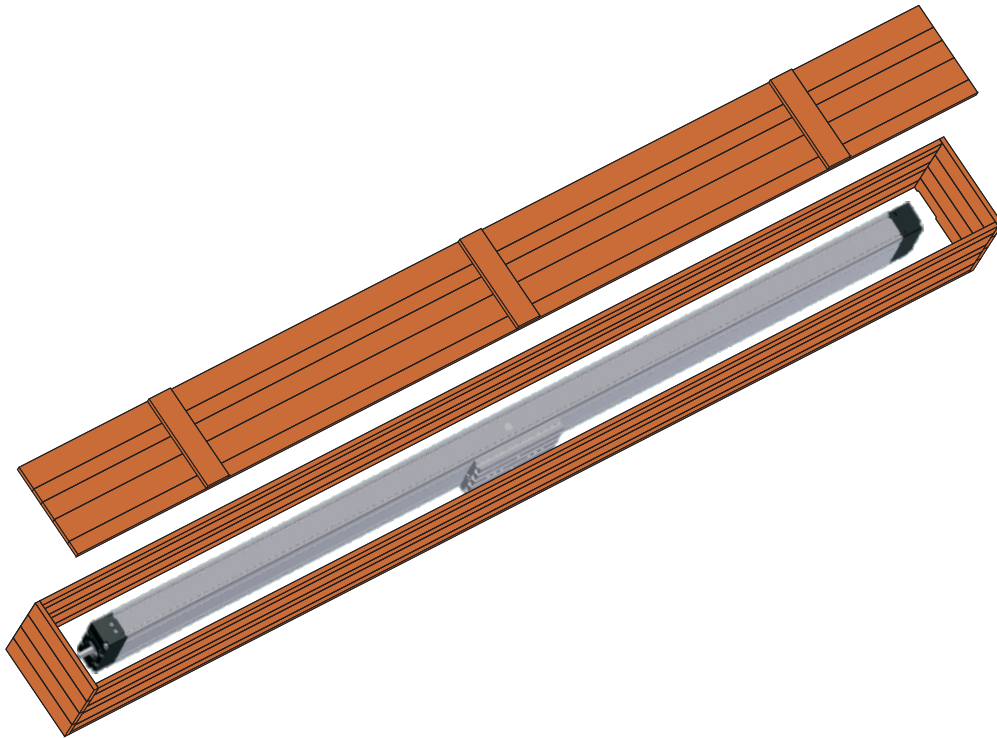

To take the Linear Unit out of the box, please consider the following handling instructions:

- Never lift the Linear Unit by the END BLOCKS - see PICTURE A
- Never grab for the CARRIAGE or the CARRIAGE WITH CONNECTION PLATE
- Never grab for the PROFILE COVER (Aluminum cover)

To take the Linear Unit out of the box, a suitable lifting tool is needed. Always lift and carry the Linear Unit by the main profile.

The Linear Unit must be supported all the time during the handling until it is fixed - mounted on the place, where it is meant to be. For correct handling please refer to page number 1.020.0

PICTURE A is showing, that handling with the Linear Unit in this position is wrong, because the profile, guides and other components might get deflected or damaged.

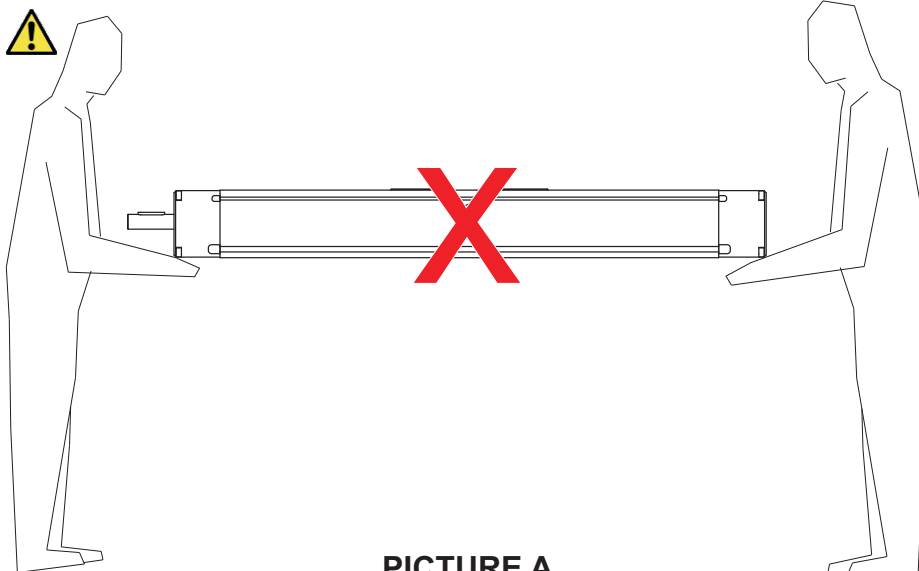

 Carrying the Linear Unit holding the END BLOCKS isn't allowed, it must be carried holding the PROFILE of the Linear Unit.

PICTURE A

PICTURE B is showing correct handling of the Linear Unit. The profile is more stiff in vertical alignment which prevents the deflection.

PICTURE B

$L > 2000\text{mm}$

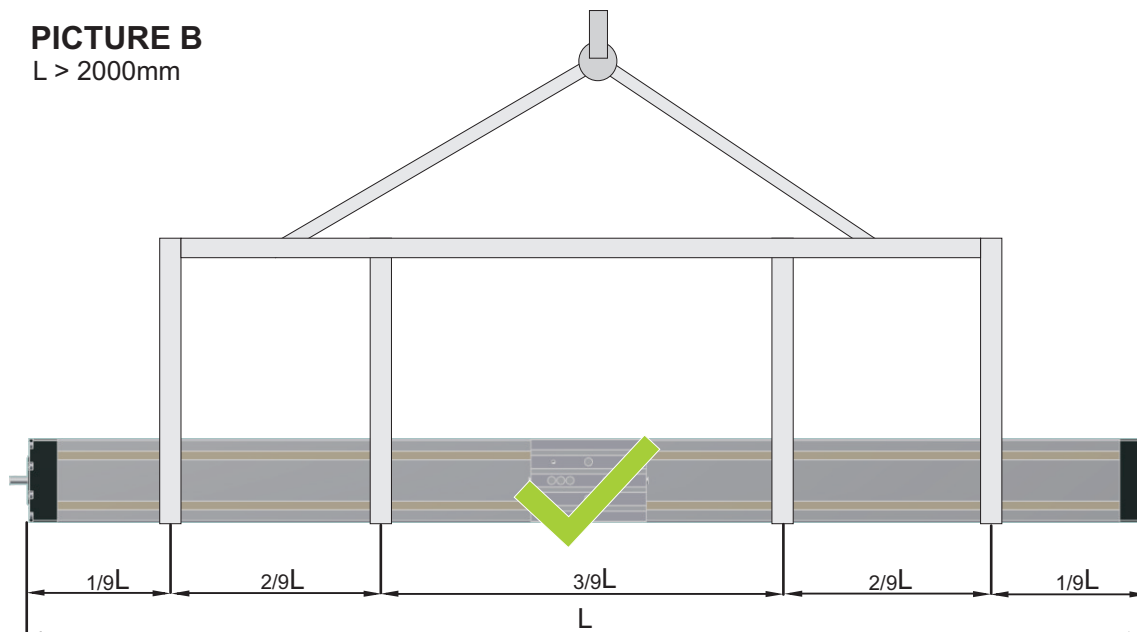

PICTURE C is showing correct handling of the Linear Unit.

PICTURE C

$L < 2000\text{mm}$

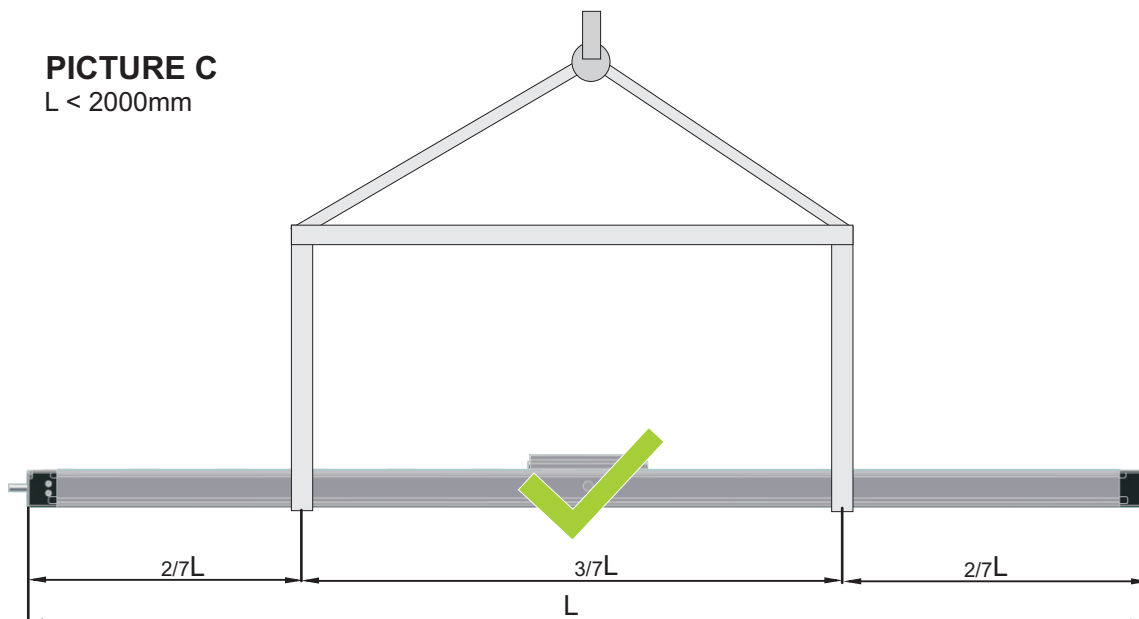

WARNING

Calculate the weight of the linear unit in order to choose the suitable lifting tool for the transportation of the Linear Unit.

Please refer to the catalogue UNIMOTION - LINEAR UNITS for weight calculations.

Linear Unit needs to be stored in dry place and protected against corrosion. Make sure that there is no danger for the Linear Unit to get damaged.

PRODUCT DESCRIPTION

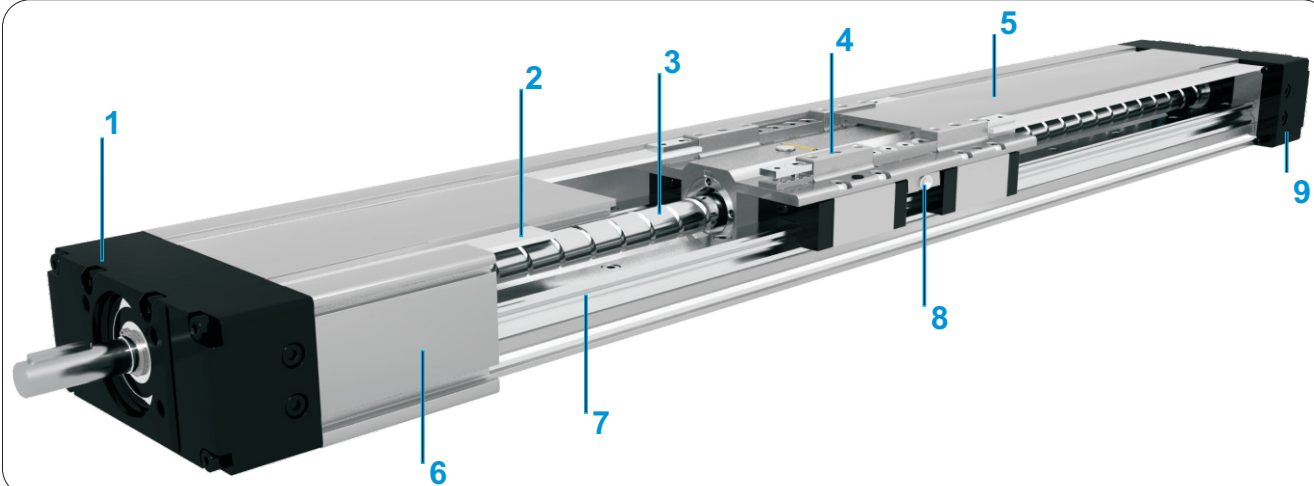

- 1 - Drive block with floating bearing
- 2 - Gap-type seal of antistatic PU strip (recirculating)
- 3 - Ball screw tolerance ISO7 (ISO5 available on request)
- 4 - Carriage; with built in Magnets
- 5 - Aluminum cover
- 6 - Aluminium profile-Hard anodized
- 7 - Two integrated Linear Ball Guideways
- 8 - Central lubrication port; both sides
- 9 - End block with fixed bearing





OVERVIEW

Identification label and additional or replacement parts of the Linear Unit

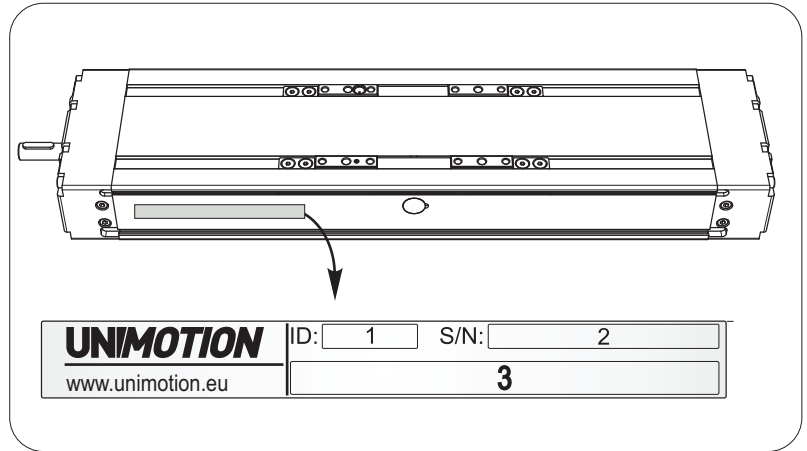
- 1 - ID number
- 2 - Serial number
- 3 - Type of Linear Unit (ordering code)



 In the case of ordering additional or replacement parts for the Linear Unit all the data from the identification label must be given.

 The label must be fully visible (in particular details of the serial number) and must ensure compliance with all the instructions contained on it. Damaged or illegible labels must be replaced.

MOUNTING

Fixing system - clamping fixtures



 **the Linear Unit must be mounted by the aluminium profile with evenly distributed clamping fixtures along the entire length!**

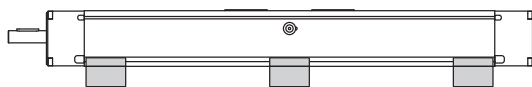

 **Number of clamping fixtures:**
Please refer to our catalogue UNIMOTION Linear Units on page 7.000.0

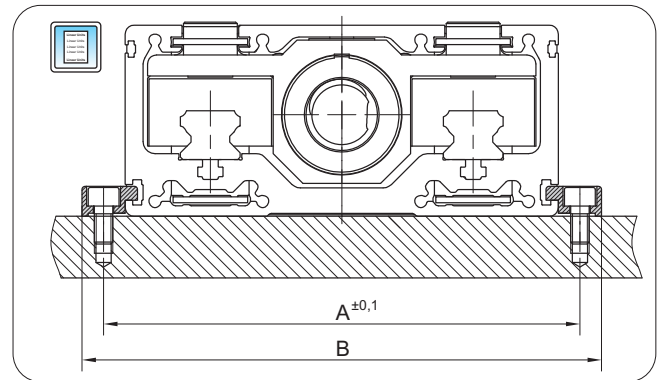



The modules are mounted by using fixtures which are placed in the slot on the side of the profile.

CTV	A [mm]	B [mm]
90	102	112
110	126	140
145	161	175

Fixing system - TAP/PIN Holes

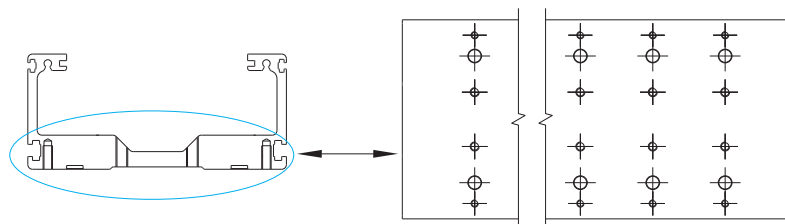
Fixing the Linear Unit can also be done at the bottom of profile using TAP / PIN holes, which can be made on request.



 TAP/PIN holes can only be made based on the manufacturer's drawing of the position and depth of the TAP/PIN holes. For the drawings showing the position and depth of TAP/PIN holes, please contact us.

MOUNTING

Connection plates



The connection plate contains two lubrication nipples DIN 3405D for the carriage and the ball nut. Before mounting the connection plate on the Linear Unit it must be fully filled with grease. The connection plate can be removed and replaced at any time.

Short Carriage version

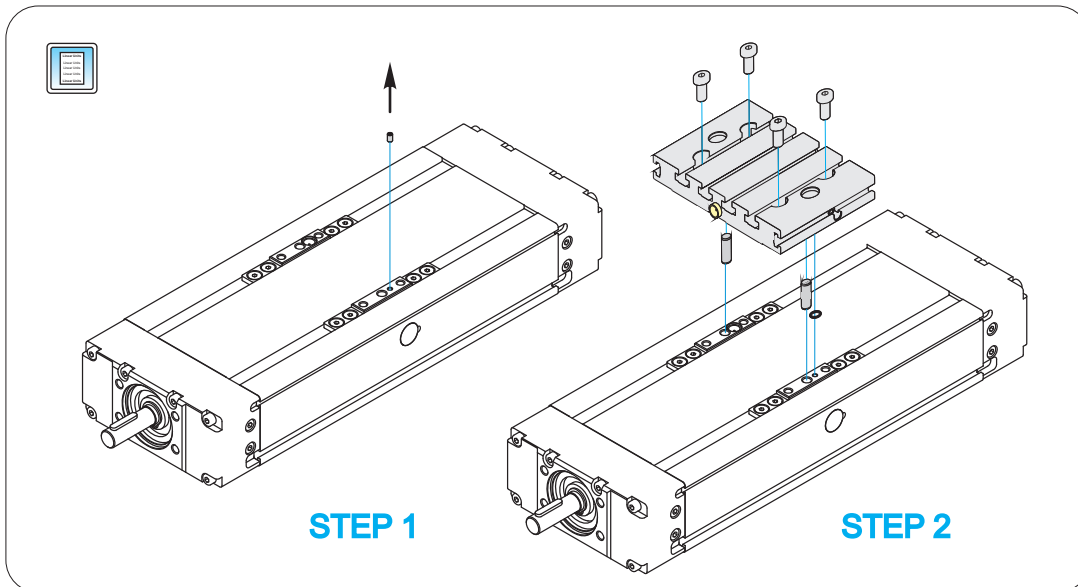

Long Carriage version

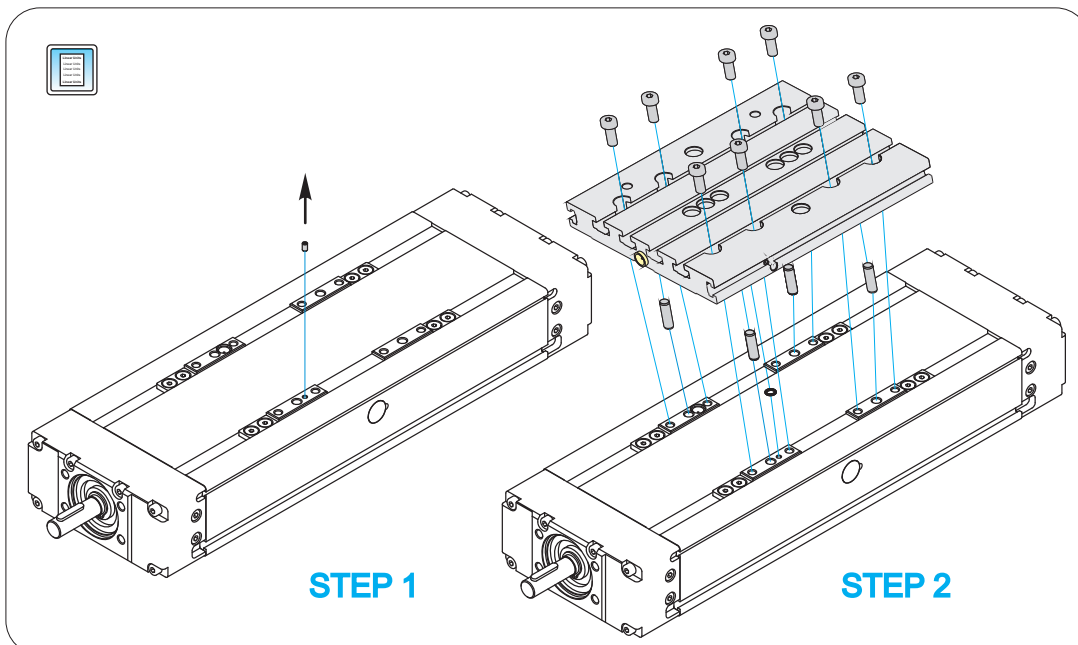

STEP 1: The lubrication port is closed by a screw DIN 913. Remove the screw (DIN 913), which is placed on the carriage of the Linear Unit.

STEP 2: Insert cylindrical pins (DIN EN 28734 A) into the connection plate.



Place the O-RING seal on the location where the connection plate has its recess for the O-ring seal. Before placing the O-RING seal on to the location, it must be first lubricated with grease.

Assemble the connection plate with linear unit

Insert the screws (DIN 912) for fixing the connection plate onto the carriage of the Linear Unit and tighten them.



For the tightening torques for the screws please refer to page number 1.005.0

MOUNTING

Magnetic field sensor - REED SWITCH with a HOM bracket

STEP 1: The magnetic field sensor must be first mounted on the HOM bracket. After mounting the switch on the HOM bracket place the HOM bracket with the switch in to the slot, designed for the HOM bracket. Mounting the HOM bracket with the switch can done on the left or right side of the profile of the Linear Unit.

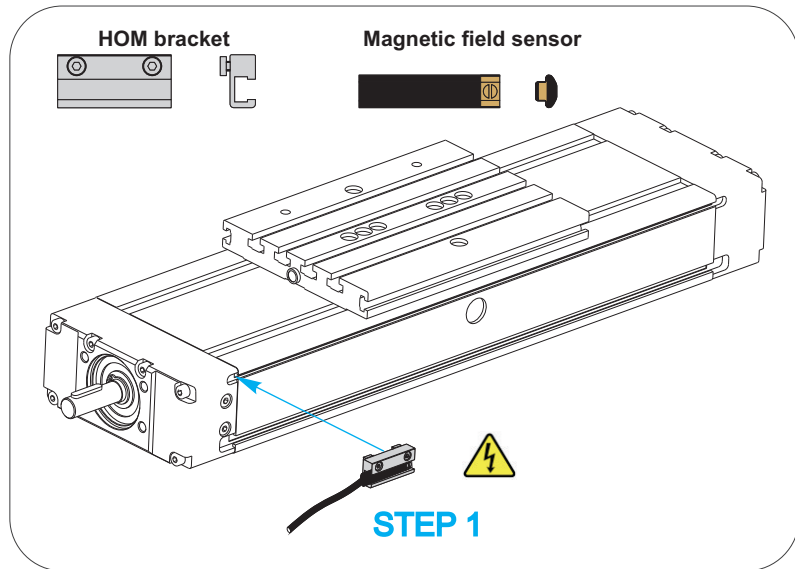

STEP 2: After the HOM bracket has been inserted in to the slot, position the HOM bracket with the switch in the desired location.

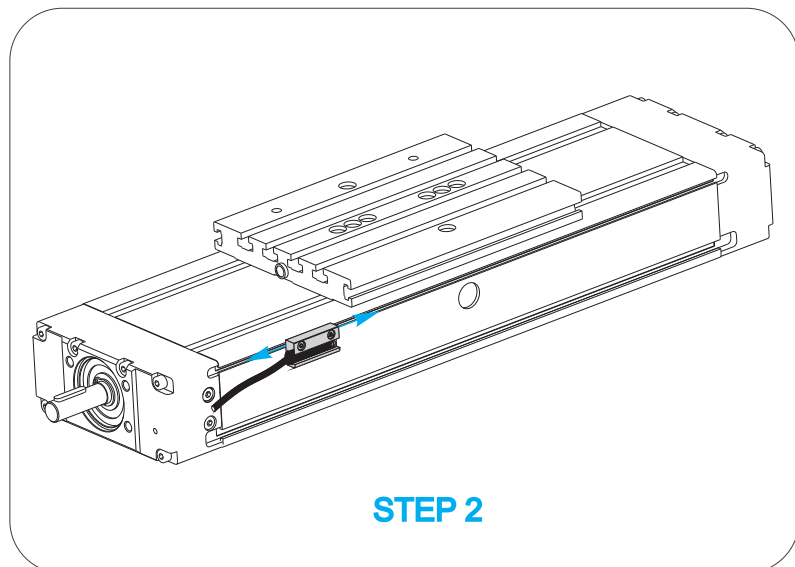

STEP 3: When the HOM bracket with the switch is in the desired location, tighten the HOM bracket screws to fix it.

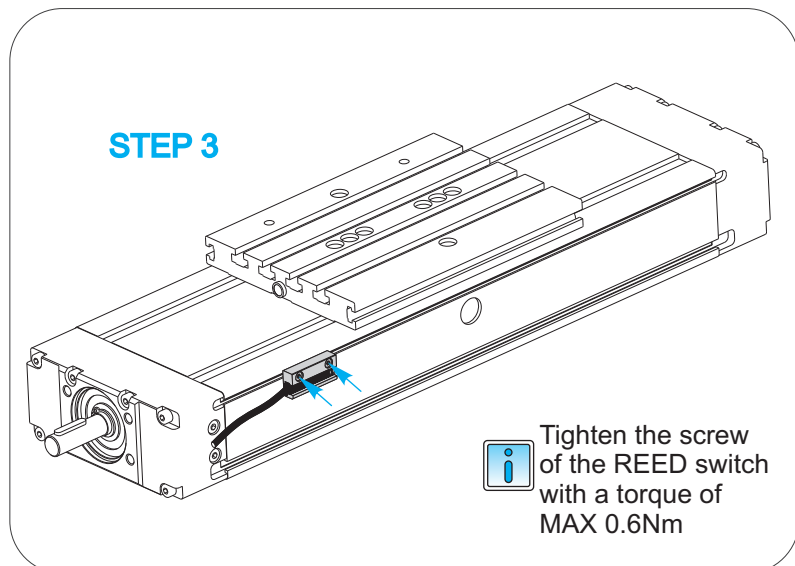

 For tightening torques for the screws please refer to page number 1.005.0

MOUNTING

Mechanical and Inductive switch with the mounting bracket

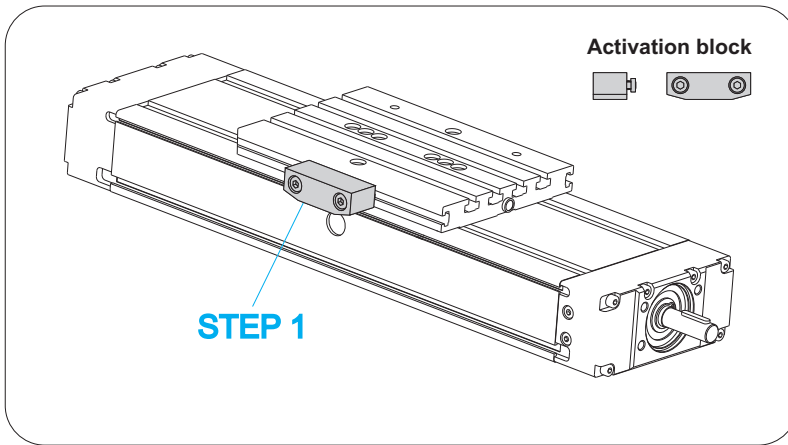

STEP 1: Mount the activation block on the connection plate in the desired location. The activation block can be mounted in any location along the length of the connection plate on the left or right side. After the activation block is in place in the desired location, tighten the screws.

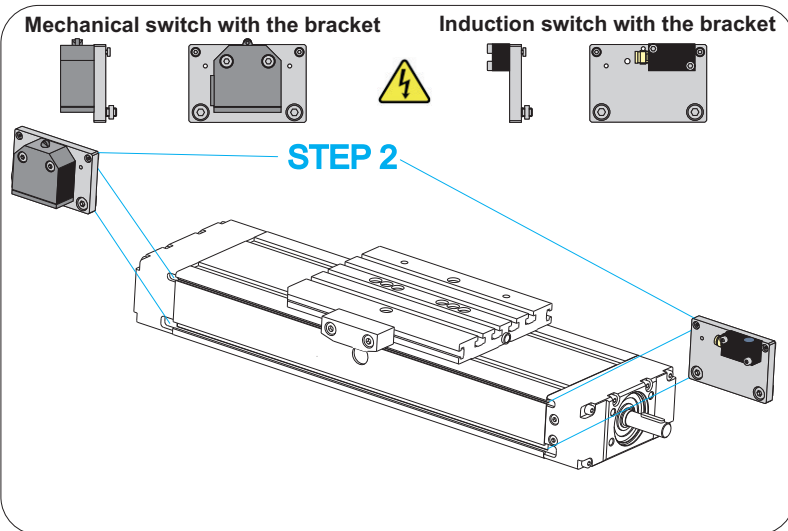

STEP 2: Place either the mechanical switch or the inductive switch with brackets in the slots and position them in the desired location. The mechanical or inductive switch with brackets can be placed in the slots either on the left or right side of the profile of the Linear Unit.

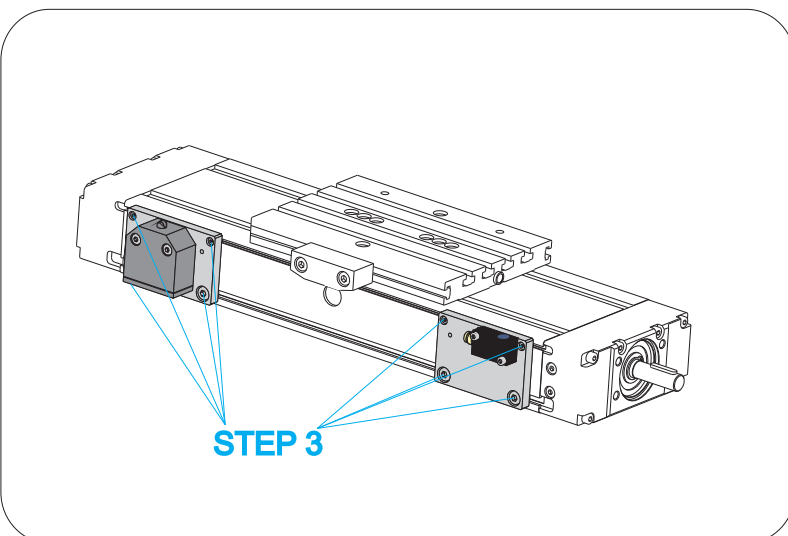

STEP 3: After the mechanical or inductive switch with brackets is placed in the desired place in slots, tighten the screws of the bracket.



For tightening torques for the screws please refer to page number 1.005.0

MOUNTING

Motor with coupling

If motor adapter has inner through hole of the same size its entire length.

STEP 1: Attach one half of the coupling to the shaft of the linear unit and other to the shaft of the motor.

Insert coupling spider into one half of the coupling.

STEP 2: Attach motor adapter to the linear unit.

STEP 3: Attach motor to the motor adapter.

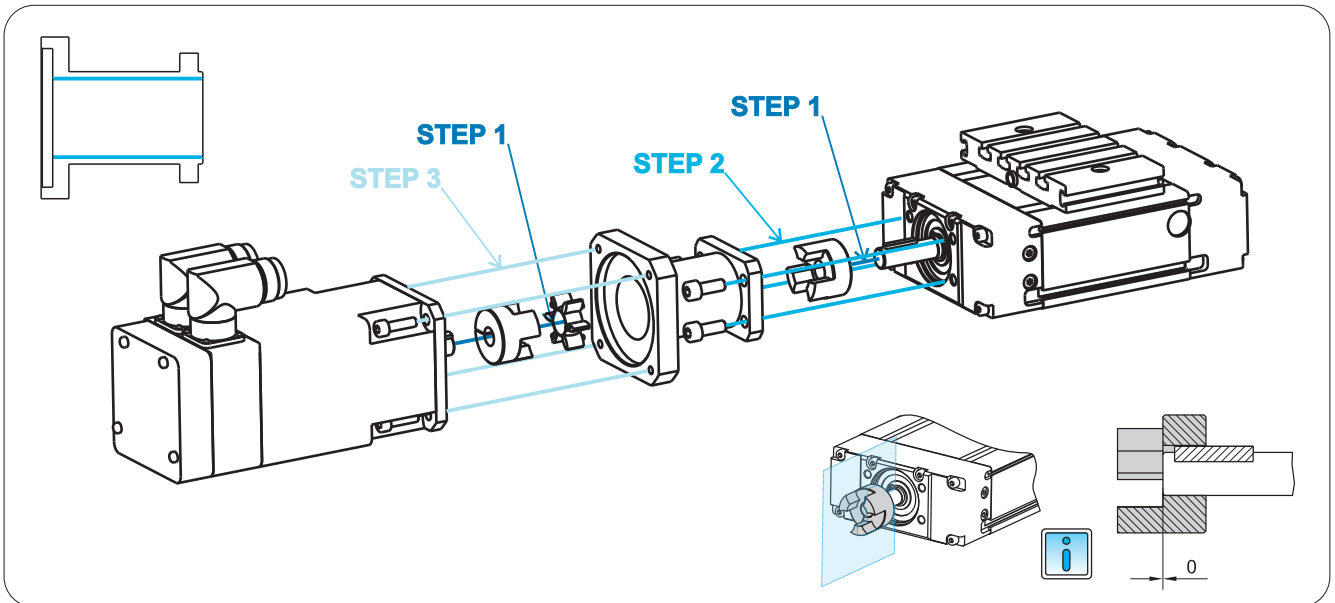

If motor adapter has inner through hole with the narrowing at one end.

STEP 1: Attach motor adapter to the side on which the through hole is narrower.

STEP 2: Attach complete coupling to the axle on the wider side of the hole.

STEP 3: Assemble two parts together and tighten the remaining screw on the coupling through appropriate hole in motor adapter.

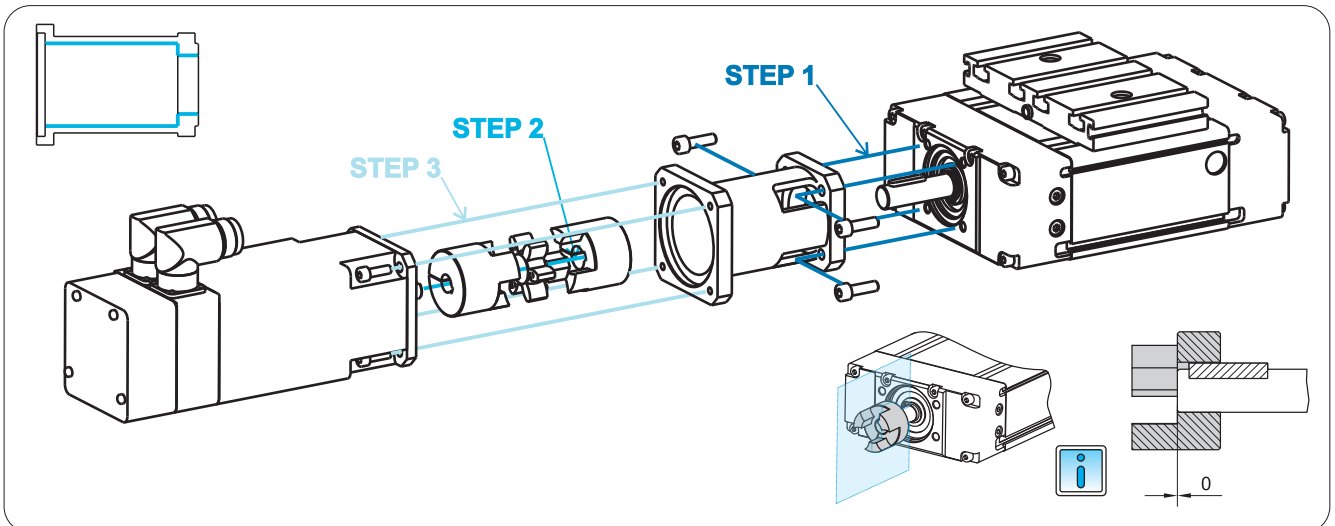

Tighten the screws on the coupling halves with coupling tightening torque.

The maximum torque and maximum speed of the motor must never exceed the limits of the Linear Unit!

For tightening torques for the screws please refer to page number 1.005.0

MOUNTING

Motor with motor side drive - MSD



The maximum speed and the maximum torque of the motor must not exceed the limits of the Linear Unit CTV. For the values of speed and torque, please see our catalogue UNIMOTION Linear Units.

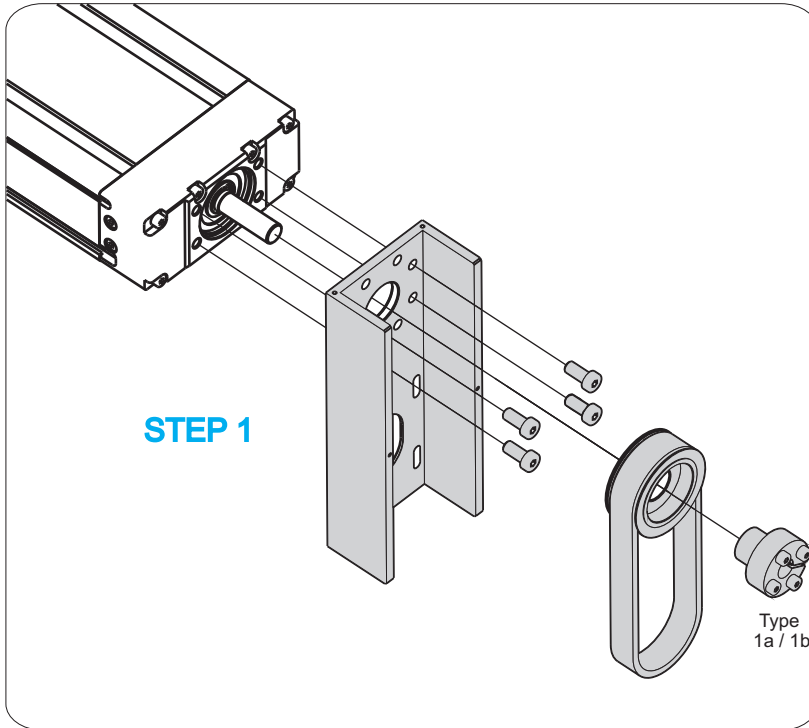

STEP 1

STEP 1: The housing of the motor side drive - MSD must be mounted and screwed on the drive block of the linear unit. The housing can be mounted in any way - UP, DOWN, RIGHT or LEFT.



The motor side drive - MSD can be only used on the Linear Unit with the ball screw journal without a keyway - ball screw journal type 0 - more info see our catalogue UNIMOTION Linear Units on page 6.005.0

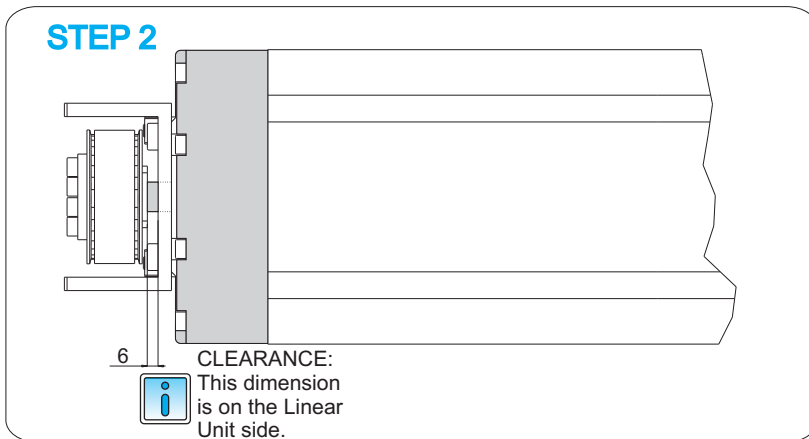

STEP 2

6 CLEARANCE:
This dimension is on the Linear Unit side.

STEP 2: After the housing has been mounted on the Linear Unit, the belt sprocket with a toothed belt and a self locking device must be fitted on the ball screw journal of the Linear Unit. Adjust the clearance as shown in the picture.

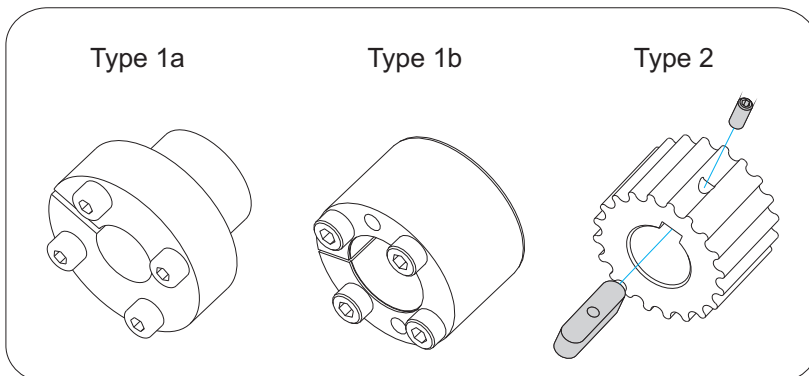

Type 1a

Type 1b

Type 2



Types of journal tensioning units.



For tightening torques for the screws please refer to page number 1.005.0

MOUNTING

Motor with motor side drive - MSD

RATIO $i=1$

STEP 3a: Mount the motor onto the housing and tension lightly the tightening screws of the motor.
When the motor is mounted, mount the belt sprocket with the tension unit onto the motor journal.
Adjust the clearance as shown on the picture.
Tension the tension unit. Tension the motor with the belt with the pretensioning force F and tighten the motor down on the housing. The pretensioning force F depends of the size of the Linear Unit and motor.

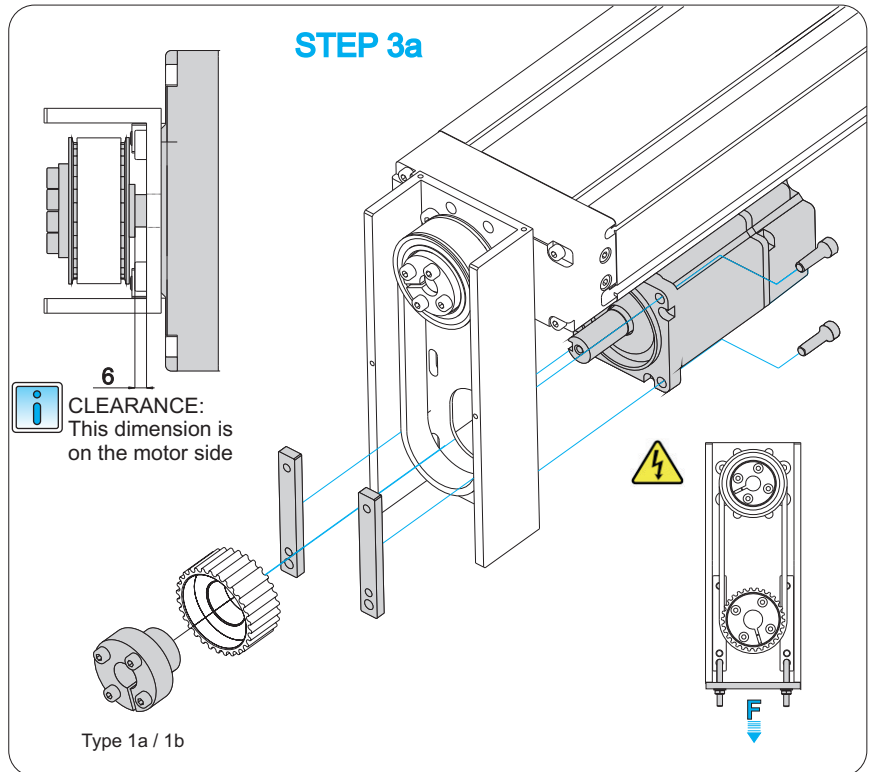

RATIO $i=1,5$ or 2

STEP 3b: Mount the motor onto the housing and lightly tension the tightening screws of the motor.
When the motor is mounted, mount the belt sprocket with the tension unit onto the motor journal.
Adjust the clearance as shown in the picture.
Tension the tension unit.
Tension the motor with the belt with the pretensioning force F and tighten the motor down on the housing.
The pretensioning force F depends of the size of the Linear Unit and motor.

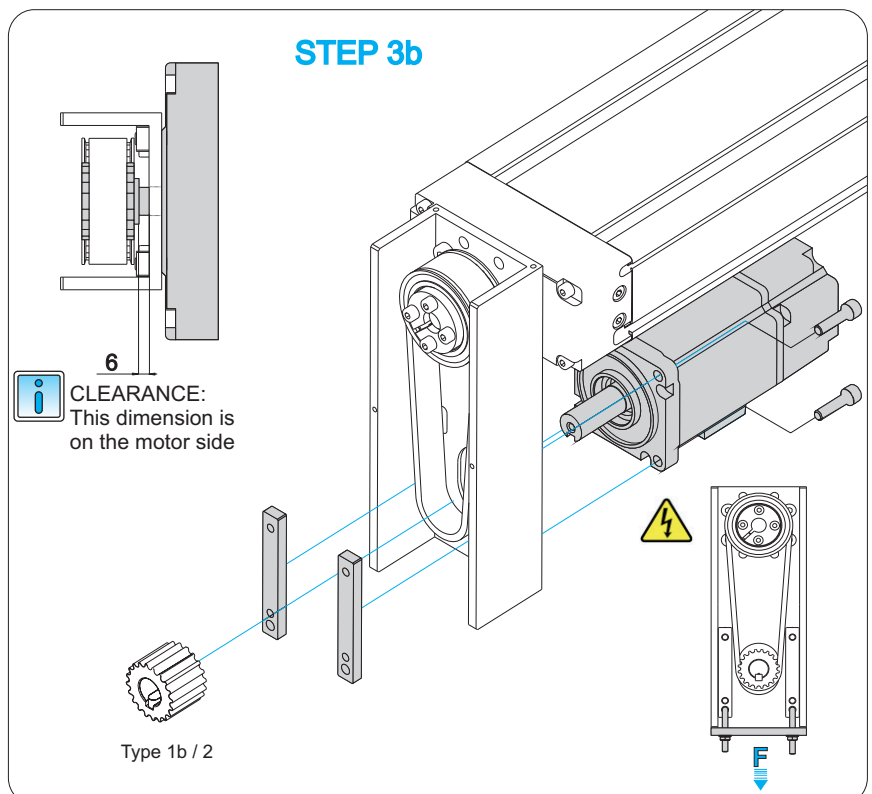

 For tightening torques for the screws please refer to page number 1.005.0

MOUNTING

Motor with motor side drive - MSD

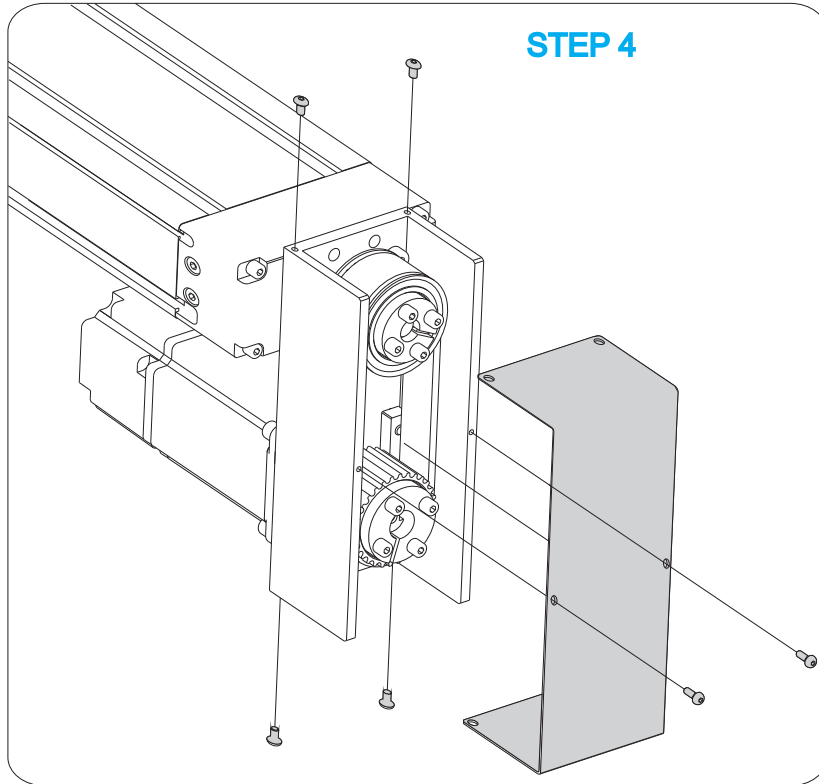

STEP 4: Mount the protection cover on the housing of the motor side drive - MSD. Tighten the screws.

-  Before the initial start-up, check if everything is OK:
- electrical wiring
 - mounted elements
 - tightened screws
 - correct tensioning of the belt

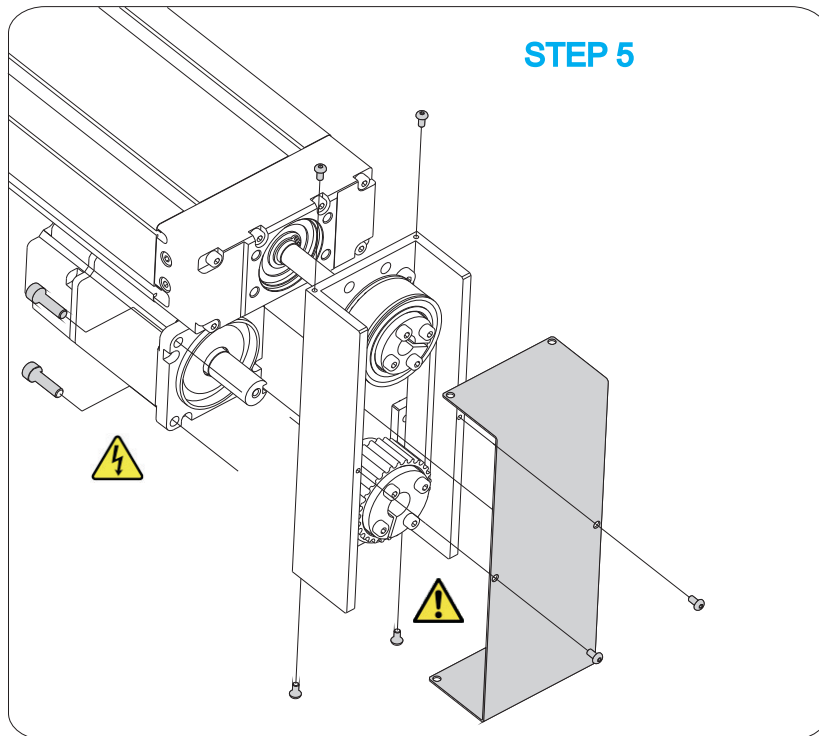

STEP 5: To dismount the motor side drive - MSD, take precautions, such as turning of the power supply, prevent the carriage from dropping, if it is in the vertical position. To dismount the MSD properly, look at the mounting procedure.

-  Take care when loosening the mounting screws on the motor, because the toothed belt is pretensioned.

 For tightening torques for the screws please refer to page number 1.005.0

MAINTENANCE



For each Linear Unit the basic lubrication is done in the factory before shipment. All bearings of the ball screw have been lubricated for life and do not require any additional lubrication under normal operating conditions.

Lubrication of the corrosion resistant protection strip

Corrosion resistant protection strip must be lubricated at normal lubrication intervals (page 1.075.00) or as needed.

Apply thin film of **Turmofluid ED 13** oil to the surface of the protection strip and continue using linear unit.

Lubrication of the carriage and the ball nut

The lubrication ports for the Long and Short Carriage version are placed on both sides of the profile as shown in the picture on the left.

CTV	C [mm]
90 S	24
110 S	39
145 S	46

For access to the lubrication nipples (DIN 3405 D) inside, the carriage must be moved to the middle position, i.e. L/2.

The lubrication ports have a cover, which must be removed in case of lubrication. The lubrication ports are central, which means you can lubricate the ball nut and the carriage through one lubrication port - PIC1 .

The lubrication port on the top of the carriage has a lubrication nipple (DIN 3405 D) - PIC2 .

The other lubrication port is closed with a screw DIN 913 which can be removed - PIC2 . For more details look at the page 1.005.0

It is sufficient to lubricate the carriage and the ball nut through one of the two lubrication ports

Linear Unit with connection plate:

The connection plate has a lubrication nipple (DIN 3405 D) on each side.

It is sufficient to lubricate the carriage and the ball nut through one of the two lubrication nipples-PIC3

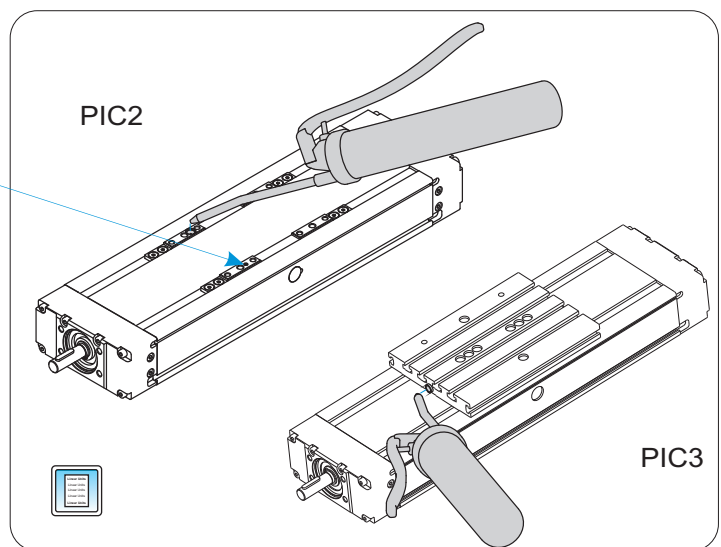
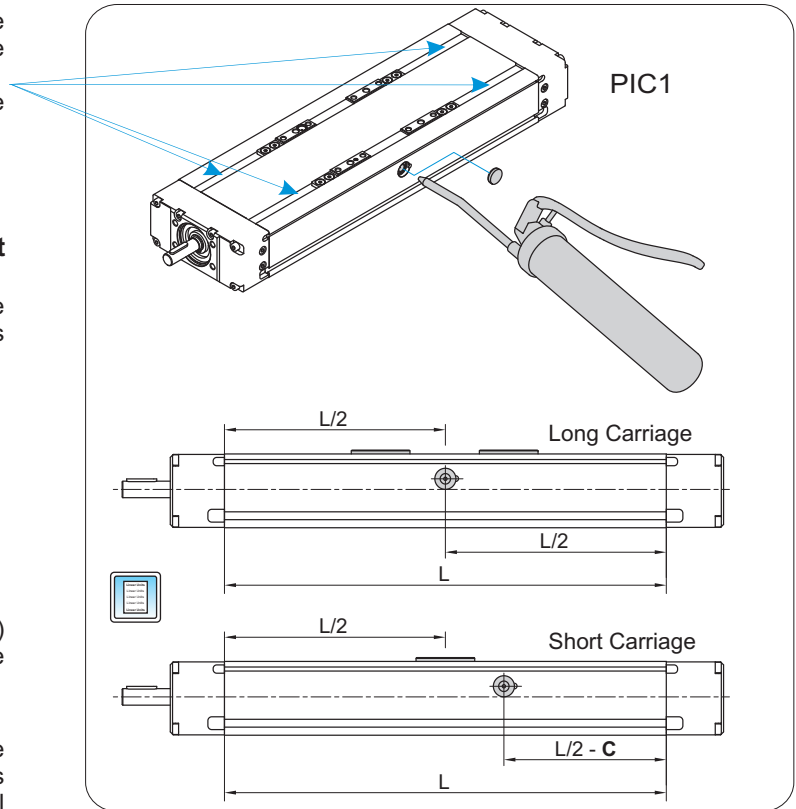

MAINTENANCE

Lubricant

Recommended grease for the lubrication

Lubcon TURMOGREASE LC 802 EP



For lubrication and re-lubrication of the linear units a grease lubricant must only be used! Do not use grease which contains any solid parts!

Lubricant quantities and intervals

	Ball Nut type	Ball screw [d × l]	Travel path [km]	Grease - relubrication quantity					
				LV short carriage			LV long carriage		
				Ball nut [cm ³]	Carriage [cm ³]	2nd Carriage [cm ³]	Ball nut [cm ³]	Carriage [cm ³]	2nd Carriage [cm ³]
CTV 90	RSY	12 × 5	250	0.4	0.3	0.3	0.4	0.6	0.6
		12 × 10	500	0.7	0.3	0.3	0.7	0.6	0.6
CTV 110	RSY	16 × 5	250	1.4	0.8	0.8	1.4	1.6	1.6
		16 × 10	500	1.8	0.8	0.8	1.8	1.6	1.6
		16 × 16	800	2	0.8	0.8	2	1.6	1.6
CTV 145	RSY	20 × 5	250	2.2	1.4	1.4	2.2	2.4	2.4
		20 × 10	500	4.4	1.4	1.4	4.4	2.4	2.4
		20 × 20	1000	4.8	1.4	1.4	4.8	2.4	2.4



The lubrication ports for Long and Short Carriage version are placed on both sides of the profile. The lubrication ports are central ports which means you can lubricate the ball nut and the carriage through one lubrication port.

The stated lubrication intervals in the table above are sufficient for normal operating conditions. If you have special operating systems please contact us.

The lubrication intervals are every 500 operating hours or after the specified travel path stated in the table above. It depends on which value is reached first.



For Linear Units with two carriages apply the quantity for the 1st Carriage and for the 2nd Carriage.

Normal operating conditions

Temperature: 10 °C - 30 °C

Travel speed: ≤ 1 m/s

Ball screw speed (RPM): 2500 1/min

Stroke: CTV 90 > 40 mm
CTV 110 > 50 mm
CTV 145 > 60 mm

Load: ≤ 0.2 C

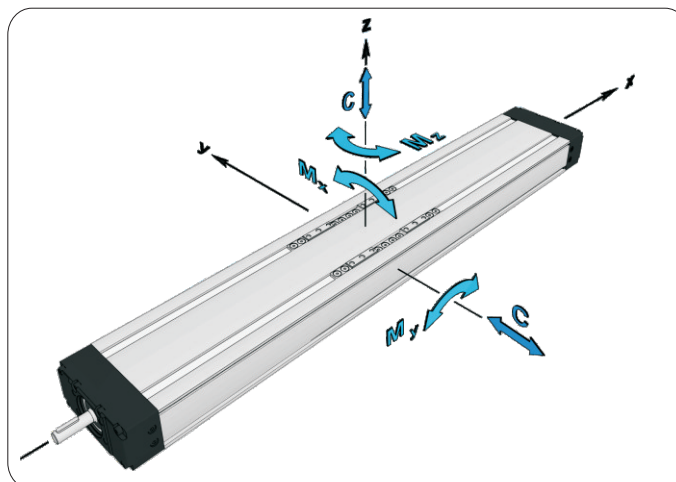

ASSEMBLY CTV 90 S

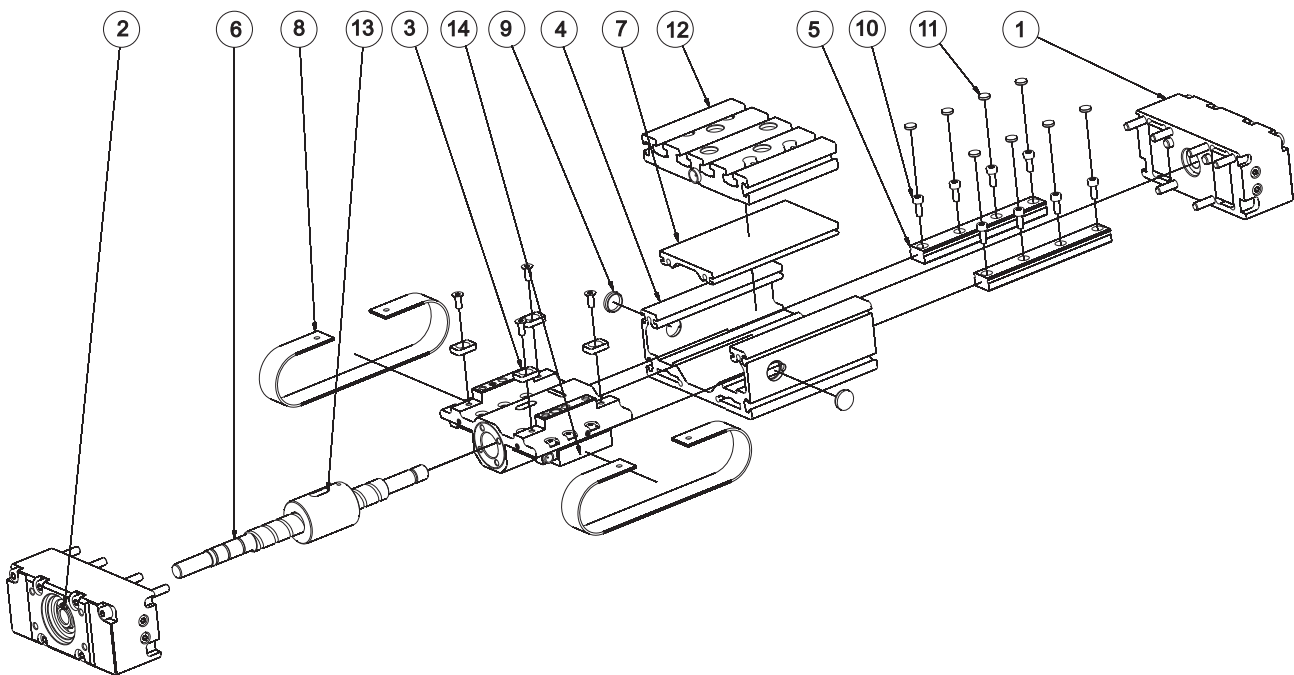

ITEM	QTY	PART NAME	LENGTH / QTY	ID
1	1	BACK BLOCK CTV 90		46712
2	1	FRONT BLOCK CTV 90		46711
3	1	CARRIAGE CTV 90 S		62397
4	1	PROFILE CTV 90	STROKE + 85	46622
5	2	RAIL GUIDE MR 12 - M	STROKE + 83	8207
6	1	BALL SCREW CTV 90	STROKE + 168	
		12 x 5 ISO7 - STANDARD, ISO5 - ON REQUEST		46903
		12 x 10 ISO7 - STANDARD, ISO5 - ON REQUEST		47334
7	1	PROFILE COVER CTV 90	STROKE + 85	46623
8	2	PROTECTION STRIP ANTISTATIC PU CTV 90	2 x STROKE + 230	46725
	2	PROTECTION STRIP CORROSION RESISTANT CTV 90	2 x STROKE + 230	51807
9	2	COVER FOR BGR 25		-
10		ALLEN SCREW M3 x 8 DIN 912	(RAIL LENGTH/25+0,68)x2	52937
11		COVER FOR MR 12 - M	(RAIL LENGTH/25+0,68)x2	-
12	1	CONNECTION PLATE CTV 90 S		
		CONNECTION PLATE CTV 90 S KPL		46906
13	1	BALL NUT RSY		
		12 x 5		46908
		12 x 10		46909
14	2	CARRIAGE BLOCK MINI MR12 MNSS VS-N		8208

ASSEMBLY CTV 90 L

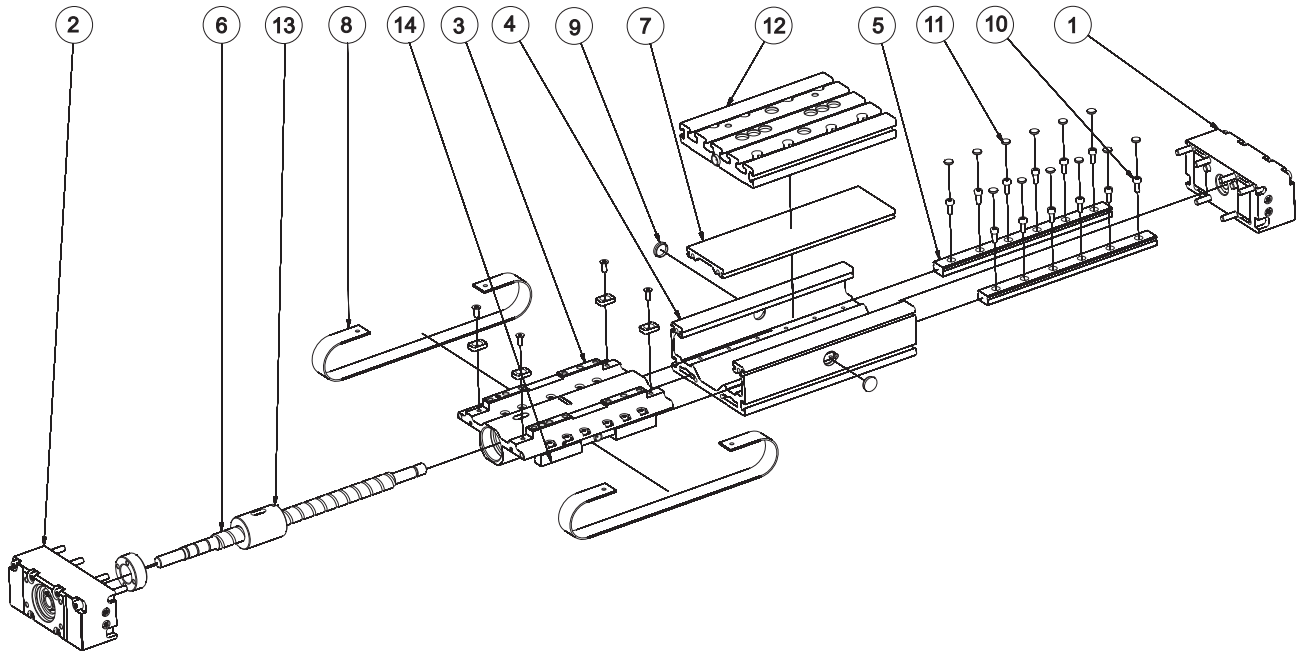

ITEM	QTY	PART NAME	LENGTH / QTY	ID
1	1	BACK BLOCK CTV 90		46712
2	1	FRONT BLOCK CTV 90		46711
3	1	CARRIAGE CTV 90 L		62388
4	1	PROFILE CTV 90	STROKE + 150	46622
5	2	RAIL GUIDE MR 12 - M	STROKE + 148	8207
6	1	BALL SCREW CTV 90	STROKE + 233	
		12 x 5 ISO7 - STANDARD, ISO5 - ON REQUEST		46903
		12 x 10 ISO7 - STANDARD, ISO5 - ON REQUEST		47334
7	1	PROFILE COVER CTV 90	STROKE + 150	46623
8	2	PROTECTION STRIP ANTISTATIC PU CTV 90	2 x STROKE + 295	46725
	2	PROTECTION STRIP CORROSION RESISTANT CTV 90	2 x STROKE + 295	51807
9	2	COVER FOR BGR 25		-
10		ALLEN SCREW M3 x 8 DIN 912	(RAIL LENGTH/25+0,08)x2	52937
11		COVER FOR MR 12 - M	(RAIL LENGTH/25+0,08)x2	-
12	1	CONNECTION PLATE CTV 90 L		
		CONNECTION PLATE CTV 90 L KPL		46907
13	1	BALL NUT RSY		
		12 x 5		46908
		12 x 10		46909
14	2	CARRIAGE BLOCK MINI MR12 MNSS VS-N		8208

ASSEMBLY CTV 110 S

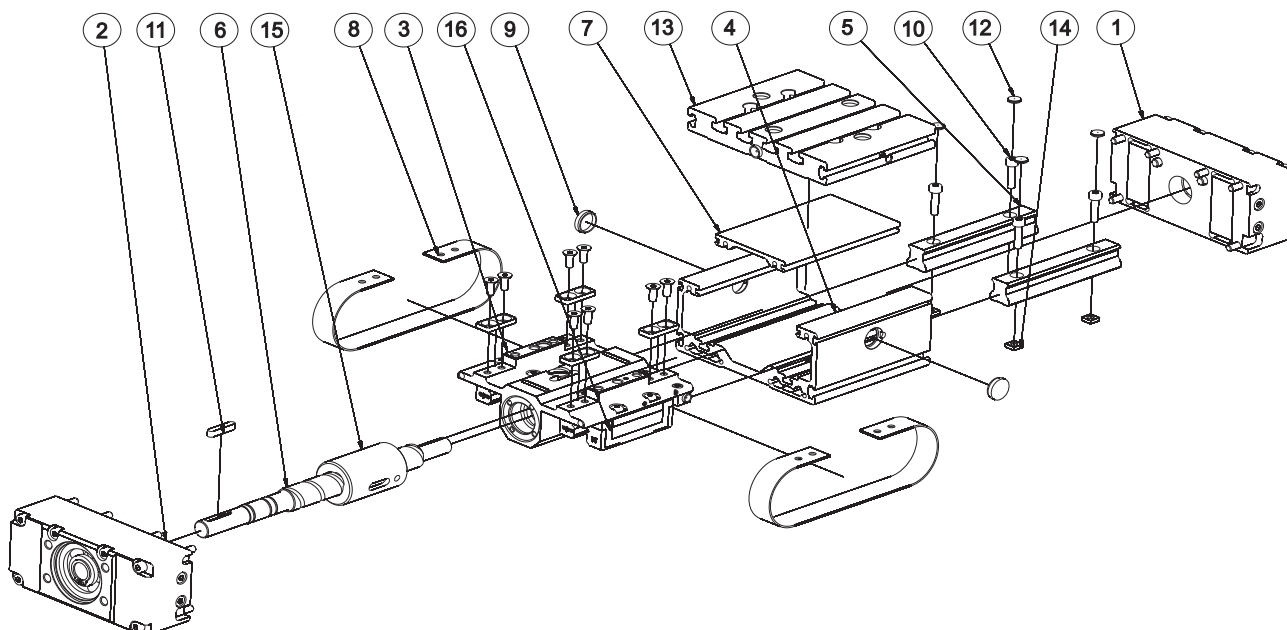

ITEM	QTY	PART NAME	LENGTH / QTY	ID
1	1	BACK BLOCK CTV 110		40492
2	1	FRONT BLOCK CTV 110		40489
3	1	CARRIAGE CTV 110 S		40496
4	1	PROFILE CTV 110	STROKE + 90	39731
5	2	RAIL GUIDE AR-HR 15	STROKE + 88	41518
6	1	BALL SCREW CTV 110	STROKE + 193	
		16 x 5 ISO7 - STANDARD, ISO5 - ON REQUEST		35452
		16 x 10 ISO7 - STANDARD, ISO5 - ON REQUEST		35462
		16 x 16 ISO7 - STANDARD, ISO5 - ON REQUEST		35463
7	1	PROFILE COVER CTV 110	STROKE + 90	39896
8	2	PROTECTION STRIP ANTISTATIC PU FOR CTV 110	2 x STROKE + 271	38930
	2	PROTECTION STRIP CORROSION RESISTANT CTV 110	2 x STROKE + 271	46082
9	2	COVER FOR BGR 30		-
10		ALLEN SCREW M4 x 14 DIN 912	(RAIL LENGTH/60+0,5) x 2	49492
11	1	ROUND END KEY 4 x 4 x 20 DIN 6885A		40778
12		COVER FOR AR-HR 15	(RAIL LENGTH/60+0,5) x 2	-
13	1	CONNECTION PLATE CTV 110 S		
		CONNECTION PLATE CTV 110 S KPL		48348
14		SQUARE NUT M4 DIN 562	(RAIL LENGTH/60+0,5) x 2	40682
15	1	BALL NUT RSY		
		16 x 5		39448
		16 x 10		39440
		16 X 16		39441
16	2	CARRIAGE BLOCK AR15MN S V1 N		45195

ASSEMBLY CTV 110 L

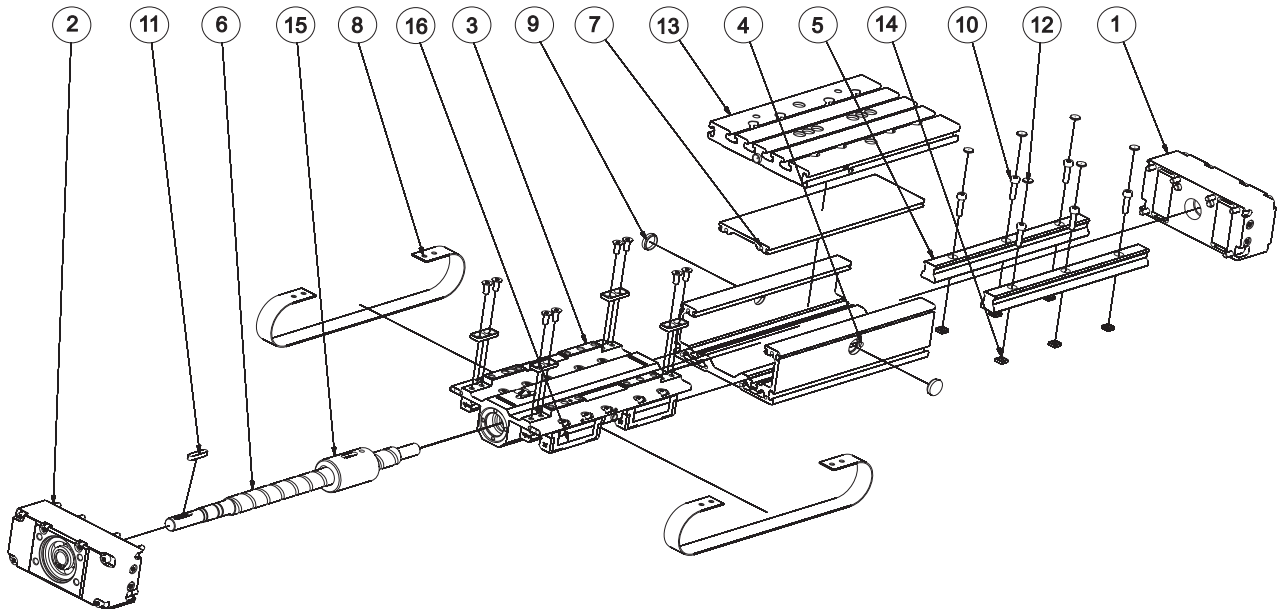

ITEM	QTY	PART NAME	LENGTH / QTY	ID
1	1	BACK BLOCK CTV 110		40492
2	1	FRONT BLOCK CTV 110		40489
3	1	CARRIAGE CTV 110 L		40503
4	1	PROFILE CTV 110	STROKE + 175	39731
5	2	RAIL GUIDE AR-HR 15	STROKE + 173	41518
6	1	BALL SCREW CTV 110	STROKE + 278	
		16 x 5 ISO7 - STANDARD, ISO5 - ON REQUEST		35452
		16 x 10 ISO7 - STANDARD, ISO5 - ON REQUEST		35462
		16 x 16 ISO7 - STANDARD, ISO5 - ON REQUEST		35463
7	1	PROFILE COVER CTV 110	STROKE + 175	39896
8	2	PROTECTION STRIP ANTISTATIC PU FOR CTV 110	2 x STROKE + 356	38930
	2	PROTECTION STRIP CORROSION RESISTANT CTV 110	2 x STROKE + 356	46082
9	2	COVER FOR BGR 30		-
10		ALLEN SCREW M4 x 14 DIN 912	(RAIL LENGTH/60+0,5) x 2	49492
11	1	ROUND END KEY 4 x 4 x 20 DIN 6885A		40778
12		COVER FOR AR-HR 15	(RAIL LENGTH/60+0,5) x 2	-
13	1	CONNECTION PLATE CTV 110 L		
		CONNECTION PLATE CTV 110 L KPL		48349
14		SQUARE NUT M4 DIN 562	(RAIL LENGTH/60+0,5) x 2	40682
15	1	BALL NUT RSY		
		16 x 5		39448
		16 x 10		39440
		16 X 16		39441
16	4	CARRIAGE BLOCK AR15MN S V1 N		45195

ASSEMBLY CTV 145 S

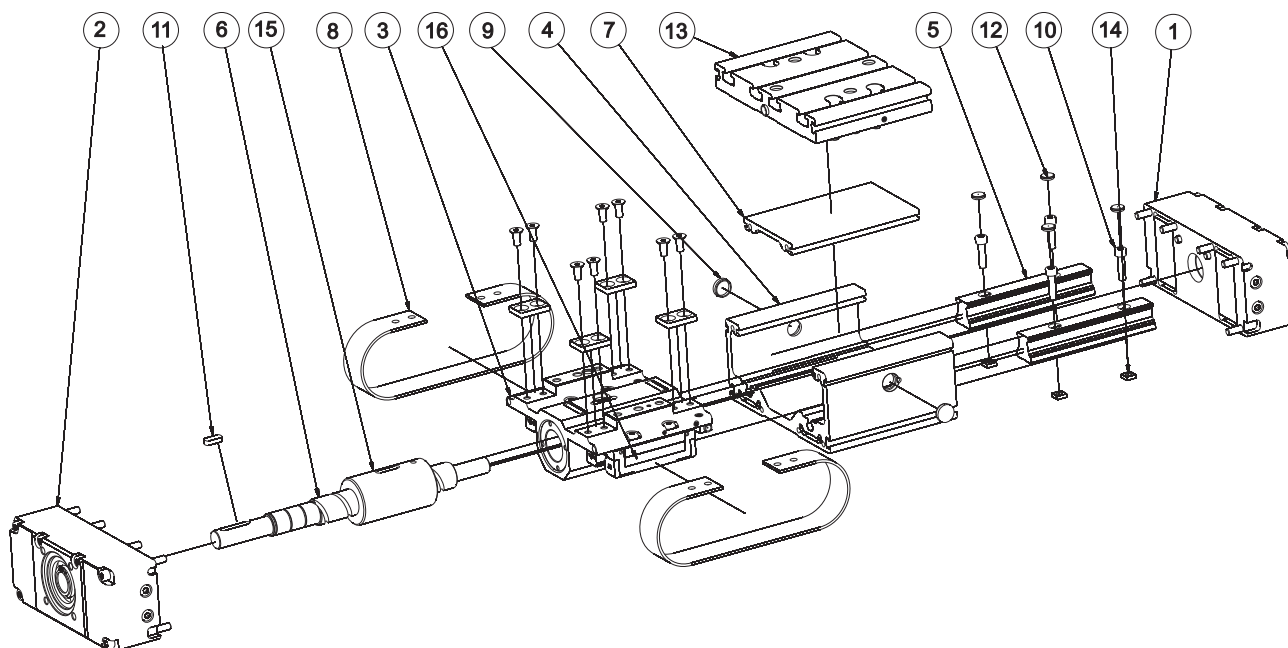

ITEM	QTY	PART NAME	LENGTH / QTY	ID
1	1	BACK BLOCK CTV 145		40508
2	1	FRONT BLOCK CTV 145		40507
3	1	CARRIAGE CTV 145 S		40509
4	1	PROFILE CTV 145	STROKE + 110	39733
5	2	RAIL GUIDE AR-HR 20	STROKE + 108	41515
6	1	BALL SCREW CTV 145	STROKE + 235	
		20 x 5 ISO7 - STANDARD, ISO5 - ON REQUEST		35453
		20 x 10 ISO7 - STANDARD, ISO5 - ON REQUEST		42091
		20 x 20 ISO7 - STANDARD, ISO5 - ON REQUEST		35464
7	1	PROFILE COVER CTV 145	STROKE + 110	39897
8	2	PROTECTION STRIP ANTISTATIC PU FOR CTV 145	2 x STROKE + 339	40551
	2	PROTECTION STRIP CORROSION RESISTANT CTV 145	2 x STROKE + 339	46080
9	2	COVER FOR BGR 30		-
10		ALLEN SCREW M5 x 20 DIN 912	(RAIL LENGTH/60+0,5) x 2	52936
11	1	ROUND END KEY 5 x 5 x 25 DIN 6885A		37038
12		COVER FOR AR-HR 20	(RAIL LENGTH/60+0,5) x 2	-
13	1	CONNECTION PLATE CTV 145 S		
		CONNECTION PLATE CTV 145 S KPL		48351
14		SQUARE NUT M5 DIN 562	(RAIL LENGTH/60+0,5) x 2	40768
15	1	BALL NUT RSY		
		20 x 5		39449
		20 x 10		39442
		20 X 20		39443
16	2	CARRIAGE BLOCK AR20MN S V1 N		45196

ASSEMBLY CTV 145 L

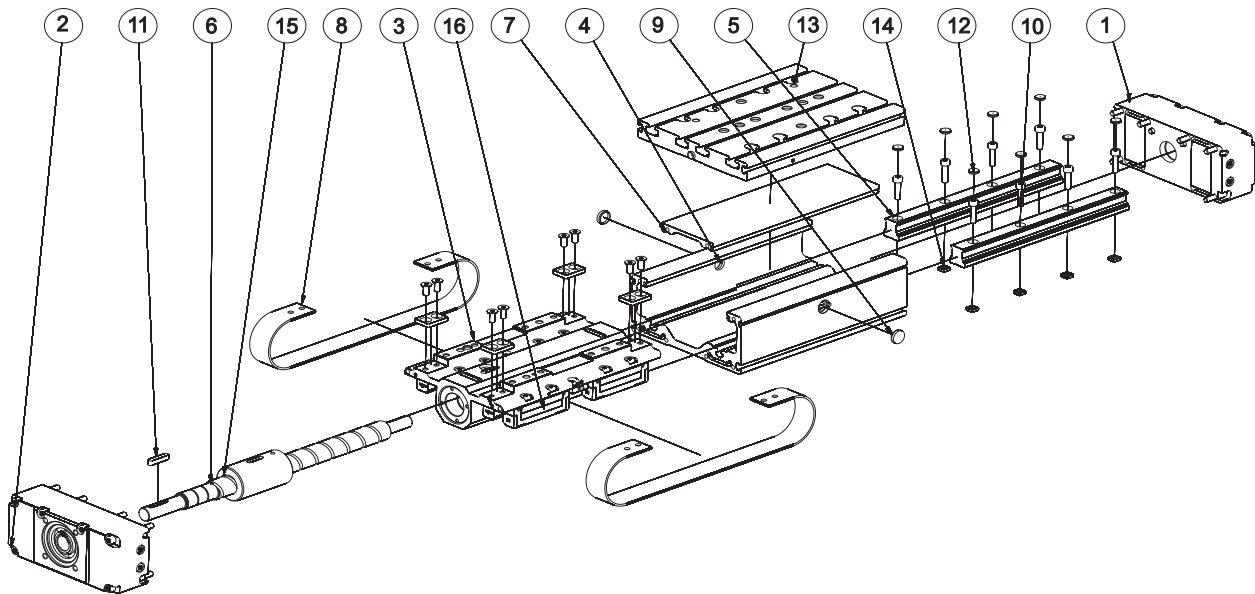

ITEM	QTY	PART NAME	LENGTH / QTY	ID
1	1	BACK BLOCK CTV 145		40508
2	1	FRONT BLOCK CTV 145		40507
3	1	CARRIAGE CTV 145 L		40510
4	1	PROFILE CTV 145	STROKE + 210	39733
5	2	RAIL GUIDE AR-HR 20	STROKE + 208	41515
6	1	BALL SCREW CTV 145	STROKE + 335	
		20 x 5 ISO7 - STANDARD, ISO5 - ON REQUEST		35453
		20 x 10 ISO7 - STANDARD, ISO5 - ON REQUEST		42091
		20 x 20 ISO7 - STANDARD, ISO5 - ON REQUEST		35464
7	1	PROFILE COVER CTV 145	STROKE + 210	39897
8	2	PROTECTION STRIP ANTISTATIC PU FOR CTV 145	2 x STROKE + 439	40551
	2	PROTECTION STRIP CORROSION RESISTANT CTV 145	2 x STROKE + 439	46080
9	2	COVER FOR BGR 30		-
10		ALLEN SCREW M5 x 20 DIN 912	(RAIL LENGTH/60+0,5) x 2	52936
11	1	ROUND END KEY 5 x 5 x 25 DIN 6885A		37038
12		COVER FOR AR-HR 20	(RAIL LENGTH/60+0,5) x 2	-
13	1	CONNECTION PLATE CTV 145 L		
		CONNECTION PLATE CTV 145 L KPL		48350
14		SQUARE NUT M5 DIN 562	(RAIL LENGTH/60+0,5) x 2	40768
15	1	BALL NUT RSY		
		20 x 5		39449
		20 x 10		39442
		20 X 20		39443
16	4	CARRIAGE BLOCK AR20MN S V1 N		45196

REPLACEMENT OF ASSEMBLIES - CTV SERIES



- any furthermentioned modifications, without our written consent, will void our liability in respect of the linear unit.
- before any operation make sure that the module is disconnected from the power grid to prevent possible injuries caused by the electrical current or moving parts.
- CTV 90: due to the precise fit between railguide MR 12 and carriage block Mini MR 12 both need to be replaced at the same time even if only one of them fails.

Replacing the floating bearing

STEP 1: if necessary remove the cover plate and shaft key (page 1.035.0).

STEP 2: unscrew the six screws that attach frontal end block to the main profile and the leading profile.

STEP 3: remove the two screws (one on CTV90) that hold each protection strip at the front end of the carriage. Remove the two locking set screws on the bottom of the frontal end block and save the rubber cylinders (reuse them in step 7).

STEP 4: slide the frontal end block off the bearing with the protection strips still in the end block. If the spindle is longer support it with plastic blocks.

 **STEP 5:** remove the bearings on the frontal end of spindle (remove the circlips and the bearings with appropriate tools).

 **STEP 6:** put the new bearings on the spindle and secure them with circlips. The bearings must not be pushed by the outer ring.

STEP 7: slide the frontal end block back in place. Check that the protection strip lies in the grooves in profiles. The frontal end block must lie parallel to profile. Secure the frontal end block with glued screws (Loctite 243); before tightening the screws slide the carriage as close to the frontal end block as possible.

Note: it may be difficult to put the protection strip back through the end block - help yourself with a piece of wire or curved thin metal strip.

 **STEP 8:** install the locking set screws in the bottom of the frontal end block. Tighten them with torque of 1Nm and then unscrew them for 1 of a turn (for CTV 90 unscrew for 3/4 of a turn).

STEP 9: attach the protection strips back to the carriage and glue the screws.

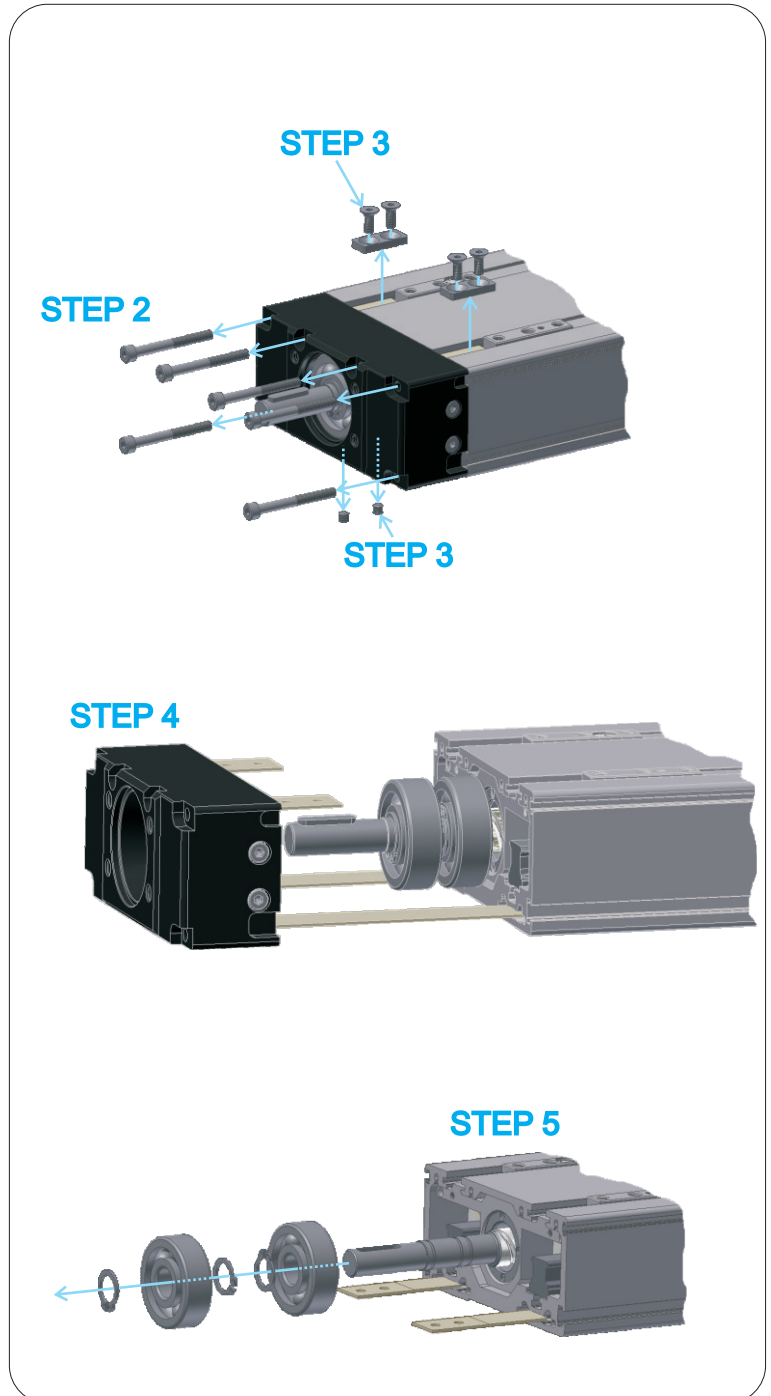

Note: all the screws (except the set screws) must be glued (Loctite 243) and screwed with the torque specified in the table on page 1.005.0 unless written otherwise at the individual steps.

Removing the spindle and ball nut from the module

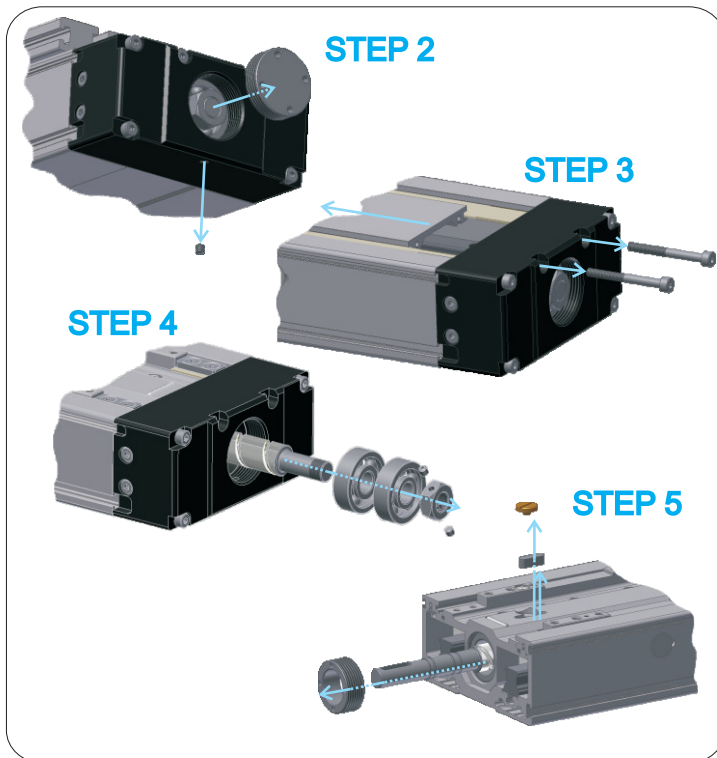

STEP 1: remove the floating bearing as described in "Replacing the floating bearing".

STEP 2: Remove the set screw (in the bottom of the rear end block) and the bearing cover (remove the bearing cover with the appropriate tools).

STEP 3: remove the leading profile by unscrewing the middle two screws on the rear end block.

STEP 4: push the carriage towards the rear end block so that the fixed bearing comes out of the rear end block. Remove the fixed bearing from spindle as described in „Replacing the fixed bearing“. You can remove carriage from profile for easier manipulation. Make sure that balls do not fall from rail-guide blocks.

STEP 5: heat carriage nut with hot air until glue liquefies and unscrew it from the carriage. Remove the blue seal, unscrew brass screw and remove nut key (insert the screw into the key and pull it out).

STEP 6: remove the spindle with the ball nut from the module by taking it out from the front (do not unscrew the nut from the spindle!).

Replacing the fixed bearing

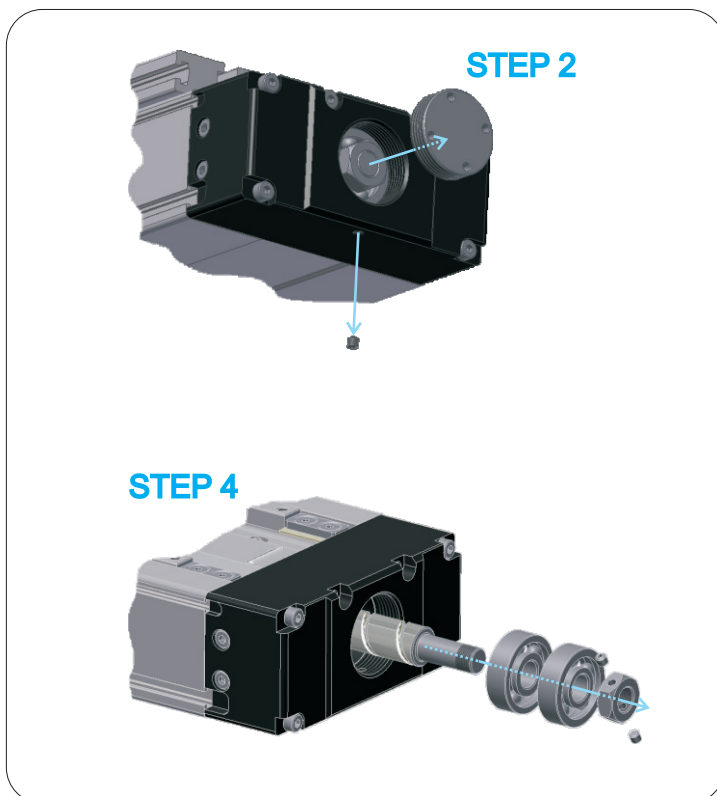

STEP 1: slide the carriage as close as possible to the frontal end block and remove the two set screws in the bottom of the frontal end block, save the rubber cylinders and reuse it in step 6.

STEP 2: remove the bearing cover from the rear end block (remove it with appropriate tools) and save the brass cylinder, reuse it in step 6.

STEP 3: slide the carriage towards the rear end block together with spindle so that the fixed bearing comes out of the rear end block.

STEP 4: remove the fixed bearing. Save the spacing ring that lies between the two separate bearings and aluminum discs under the set screws in the nut.

STEP 5: mount the new fixed bearing. Insert the spacing ring between the two bearings and make sure that the bearings are turned correctly. Tighten nut only as much so that you can not turn bearing in opposite directions by hand. Insert back aluminium discs and set screws into the nut. Total runout of the bearing must not exceed 0.01 mm.

STEP 6: assemble the module back together by:

- sliding the carriage towards the frontal end block,
- inserting the fixed bearing cover,
- inserting the two set screws that were removed from frontal end block and one from the rear end block.

Note: all the screws (except the set screws) must be glued (Loctite 243) and screwed with the torque specified in the table on page 1.005.0 unless written otherwise at the individual steps.

Replacing the spindle, ball nut and/or the carriage

Note: the spindle and ball nut must be replaced at the same time as each nut is paired with a specific spindle. This way we can guarantee a smooth operation.

STEP 1: remove the spindle and ball nut from the module as described in the previous chapters.

STEP 2: slide the carriage from the module and replace it with the new one. Turn carriage so that the magnets are closer to the frontal end block. Take care that the balls do not fall out of the rail-guide blocks (if you are not replacing the carriage ignore this step).

STEP 3: insert the spindle with the nut into the module and secure ball nut to the carriage with key and screw (do not remove the ball nut from the spindle).

STEP 4: put glue (Loctite 243) on the outermost two threads of the carriage nut and screw it into the carriage. Tighten it with appropriate torque.

CTV 90 - 4 Nm
CTV 110 - 13 Nm
CTV 145 - 23 Nm

 **STEP 5:** mount the fixed bearing to the spindle as described in "Replacing the fixed bearing".

 **STEP 6:** mount the leading profile and the floating bearing as described in "Replacing the floating bearing".

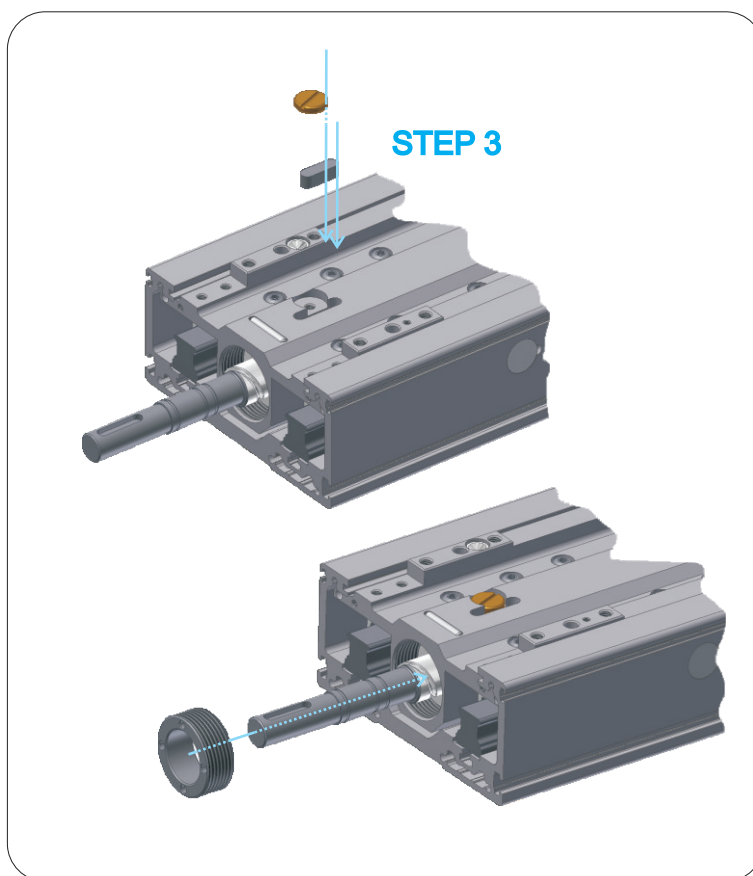

Note: all the screws (except the set screws) must be glued (Loctite 243) and screwed with the torque specified in the table on page 1.005.0 unless written otherwise at the individual steps.

Replacing the rails

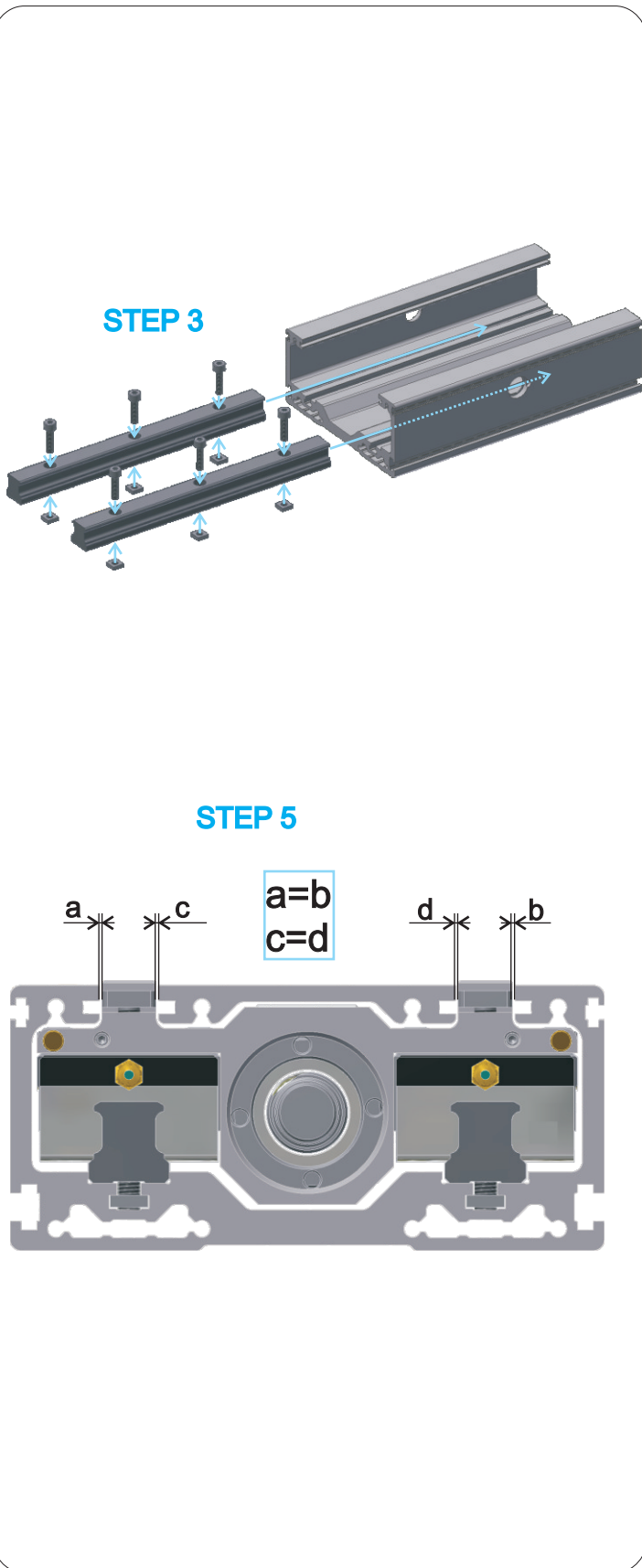

Note: if the rail guides are damaged it is very likely that the rail guide blocks are damaged too. If you replace the rails it is best that you also replace the carriage.

We recommend that in this case you should send us complete module as this is the only way that we can ensure sufficient quality.

STEP 1: remove both end blocks, the spindle and the carriage from the main profile.

STEP 2: remove the rails from the profile.

STEP 3: attach the screws and nuts to the new rails and put them into the profile - do not tighten or glue the screws (for CTV90 screws are screwed directly into the profile so the screws must be glued).

STEP 3 CTV 90: glue and insert the screws in the rails, insert the rails in the profile.

STEP 4: slide the carriage on the rails.

STEP 5: tighten the screws on the rail which lies tightly in the groove. Slide the carriage to one end of the profile and tighten screw nearest to carriage on the other rail. Slide carriage to the other side and tighten one screw there. If the module is longer tighten a few more screws the same way. After the rail is centered with a few screws tighten all the screws with the specified torque.

NOTE: for CTV 110 and ctv 145 tighten th screws from STEP 5 according to lower table.

size	M3	M4	M5	M6	M8
T [Nm]	0.9	1.9	3.4	6.0	12.5

STEP 6: insert plastic plugs over the screws (if necessary remove the carriage from the rails)

STEP 7: insert the spindle with the ball nut into the module from the front and secure the spindle nut to the carriage with the key and screw (do not remove nut from the spindle!)

STEP 8: mount the fixed bearing to the spindle as described in "Replacing the fixed bearing".

STEP 9: mount the leading profile and the floating bearing as described in replacing the floating bearing.

STEP 10: finish by mounting the frontal end block. Align it with the profile of the module before tightening the screws. Secure the floating bearing with the set screw in the bottom of the frontal end block.

Note (CTV 90): Due to the precise fit between railguide MR 12 and carriage block Mini MR 12 both need to be replaced at the same time even if only one of them fails.

Note: all the screws (except the set screws) must be glued (Loctite 243) and screwed with the torque specified in the table on page 1.005.0 unless written otherwise at the individual steps.

Replacing the protection strip

STEP 1: slide the carriage to the middle of the profile.

STEP 2: remove the screws that are holding the protection strip.

STEP 3: remove the set screws in the bottom of the end blocks and save the cylinders and reuse them in step 9. Remove the attachment screws of the frontal end block and the leading profile.

STEP 4: remove the frontal end block and the leading profile.

STEP 5: remove the protection strips

STEP 6: insert the new protection strips into the hole in the rear end block and push them through the profile. Attach them to the rear end of the carriage.

STEP 7: insert the leading profile and attach it to the rear end block.

STEP 8: slide the protection strips through the frontal end block. Insert it in the groove between the leading profile and the main profile. Attach them to the carriage while moving the frontal end block closer to the main profile.

STEP 9: set the frontal end block to the middle of the main profile and the leading profile to the middle of the carriage. Tighten the screws. Reinstall the set screws in the bottom of the end blocks.

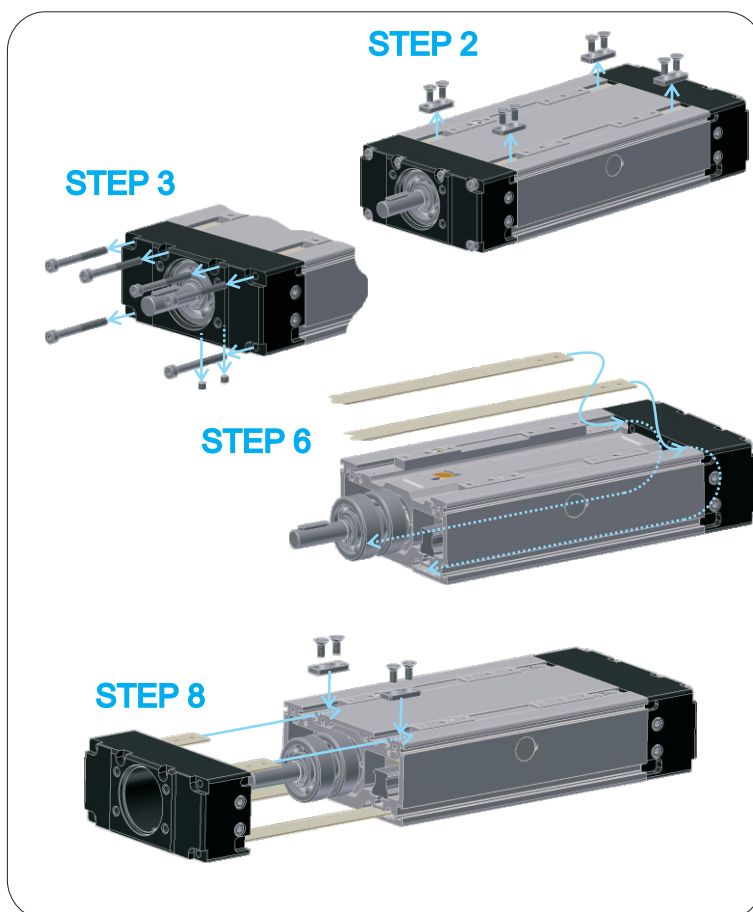

Note: all the screws (except the set screws) must be glued (Loctite 243) and screwed with the torque specified in the table on page 1.005.0 unless written otherwise at the individual steps.